

**KD225 - KD315 - KD350  
KD400 - KD440**

**WORKSHOP MANUAL**



 **rehlko**



### REGISTRATION OF MODIFICATIONS TO THE DOCUMENT

Any modifications to this document must be registered by the drafting body, by completing the following table.

Drafting body Ente compilatore Organisme rédacteur Austeller Entidad redactora Entidade compiladora	Document code Codice documento Code document Buchcode Cod. libro Cód. di libro	Revision Revisione Révision Vertatung Revisión Revisão	Issue date Data emissione Date d'émission Ausgabe-datum Fecha edición Data emissão	Review date Data revisione Date révision Vertatungs-datum Fecha revisión Data revisão	Edited by Redatto da Rédigé par Bearbeitet von Editado por Editado por	Endorsed Visto Vu Verm. Aprobación Assinatura
Technical Documentation	ED0053029330	01	09 / 2019	03 / 2026	M. Silvestrone	SERVICE DEPT.

Translated from the original manual in Italian language.

Data reported in this issue can be modified at any time by REHLKO.



**KD225**  
**KD315**  
**KD350**  
**KD400**  
**KD440**

## PREFACE

- Every attempt has been made to present within this service manual, accurate and up to date technical information.  
However, development on the **REHLKO** series is continuous.  
Therefore, the information within this manual is subject to change without notice and without obligation.
- The information contained within this service manual is the sole property of **REHLKO**.  
As such, no reproduction or replication in whole or part is allowed without the express written permission of **REHLKO**.

Information presented within this manual assumes the following:

- 1 - The person or people performing service work on **REHLKO** series engines is properly trained and equipped to safely and professionally perform the subject operation;
  - 2 - The person or people performing service work on **REHLKO** series engines possesses adequate hand and **REHLKO** special tools to safely and professionally perform the subject service operation;
  - 3 - The person or people performing service work on **REHLKO** series engines has read the pertinent information regarding the subject service operations and fully understands the operation at hand.
- This manual was written by the manufacturer to provide technical and operating information to authorised **REHLKO** after-sales service centres to carry out assembly, disassembly, overhauling, replacement and tuning operations.
  - As well as employing good operating techniques and observing the right timing for operations, operators must read the information very carefully and comply with it scrupulously.
  - Time spent reading this information will help to prevent health and safety risks and financial damage.  
Written information is accompanied by illustrations in order to facilitate your understanding of every step of the operating phases.

**LIMITED 3 YEAR REHLKO® DIESEL ENGINE WARRANTY**

Consult the web page <https://www.engines.rehiko.com/warranty> and select Diesel Engines.

**CALIFORNIA EMISSION CONTROL WARRANTY STATEMENT  
YOUR WARRANTY RIGHTS AND OBLIGATIONS**

The California Air Resources Board and Rehiko are pleased to explain the **emission control system warranty** on your 2012 engine. In California, new heavy-duty off-road engines must be designed, built and equipped to meet the State's stringent anti-smog standards. Rehiko must warrant the emission control system on your engine for the time period listed below provided there has been no abuse, neglect or improper maintenance of your engine.

Your emission control system may include parts such as the fuel-injection system and the air induction system. Also included may be hoses, connectors and other emission related assemblies.

Where a warrantable condition exists, Rehiko will repair your heavy-duty off-road engine at no cost to you including diagnosis, parts and labor.

**MANUFACTURER'S WARRANTY COVERAGE:**

Your off-road, diesel engine emission control system is covered under warranty for a period of five (5) years or 3,000 hours, whichever occurs first, beginning on the date the engine or equipment is delivered to an ultimate purchaser for all constant speed engines with maximum power  $19 \leq kW < 37$  and rated speed less than 3,000 rpm, all variable speed engines with maximum power  $19 \leq kW < 37$ , and all variable or constant speed engines with maximum power greater than 37 kW. Your off-road, diesel engine emission control system on variable or constant-speed engines with maximum power less than 19 kW, and for constant speed engines with maximum power  $19 \leq kW < 37$  and rated speed equal to or greater than 3,000 rpm is covered under warranty for a period of two (2) years or 1,500 hours, whichever occurs first. If any emission related part on your engine is defective, the part will be repaired or replaced by Rehiko

**OWNER'S WARRANTY RESPONSIBILITIES:**

As the heavy-duty off-road engine owner, you are responsible for the performance of the **required maintenance listed in your Rehiko owner's manual**. Rehiko recommends that you retain all receipts covering maintenance on your heavy-duty off-road engine, but Rehiko cannot deny warranty solely for the lack of receipts or for your failure to ensure the performance of all recommended scheduled maintenance.

As the heavy-duty off-road engine owner, you should however be aware that Rehiko may deny you warranty coverage if your heavy-duty off-road engine or emission control related component has failed due to abuse, neglect, improper maintenance or unapproved modifications.

Your engine is designed to operate on commercial diesel fuel (No. 1 or No. 2 low sulfur or ultra low sulfur diesel fuel) only. Use of any other fuel may result in your engine no longer operating in compliance with California's emissions requirements.

You are responsible for initiating the warranty process. The Air Resources Board suggests that you present your heavy-duty off-road engine to a Rehiko dealer as soon as a problem exists. The warranty repairs should be completed by the dealer as expeditiously as possible.

Please review the document titled, "Rehiko Federal and California Emission Control Systems Limited Warranty Off-Road Diesel Engines", for complete details of your heavy-duty off-road engine warranty. If you have any questions regarding your warranty rights and responsibilities or the location of the nearest Rehiko authorized service location, you should contact Rehiko at 1-800-544-2444 or access our website at <https://www.engines.rehiko.com/warranty>.

This manual contains pertinent information regarding the repair of REHLKO water-cooled, indirect injection Diesel engines type **KD 225-315-350-400-440**: updated March, 2026.

## INDEX

<b>PREFACE</b> .....	<b>2</b>
<b>WARRANTY CERTIFICATE</b> .....	<b>3</b>
Limited 3 year Rehlko® diesel engine warranty .....	3
California emission control warranty statement .....	3
Your warranty rights and obligations .....	3
<b>1 - TROUBLE SHOOTING</b> .....	<b>7</b>
Possible causes and trouble shooting.....	7
<b>2 - GENERAL REMARKS AND SAFETY INFORMATION</b> .....	<b>8</b>
Safety regulations .....	8
General safety during operating phases .....	9
Safety and environmental impact .....	9
<b>3 - MODEL NUMBER AND IDENTIFICATION</b> .....	<b>11</b>
Manufacturer and motor identification data .....	11
Approval data.....	11
<b>4 - TECHNICAL DATA</b> .....	<b>12</b>
Characteristics kd 225_315_350.....	12
Characteristics kd 400_440.....	13
<b>5 - CHARACTERISTICS</b> .....	<b>14</b>
Characteristics power, torque and specific fuel consumption curves .....	14
<b>6 - OVERALL DIMENSIONS</b> .....	<b>16</b>
<b>7 - MAINTENANCE - RECOMMENDED OIL TYPE - REFILLING</b> .....	<b>18</b>
Maintenance .....	18
Fuel .....	18
Recommended oil.....	19
Acea sequences .....	19
<b>8 - DISASSEMBLY/REASSEMBLY</b> .....	<b>20</b>
Disassembly and reassembly.....	20
Dry air cleaner for kd 315 and kd 350.....	20
Dry air cleaner for kd 225 .....	20
Dry air cleaner for kd 400-440 .....	21
Prefilter for dry air filter .....	21
Oil-bath air cleaner (optional) .....	22
Muffler .....	22
Rocker arm cover breather system.....	22
Rocker arm cover - breather ricirculation .....	23
Valve/rocker arm clearance (KD 225-315-350).....	23
The engines KD 400 and 440 have hydraulic tappets, therefore no adjustment is required .....	23
Do not start the engine for approximately 4 hours to allow the hydraulic tappets to settle completely .....	23
Hydraulic tappets KD 400-440 .....	24
Tank .....	25
Fuel filter KD 225-400-440 (version with internal filter) .....	25
Fuel filter for KD 225 - 315 - 350 - 400 - 440 (version with external filter).....	25
Re-coil starting.....	26
Shroud .....	26
Flywheel.....	26

Cylinder head.....	27
Injector projection.....	27
Valves - Disassembly.....	28
Valves - Oil seal in valve guide.....	28
Valve, springs.....	28
Valves, characteristics.....	29
Valves, guides and housings.....	29
Valves, guide insertion.....	29
Dimensions and clearance between guides and valve stems (mm).....	30
Valves seats and valve seat bores.....	30
Valve seat lapping.....	30
Cylinder.....	31
Cylinder roughness.....	31
Piston.....	31
Dimensions of pistons and cylinders, Logo.....	31
Piston rings, distance between the tips (mm).....	33
Piston rings, play between the slots (mm).....	34
Piston rings, assembly order.....	34
Piston - Refitting.....	34
Clearance.....	34
Piston protrusion check.....	35
Connecting rod.....	36
Connecting rod, piston pin.....	36
Connecting rod alignment.....	36
Crankshaft end play.....	36
Drive shaft oil seals.....	37
Drive shaft, lubrication ducts, bore thread on flywheel side and p.t.o.....	37
Drive shaft, connection radius.....	37
Drive shaft, main journal/crankpin diameter, gear cover bearing inside diameter on timing side.....	37
Crankshaft - journal diameter (mm).....	38
Availability of bearings.....	38
Camshaft.....	39
Camshaft journals and bore.....	39
Dimensions of camshaft journals and bore (mm).....	39
Cam height (mm).....	39
Camshaft timing.....	40
Camshaft – Antireverse system KD 400-440.....	40
Automatic decompression.....	41
Camshaft end play.....	41
Dynamic balancer (on request).....	41
Dinamic balancer timing.....	43
Valve timing check.....	43
Timing angles for operation (0.15 valve play).....	44
Timing angles for inspection (0.65-0.70 valve play).....	44
Speed governor.....	45
Speed governor removal.....	45
Refitting gear cover on timing side.....	45

<b>9 - LUBRICATION SYSTEM.....</b>	<b>46</b>
KD 225 - 315 - 350 lubrication system and breather recirculation system.....	46
KD 400-440 lubrication system and breather recirculation system.....	47
Oil pump.....	48
Oil pump - clearance between rotors.....	48
Oil pressure regulation valve.....	48
Internal strainer.....	48
Oil filter.....	49
Oil pressure check.....	49
Calibrated pipe for lubrication of hydraulic tappets.....	49
Oil pressure curve at idle speed.....	50
Oil pressure curve at full speed.....	50
Fuelling/injection circuit for KD 315-350-400-440.....	51
Fuelling/injection circuit for KD 225.....	51

<b>10 - FUEL SYSTEM.....</b>	<b>52</b>
Fuel filter KD 225-315-350-400-440 .....	52
Fuel filter KD 225 (version with internal filter in tank) .....	52
Feed pump (optional).....	52
Fuel pump, drive rod protrusion.....	53
Injection pump .....	53
Injection pump fitting in the crankcase .....	53
Injection pump components and disassembly .....	54
Injection pump, body, plunger and delivery valve.....	54
Injection pump refitting .....	54
Injection pump non-return valve .....	55
Outlet fitting components for 315-350 EPA E 400-440 engines .....	55
Injection pump, Rilsan tube removal .....	55
Injection pump, Rilsan tube refitting .....	55
Injection pump delivery check on test bench .....	56
Static injection timing.....	56
Static injection lead test on flywheel.....	57
Injection advance adjustment.....	58
Injector .....	58
Leakage time (waste).....	59
Nozzles .....	59
Injector calibration .....	59
<b>11 - ELECTRICAL SYSTEM.....</b>	<b>62</b>
12V, 12A electric ignition diagram .....	61
Alternator .....	61
Alternator battery charger graph (12V, 12A).....	61
24V, 9A alternator battery recharging curve.....	62
12V, 30A alternator battery recharging curve.....	62
Voltage regulator.....	62
12V electric starter diagram with voltage regulator built into the ignition panel.....	63
12V electric ignition layout with motor protection (optional) .....	63
Diagram of electric starter motor protection with sole self-winding starter - without battery - (optional).....	64
Testing voltage regulator for proper operation .....	65
Starting motor .....	65
Characteristic curves for starting motor type DW (L) 12V, 1.1 KW.....	65
Characteristic curves of Bosch starter motor type DW (L) 12V, 0.9 kW.....	66
Characteristic curves of Bosch starter motor type DW (L) 24V, 1.6 kW.....	66
Ignition switch positions.....	66
Adjustments - KD 315-350.....	67
Idling speed setting in no-load conditions (standard).....	67
Idle speed adjustment, for small car versions .....	67
Full speed setting in no-load conditions (standard).....	67
<b>12 - SETTINGS / ADJUSTMENTS .....</b>	<b>68</b>
Adjustments - KD 225-400-440 .....	68
No-load idling adjustment (standard).....	68
No-load top rate adjustment (standard).....	68
Injection pump flow rate adjustment For KD 225-315-350-400-440 .....	68
Injection pump delivery limiting and torque adapter (standard) .....	68
Injection pump delivery setting .....	69
Required settings (the most common ones).....	69
<b>14 - STORAGE.....</b>	<b>70</b>
Storage .....	70
Internal engine protection: .....	70
Injection systems protection: .....	70
External engine protection:.....	70
Procedures to be carried out before start the engine.....	71
<b>15 - TORQUE SPECIFICATIONS .....</b>	<b>72</b>
Main torque specifications .....	72
Use of sealant .....	72
Table of tightening torques for standard screws (coarse thread).....	73
Table of tightening torques for standard screws (fine thread) .....	73

**POSSIBLE CAUSES AND TROUBLE SHOOTING**
**THE ENGINE MUST BE STOPPED IMMEDIATELY WHEN:**

- 1) - The engine rpms suddenly increase and decrease
- 2) - A sudden and unusual noise is heard
- 3) - The colour of the exhaust fumes suddenly darkens
- 4) - The oil pressure indicator light turns on while running.

**TABLE OF LIKELY ANOMALIES AND THEIR SYMPTOMS**

The following table contains the possible causes of some failures which may occur during operation. Always perform these simple checks before removing or replacing any part.

POSSIBLE CAUSE		TROUBLE									
		Engine does not start	Engine starts but stops	No acceleration	Non-uniform speed	Black smoke	White smoke	Too low oil pressure	Increase oil level	Excessive oil consumption	oil and fuel dripping from exhaust
FUEL CIRCUIT	Clogged pipes										
	Clogged fuel filter										
	Air inside fuel circuit										
	Clogged tank breather hole										
	Faulty fuel pump										
	Injector jammed										
	Jammed injection pump delivery valve										
	Wrong injector setting										
	Excessive plunger blow-by										
	Jammed injection pump delivery control										
	Wrong injection pump setting										
LUBRICATION	Oil level too high										
	Jammed pressure relief valve										
	Worn oil pump										
	Air inside oil suction pipe										
	Faulty pressure gauge or switch										
	Clogged oil suction pipe										
MAINTENANCE	Battery discharged										
	Wrong or inefficient cable connection										
	Defective ignition switch										
	Defective starter motor										
SETTINGS/REPAIRS	Clogged air filter										
	Excessive idle operation										
	Incomplete running-in										
	Engine overloaded										
	Advanced injection										
	Delayed injection										
	Incorrect governor linkage adjustment										
	Broken or loose governor spring										
	Idle speed too low										
	Worn or jammed piston rings										
	Worn or scored cylinders										
	Worn valve guides										
	Jammed valves										
	Worn bearings										
Governor linkage not free to slide											
Drive shaft not free to slide											
Damaged cylinder head gasket											

## SAFETY REGULATIONS

### GENERAL NOTES

- Rehiko engines are built to provide safe and longlasting performances, but in order to obtain these results it is essential that the maintenance requirements described in the manual are observed along with the following safety recommendations.
- The engine has been built to the specifications of a machine manufacturer, and it is his responsibility to ensure that all necessary action is taken to meet the essential and legally prescribed health and safety requirements. Any use of the machine other than that described cannot be considered as complying with its intended purpose as specified by Rehiko, which therefore declines all responsibility for accidents caused by such operations.
- The following instructions are intended for the user of the machine in order to reduce or eliminate risks, especially those concerning the operation and standard maintenance of the engine.
- The user should read these instructions carefully and get to know the operations described. By not doing so he may place at risk his own health and safety and that of anyone else in the vicinity of the machine.
- The engine may be used or mounted on a machine only by personnel suitably trained in its operation and aware of the dangers involved. This is particularly true for standard and, above all, special maintenance work. For special maintenance contact personnel trained specifically by Rehiko. This work should be carried out in accordance with existing literature.
- Rehiko declines all responsibility for accidents or for failure to comply with the requirements of law if changes are made to the engine's functional parameters or to the fuel flow rate adjustments and speed of rotation, if seals are removed, or if parts not described in the operating and maintenance manual are removed and reassembled by unauthorized personnel.

### WARNING

- In addition to all other machine specifications, ensure that the engine is in a near horizontal position when starting. If starting manually, ensure that the necessary operations can be performed without any risk of striking against walls or dangerous objects. Rope starting (except for recoil rope starting) is not permitted even in emergencies.
- Check that the machine is stable so that there is no risk of it overturning.
- Get to know the engine speed adjustment and machine stop operations.
- Do not start the machine in closed or poorly ventilated environments. The internal combustion process generates carbon monoxide, an odourless and highly toxic gas, so spending too long a time in an environment where the engine discharges its exhaust products freely can lead to loss of consciousness and even death.
- The engine may not be used in environments containing flammable materials, explosive atmospheres or easily combustible powders, unless adequate and specific precautions have been taken and are clearly stated and certified for the machine.
- To prevent the risk of fire, keep the machine at a distance of at least one metre from buildings or other machines.

- Children and animals must be kept at a sufficient distance from the machine to prevent any danger resulting from its operation.
- Fuel is flammable, so the tank must be filled only when the engine is turned off. Dry carefully any fuel that may have spilled, remove the fuel container and any cloths soaked in fuel or oil, check that any sound-absorbing panels made of porous material are not soaked with fuel or oil, and make sure that the ground on which the machine is located has not absorbed fuel or oil.
- Before starting, remove any tools that have been used for carrying out maintenance work to the engine and/or the machine and check that any guards removed have been replaced. In cold climates it is possible to mix kerosene with the diesel fuel to make the engine easier to start. The liquids must be mixed in the tank by pouring in first the kerosene and then the diesel fuel. Consult Rehiko technical office for mixture proportions. Petrol may not be used because of the risk of it forming flammable vapours.
- During operation the surface of the engine reaches temperatures that may be dangerous. Avoid in particular all contact with the exhaust system.
- The liquid cooling circuit is under pressure. Do not carry out any checks before the engine has cooled down, and even then open the radiator cap or the expansion tank cautiously. Wear protective clothing and glasses. If there is an electric fan, do not approach the engine while it is still hot as the fan may come on even when the engine is not running. Clean the cooling system with the engine turned off.
- While cleaning the oil bath air filter, check that the oil is disposed of in such a way as not to harm the environment. Any filtering sponges in the oil bath air filter should not be soaked with oil. The cyclone pre-filter cup must not be filled with oil.
- Since the oil must be emptied out while the engine is still hot (approx. 80°C), particular care should be taken in order to avoid burns. In any case make sure that oil does not come into contact with your skin because of the health hazards involved.
- Fuel vapours are highly toxic, so fill up only in the open air or in well ventilated environments.
- During operations which involve access to moving parts of the engine and/or removal of the rotary guards, disconnect and insulate the positive cable of the battery so as to prevent accidental short circuits and activation of the starter motor.
- Check the belt tension only when the engine is turned off.

### IMPORTANT

- To start the engine follow the specific instructions provided in the engine and/or machine operating manual. Do not use auxiliary starting devices not originally installed on the machine (e.g. Startpilot systems which utilise ether etc.)
- Before carrying out any work on the engine, turn it off and allow it to cool down. Do not perform any operation while the engine is running.
- Check that the discharged oil, the oil filter and the oil contained in the oil filter are disposed of in such a way as not to harm the environment.
- Close the fuel tank filler cap carefully after each filling operation. Do not fill the tank right up to the top, but leave sufficient space to allow for any expansion of the fuel.
- Do not smoke or use naked flames while filling.

- . Take care when removing the oil filter as it may be hot.
- . The operations of checking, filling up and replacing the cooling liquid must be carried out with the engine turned off and cold. Take particular care if liquids containing nitrites are mixed with others not containing these compounds as this may give rise to the formation of nitrosamines which are a health hazard. The cooling liquid is polluting, so dispose of in a manner that does not damage the environment.
- . In order to move the engine simultaneously use the eyebolts fitted for this purpose by **Rehiko**. These lifting points are however not suitable for the entire machine, so in this case use the eyebolts fitted by the manufacturer.

## GENERAL SAFETY DURING OPERATING PHASES

- The procedures contained in this manual have been tested and selected by the manufacturer's technical experts, and hence are to be recognised as authorised operating methods.
- A number of procedures must be carried out with the aid of equipment and tools that simplify and improve the timing of operations.
- All tools must be in good working condition so that engine components are not damaged and that operations are carried out properly and safely.
- It is important to wear the personal safety devices prescribed by work safety laws and also by the standards of this manual.
- Holes must be lined up methodically and with the aid of suitable equipment. Do not use your fingers to carry out this operation to avoid the risk of amputation.
- Some phases may require the assistance of more than one operator. If so, it is important to inform and train them regarding the type of activity they will be performing in order to prevent risks to the health and safety of all persons involved.
- Do not use flammable liquids (petrol, diesel, etc.) to degrease or wash components. Use special products.
- Use the oils and greases recommended by the manufacturer.  
Do not mix different brands or combine oils with different characteristics.
- Discontinue use of the engine if any irregularities arise, particularly in the case of unusual vibrations.
- Do not tamper with any devices to alter the level of performance guaranteed by the manufacturer.

## SAFETY AND ENVIRONMENTAL IMPACT

Every organisation has a duty to implement procedures to identify, assess and monitor the influence of its own activities (products, services, etc.) on the environment.

Procedures for identifying the extent of the impact on the environment must consider the following factors:

- Liquid waste
- Waste management
- Soil contamination
- Atmospheric emissions
- Use of raw materials and natural resources
- Regulations and directives regarding environmental impact

In order to minimise the impact on the environment, the manu-

facturer now provides a number of indications to be followed by all persons handling the engine, for any reason, during its expected lifetime.

- All packaging components must be disposed of in accordance with the laws of the country in which disposal is taking place.
- Keep the fuel and engine control systems and the exhaust pipes in efficient working order to limit environmental and noise pollution.
- When discontinuing use of the engine, select all components according to their chemical characteristics and dispose of them separately.

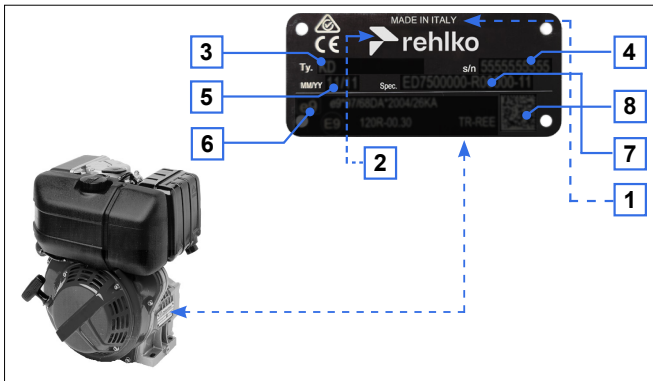

**MANUFACTURER AND MOTOR IDENTIFICATION DATA**

The identification plate shown in the figure can be found directly on the engine. It contains the following information:

- 1) Production place
- 2) Manufacturer identification
- 3) Engine model
- 4) Engine serial number
- 5) Month and year of production
- 6) Approval data
- 7) Engine version
- 8) Data matrix

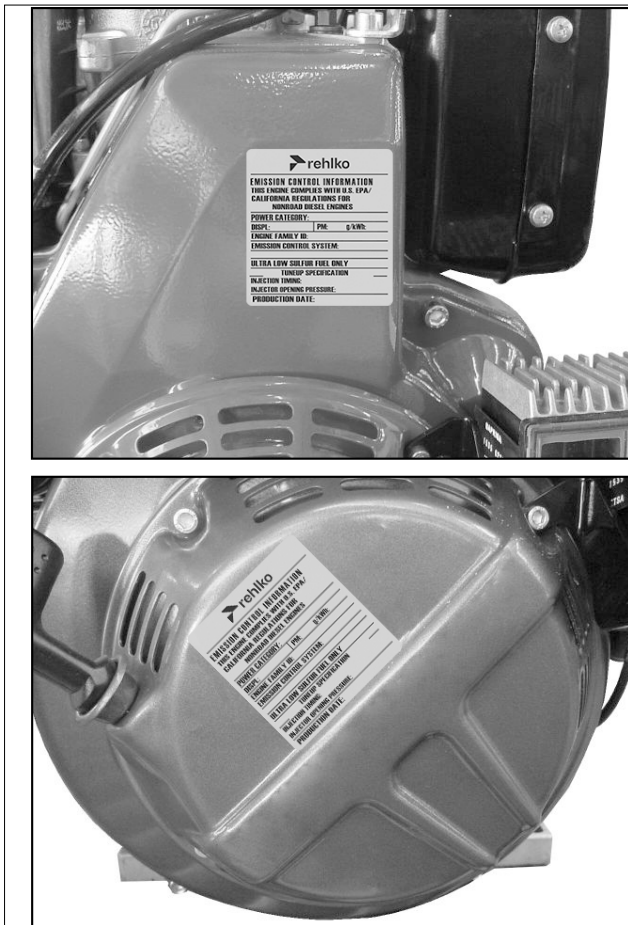
**Approval data**

The approval reference directives EC are on the engine plate.

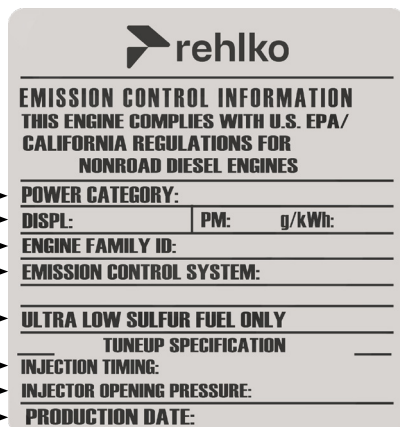

- 1) Model year
- 2) Power category, kW
- 3) Engine displacement
- 4) Particulate emission limit (g/kWh)
- 5) Engine family ID - N°
- 6) Emission Control System = ECS
- 7) Fuel with low sulphur content
- 8) Injection timing (BTDC)
- 9) Injector opening pressure (bar)

CHARACTERISTICS KD 225\_315\_350

ENGINE TYPE		225	315	350
Number of cylinders	N.	1	1	1
Bore	mm	69	78	82
Stroke	mm	60	66	66
Swept volume	Cm <sup>3</sup>	224	315	349
Compression ratio		21:1	20,3:1	20,3:1
R.P.M.		3600	3600	3600
Power kW (HP)	N 80/1269/EEC-ISO 1585	3,5(4,8)	5,0(6,8)	5,5(7,5)
	NB ISO 3046 - 1 IFN	3,3(4,5)	4,6(6,2)	5,1(7,0)
	NA ISO 3046 - 1 ICXN	3,1(4,2)	4,1(5,6)	4,7(6,4)
Max. torque *	Nm	10,4@2400	15@2400	16,6@2400
Fuel consumption **	g/kW.h	267	262	260
Oil consumption	l/h	0,0021	0,0035	0,0038
Capacity of standard oil sump	lt	0,9	1,2	1,2
Recommended battery	V/Ah	12/36	12/44	12/44
Dry weight	kg	28	33	33
Combustion air volume at 3600 r.p.m.	l./min	350	480	540
Cooling air volume at 3600 r.p.m.	l./min	3800	5000	5000
Max. permissible driving shaft axial load in both directions	kg.	150	200	200
Max. inclination	continuous service for up to 30 min.	25°	25°	25°
	discontinuous service for about 1 min.	35°	35°	35°
	permanent service	***	***	***

- \* Referred to N power
- \*\* Referred to NB power
- \*\*\* Depending on the application



**KD 225**



**KD 315**



**KD 350**

## CHARACTERISTICS KD 400\_440

ENGINE TYPE		400	440
Number of cylinders	N.	1	1
Bore	mm	82	86
Stroke	mm	76	76
Swept volume	Cm <sup>3</sup>	401	442
Compression ratio		20,3:1	20,3:1
R.P.M.		3600	3600
Power kW (HP)	N 80/1269/EEC-ISO 1585	7,0(9,5)	7,7(10,5)
	NB ISO 3046 - 1 IFN	6,4(8,7)	7,0(9,6)
	NA ISO 3046 - 1 ICXN	5,8(7,9)	6,4(8,7)
Max. torque *	Nm	21,3@2400	23,5@2400
Fuel consumption **	g/kW.h	262	260
Oil consumption	l/h	0,005	0,0055
Capacity of standard oil sump	lt	1,5	1,5
Recommended battery	V/Ah	12/44	12/44
Dry weight	kg	45	45
Combustion air volume at 3600 r.p.m.	l./min	580	635
Cooling air volume at 3600 r.p.m.	l./min	5500	5500
Max. permissible driving shaft axial load in both directions	kg.	200	200
Max. inclination	continuous service for up to 30 min.	25°	25°
	discontinuous service for about 1 min.	35°	35°
	permanent service	***	***

- \* Referred to N power
- \*\* Referred to NB power
- \*\*\* Depending on the application



## KD 400

## KD 440



CHARACTERISTICS POWER, TORQUE AND SPECIFIC FUEL CONSUMPTION CURVES

KD 225

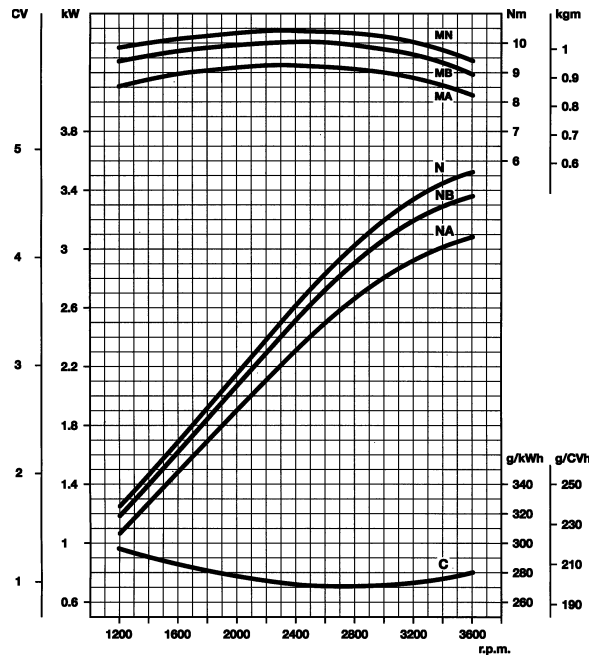

KD 315

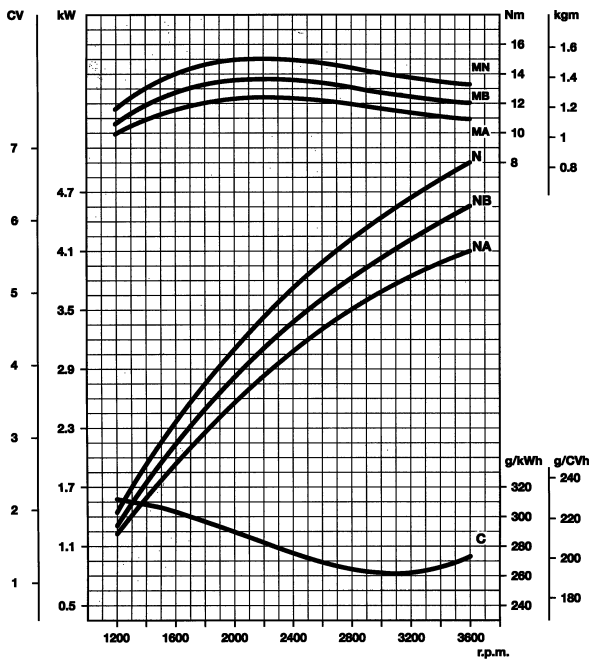

KD 350

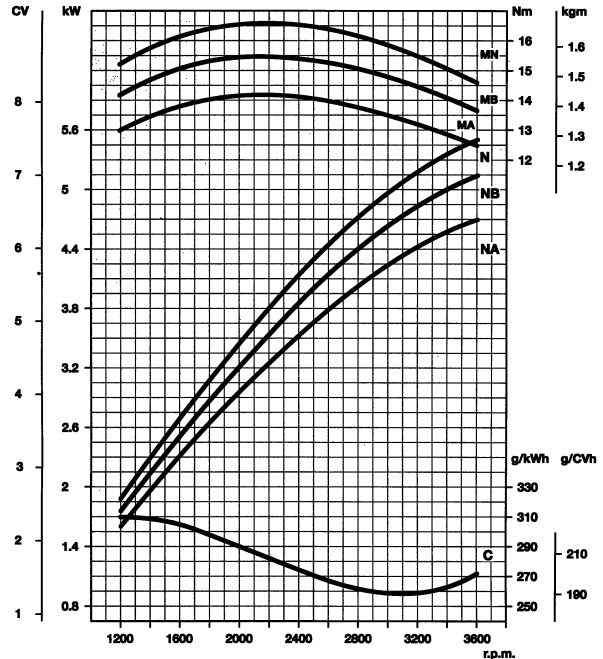

**N (80/1269/EEC - ISO 1585) AUTOMOTIVE RATING :** Intermittent operation with variable speed and variable load.

**NB (ISO 3046 - 1 IFN) RATING WITH NO OVERLOAD CAPABILITY:** continuous light duty operation with constant speed and variable load.

**NA (ISO 3046 - 1 ICXN) CONTINUOUS RATING WITH OVERLOAD CAPABILITY:** continuous heavy duty with constant speed and constant load.

**MN** Torque at N power.

**C** Specific fuel consumption at NB power.

The above power values refer to an engine fitted with air cleaner and standard muffler, after testing and at the environmental conditions of 20°C and 1 bar.

Max. power tolerance is 5%.

Power decreases by approximately 1% every 100 m di altitude and by 2% every 5°C above 25°C.

**Note:** Consult REHLKO for power, torque curves and specific consumptions at rates differing from those given above.

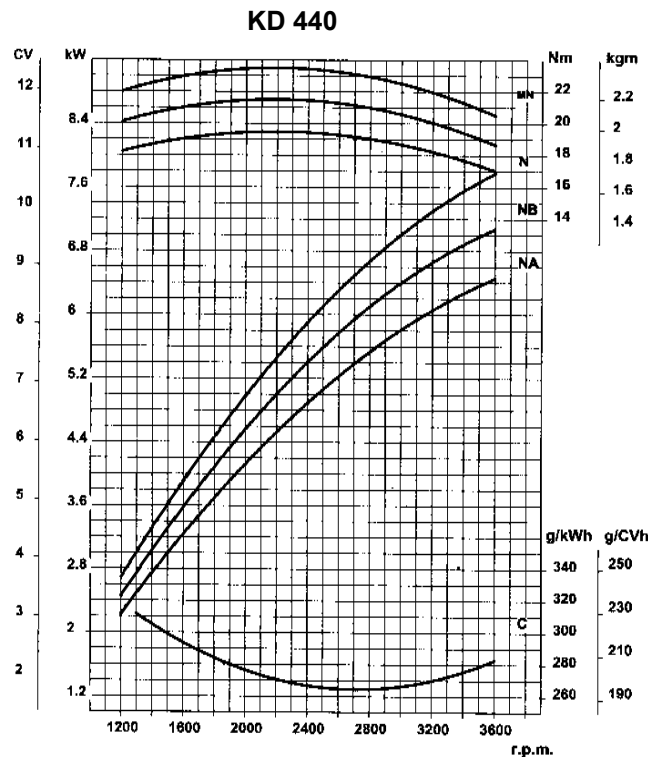
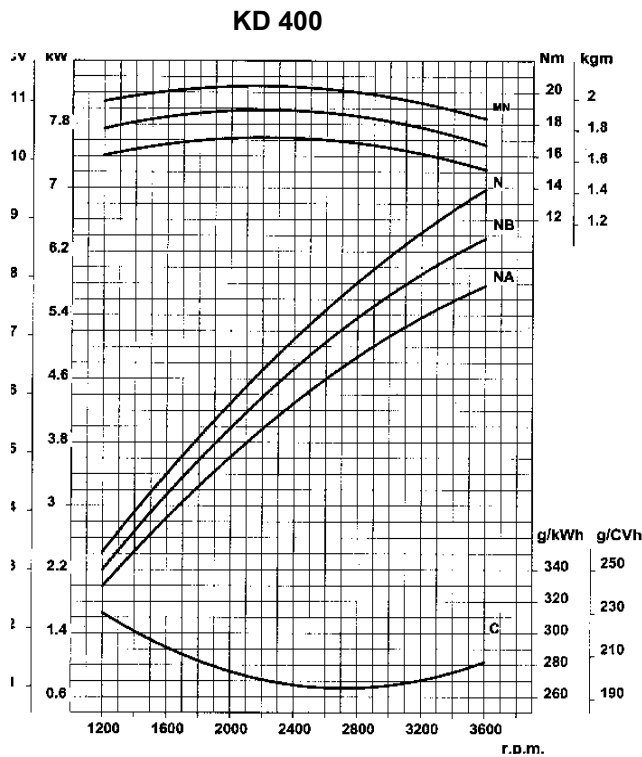
**CHARACTERISTICS POWER, TORQUE AND SPECIFIC FUEL CONSUMPTION CURVES**

**N (80/1269/EEC - ISO 1585) AUTOMOTIVE RATING** : Intermittent operation with variable speed and variable load.  
**NB (ISO 3046 - 1 IFN) RATING WITH NO OVERLOAD CAPABILITY**: continuous light duty operation with constant speed and variable load.  
**NA (ISO 3046 - 1 ICXN) CONTINUOUS RATING WITH OVERLOAD CAPABILITY**: continuous heavy duty with constant speed and constant load.  
**MN** Torque at **N** power.  
**C** Specific fuel consumption at **NB** power.

The above power values refer to an engine fitted with air cleaner and standard muffler, after testing and at the environmental conditions of 20°C and 1 bar.

Max. power tolerance is 5%.

Power decreases by approximately 1% every 100 m di altitude and by 2% every 5°C above 25°C.

**Note:** Consult REHLKO for power, torque curves and specific consumptions at rates differing from those given above.

## KD 225

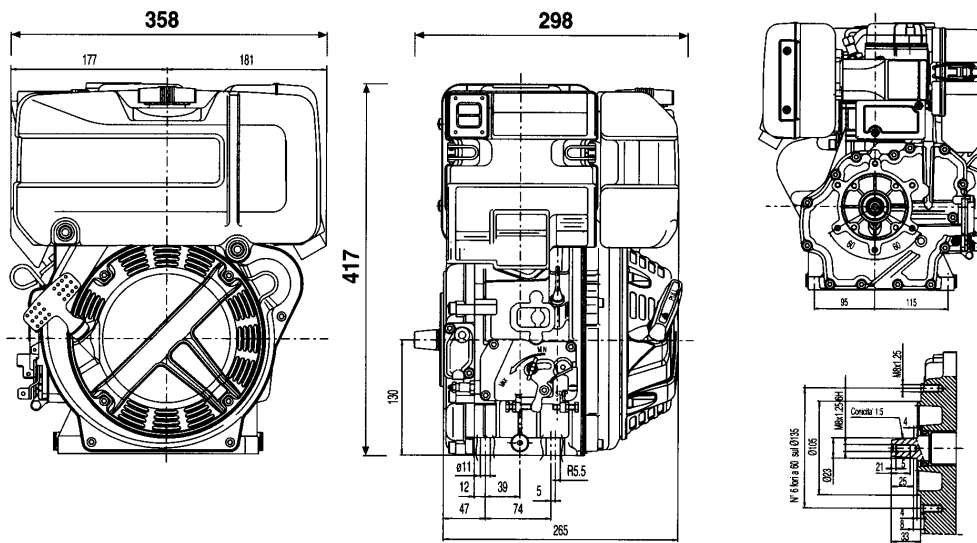

## KD 315

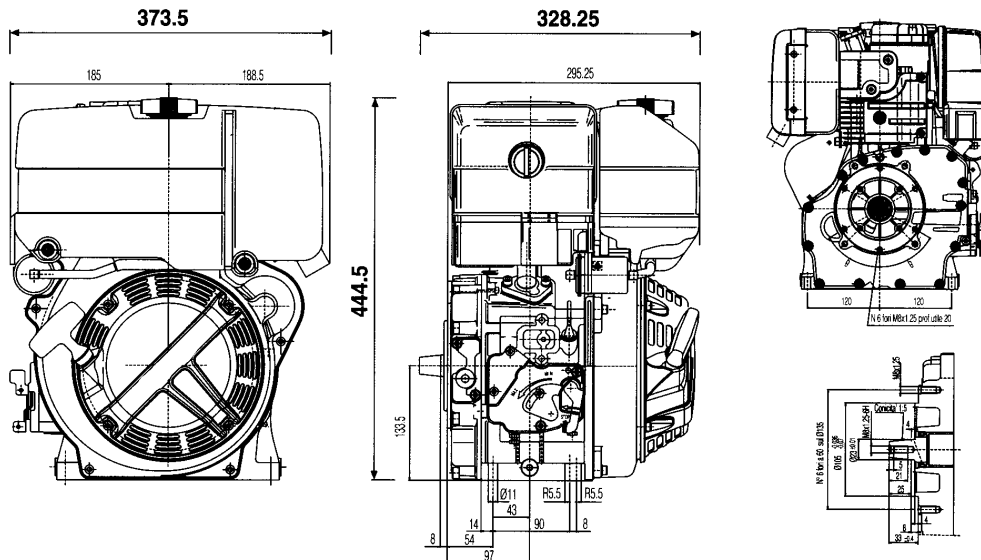

## KD 350

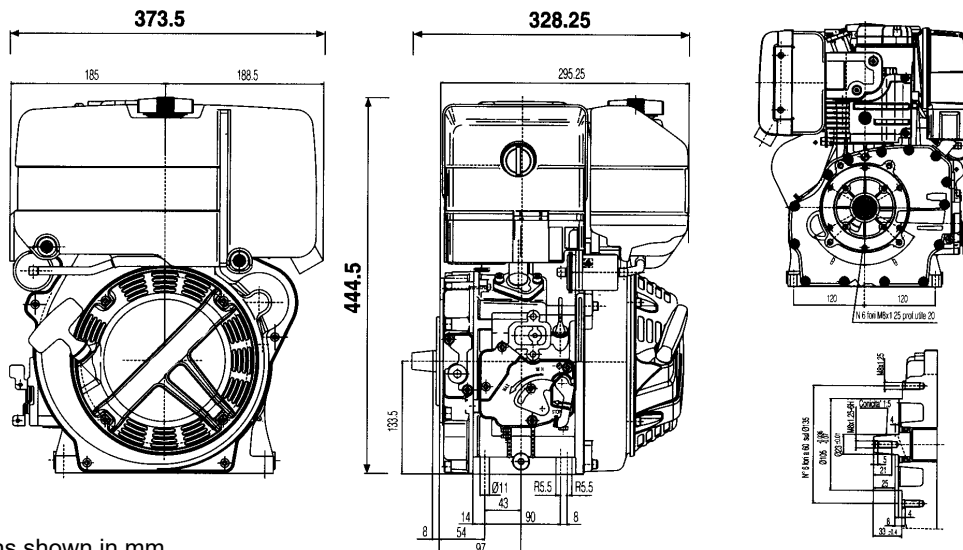

Note : Dimensions shown in mm

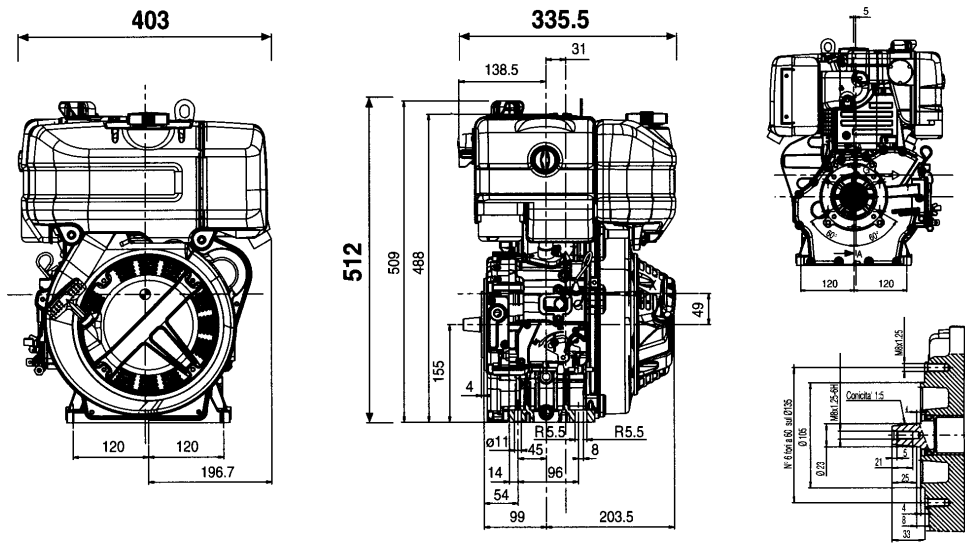
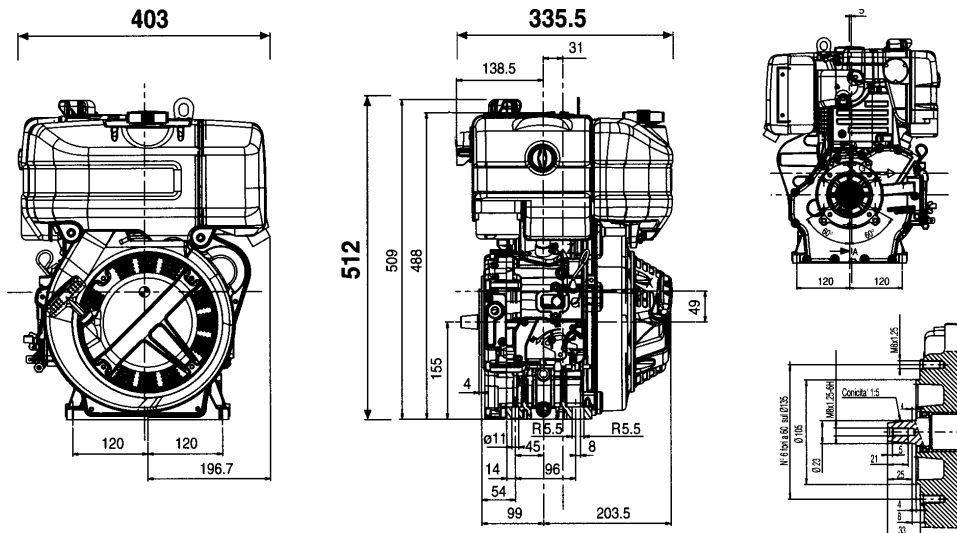
**KD 400**

**KD 440**

**Note:** Dimensions shown in mm.

**!** Failure to carry out the operations described in the table may lead to technical damage to the machine and/or system

## MAINTENANCE

INTERVAL (HOURS) OPERATION	COMPONENT					
			10	50	250	500
CLEANING	OIL-BATH AIR CLEANER		(*)	●		
	HEAD AND CYLINDER FINS		(*)			●
	INJECTOR					●
	AIR CLEANER OIL					
CHECK	LEVEL	OIL SUMP	(**)		●	
				●		
	VALVE/ROCKER ARM CLEARANCE					
	INJECTOR SETTING					●
REPLACEMENT	AIR CLEANER					●
		SUMP	(**)			
	OIL FILTER CARTRIDGE		(***)			●
	FUEL FILTER CARTRIDGE					●
	DRY AIR CLEANER CARTRIDGE					●
		(°)				

(\*) Under severe working conditions, clean daily.

(\*\*) Under extremely dusty conditions, change every 4-5 hours.

(\*\*\*) See recommended oil type.

(°) After the polyurethane prefilter has been serviced 6-10 times (see fig. 2 for 315-350 engines), when the clogging indicator (if installed) signals that the part must be replaced, or if it is irreparably clogged.

**!** To avoid explosions or fire outbreaks, do not smoke or use naked flames during the operations. Fuel vapours are highly toxic. Only carry out the operations outdoors or in a well ventilated place. Keep your face well away from the plug to prevent harmful vapours from being inhaled. Dispose of fuel in the correct way and do not litter as it is highly polluting.

## FUEL

When refuelling, it is advisable to use a funnel to prevent fuel from spilling out. The fuel should also be filtered to prevent dust or dirt from entering the tank.

Use the same type of diesel fuel as used in cars. Use of other types of fuel could damage the engine. The cetane rating of the fuel must be higher than 45 to prevent difficult starting. Do not use dirty diesel fuel or mixtures of diesel fuel and water since this would cause serious engine faults.

The capacity of the standard tank is:

KD 225	=	l. 3.0
KD 315	=	l. 4.3
KD 350	=	l. 4.3
KD 400	=	l. 5.0
KD 440	=	l. 5.0



**WARNINGS!**

**!** During repair operations, when using compressed air, wear eye protection.

**DISASSEMBLY AND REASSEMBLY**

Besides disassembly and reassembly operations this chapter also includes checking and setting specifications, dimensions, repair and operating instructions. Always use original REHLKO spare parts for repair operations.

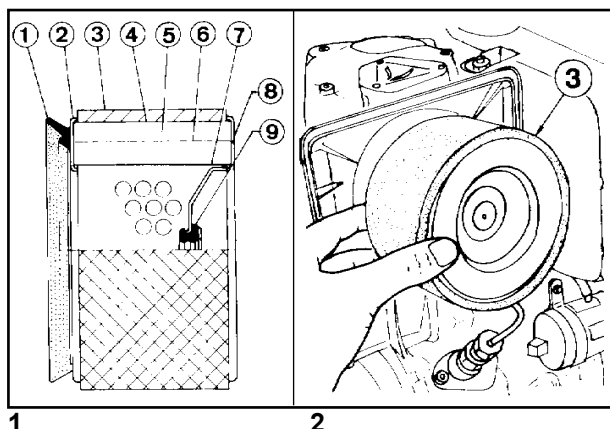

**!** Clean the filtering element with air blast. Air must be blown from inside to outside the cartridge at a distance of at least 15 cm from the paper. Lightly and repeatedly tap the element on a hard surface to eliminate all excess dirt.

**Dry air cleaner for KD 315 and KD 350**

Cartridge components:

- 1 Seal
- 2 Metallic body
- 3 Polyurethane prefilter
- 4 outer mesh
- 5 Filter media
- 6 Blade
- 7 Inside envelope
- 8 Metallic body
- 9 Inner seal

**Cartridge characteristics:**

media porosity 7  $\mu\text{m}$ , useful filtering area 1960  $\text{cm}^2$ .

**Polyurethane pre-filter characteristic:**

porosity 60 p.p.i., front area 207  $\text{cm}^2$ .

**Note:** Pre-filter 3 can undergo maintenance operations; if dirty, wash with soap and water and dry ( maximum 10 cleanings ). See page 18 for cartridge replacement.

**!** Clean the filtering element with air blast. Air must be blown from inside to outside the cartridge at a distance of at least 15 cm from the paper. Lightly and repeatedly tap the element on a hard surface to eliminate all excess dirt. Replace if irreparably clogged.

**Dry air cleaner for KD 225**

Cartridge components:

- 1 Complete cover
- 2 Filtering material
- 3 Support

Characteristics of the filtering material:

paper porosity : 3  $\mu\text{m}$

filtering area : 4400  $\text{cm}^2$

outer ring in open-cell polyurethane

See page 18 for the frequency with which the filtering material must be changed.

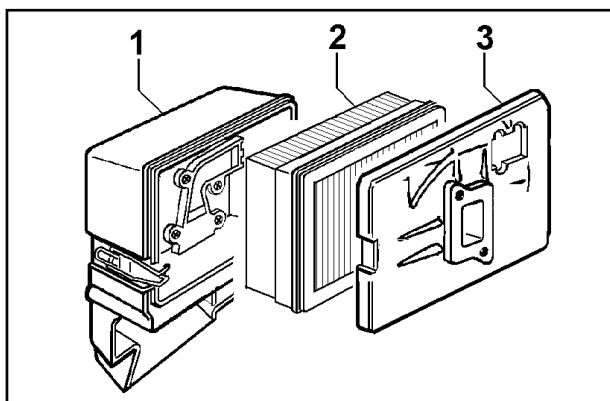

3

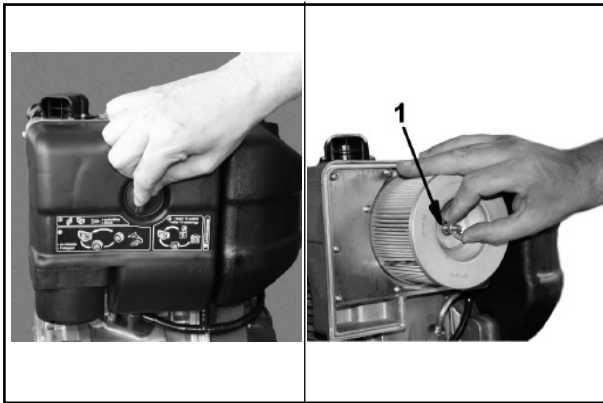

4

4a



Clean the filtering element with air blast. Air must be blown from inside to outside the cartridge at a distance of at least 15 cm from the paper.

Lightly and repeatedly tap the element on a hard surface to eliminate all excess dirt.

#### Dry air cleaner for KD 400-440

Open air cleaner (fig. 4).

Unscrew the wing nut **1** (fig. 4a) and remove the filter element (fig. 5).

Check the rubber seal is undamaged **A** (fig. 5a)

Clean the filtering element with air blast.

If the filtering element has been already cleaned other times, or if it is irreparably clogged, throw it away and replace .

Refit the air filter and make sure the seal **A** is properly inserted, then tighten the wing nut **1**.

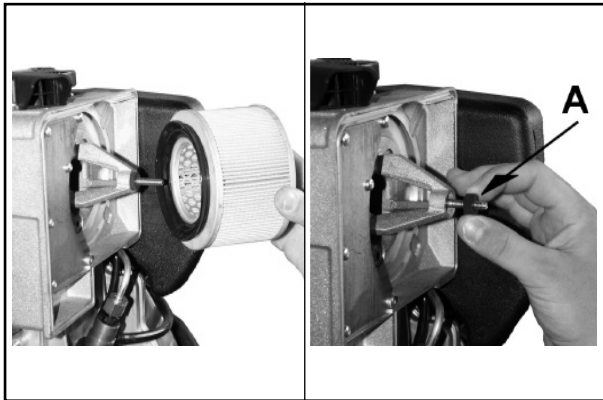

5

5a



Make sure that the filter is mounted in the correct way otherwise dust and other impurities could infiltrate into the intake ducts.



6

#### Prefilter for dry air filter

Remove and clean the pre-filter if clogged.



7

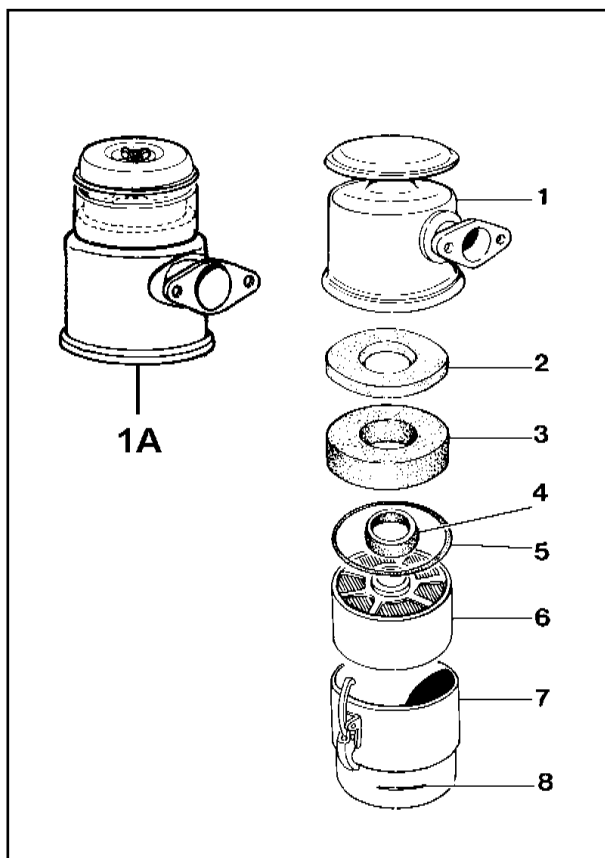

Never clean the filtering element **6** using solvents with a low flash point. This could cause an explosion !



Make sure that the retention rings **4 - 5** are in a good condition and replace them if they are damaged.

#### Oil-bath air cleaner (optional)

Components:

- 1 Upper shell
- 1A Upper unit with separator pre-filter
- 2 Secondary filter element
- 3 Primary polyurethane
- 4 Internal seal ring
- 5 External rubber gasket
- 6 Lower metal filter element
- 7 Lower cup
- 8 Oil level gauge

#### Characteristics of filter element 2:

made of Viledon synthetic fabric, porosity 120 gr/m<sup>2</sup>, resin-covered.

#### Characteristics of filter element 3:

open-celled polyurethane foam; porosity 45 P.P.I..

Both filter elements can be washed with soap and water for a maximum of 10 times.

Wash the metal filter **6** with Diesel fuel Blow out excess fuel with compressed air. See pages 14 and 15 for periodic maintenance details and oil replacement.

8

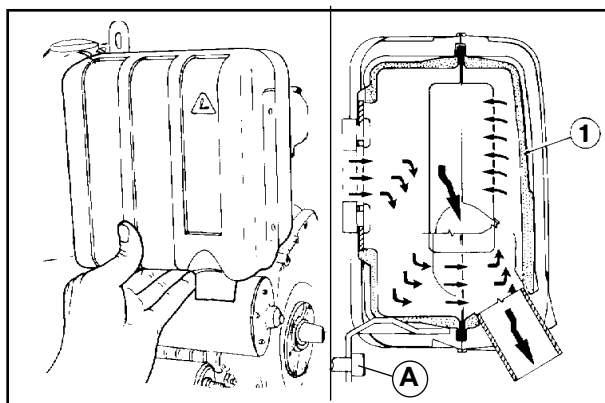

Allow the exhaust manifold to cool before demounting it in order to prevent scorching and burns.

#### Muffler

When reassembling replace the exhaust manifold gaskets.

Tighten nuts to 25 Nm.

The muffler design includes internal sound absorbing panels.

Tighten the bearing nuts and screw **A** to a 25 Nm torque value.

9

10

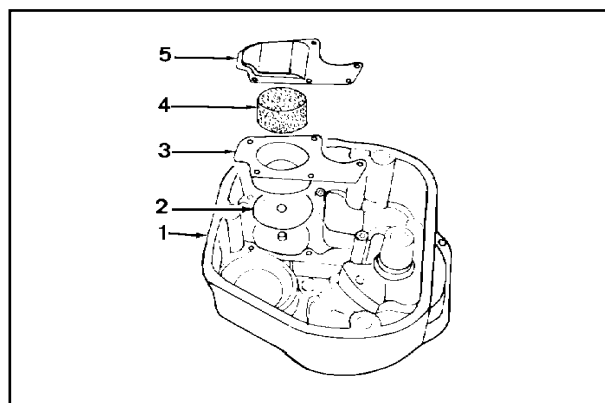

#### Rocker arm cover breather system

The crankcase breather system is located inside the rocker arm cover. Check that diaphragm **2** is intact ; wash with Diesel oil and blow through the small mesh element **4** with compressed air.

When reassembling fix box **3** with Loctite " Form-a- gasket No. 6" and screw plate **5**. Also see below.

11

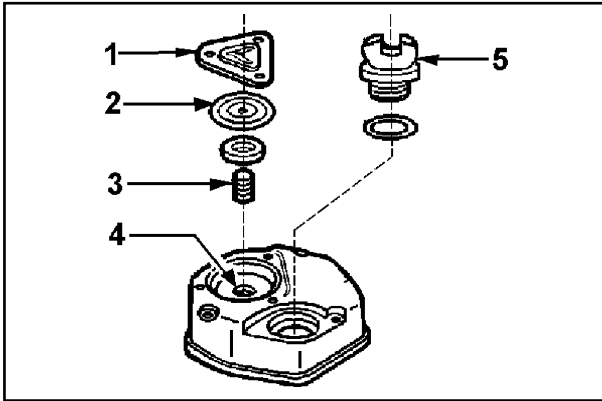

12



Always check the the spring and valve to make sure they are in a good conditions.

#### Rocker arm cover - Breather ricirculation

Crankcase vapor recirculation occurs through duct **4**.

If the air filter clogs, the increased intake vacuum could suck oil through duct **4** into the combustion chamber, causing the engine to operate at a runaway rate. This is prevented by valcuum valve **2** which, when the vacuum increases, overcomes the resistance of spring **3** and shuts the duct **4**.

Make sure that oil plug **5** is correctly closed.

Refit cover **1** and tighten rocker arm cover to 10 Nm.

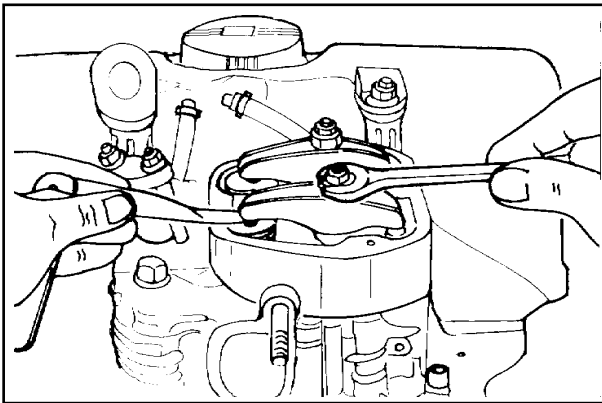

13

#### Valve/rocker arm clearance ( KD 225-315-350 )

Set valve/rocker arm clearance when the engine is cold: bring piston to top dead center on the compression stroke and set clearance at 0.10-0.15 mm using a thickness gauge. Tighten lock nut.

**N.B.:** Since an automatic decompression device is available on the exhaust lobe, manually rotate the engine until the tappets are at lowest point.

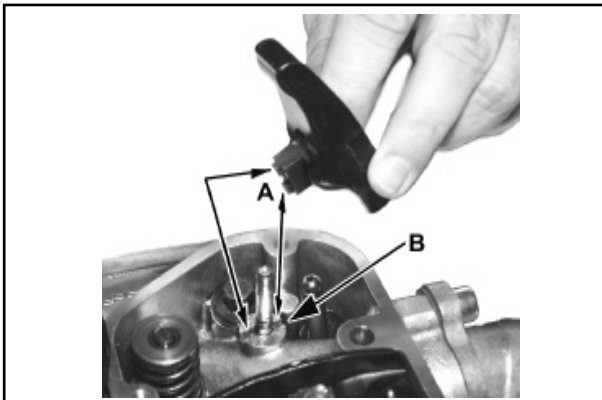

13a



**The engines KD 400 and 440 have hydraulic tappets, therefore no adjustment is required.**

When replacing the rocket arms, position the piston at the bottom dead centre and tighten the fixing screw gradually to adjust the hydraulic tappets.

While tightening, make sure that **A** fits correctly into **B** (fig. 13a).

The adjusting screw pin should be tightened to 20 Nm.



13b



**Do not start the engine for approximately 4 hours to allow the hydraulic tappets to settle completely.**

Once the tappets have settled, tighten the bolt to 10Nm.

### Hydraulic tappets KD 400-440

Distribution uses hydraulic tappets for automatic adjustment of valve clearance. The figure shows the tappet used in KD 400 engines.

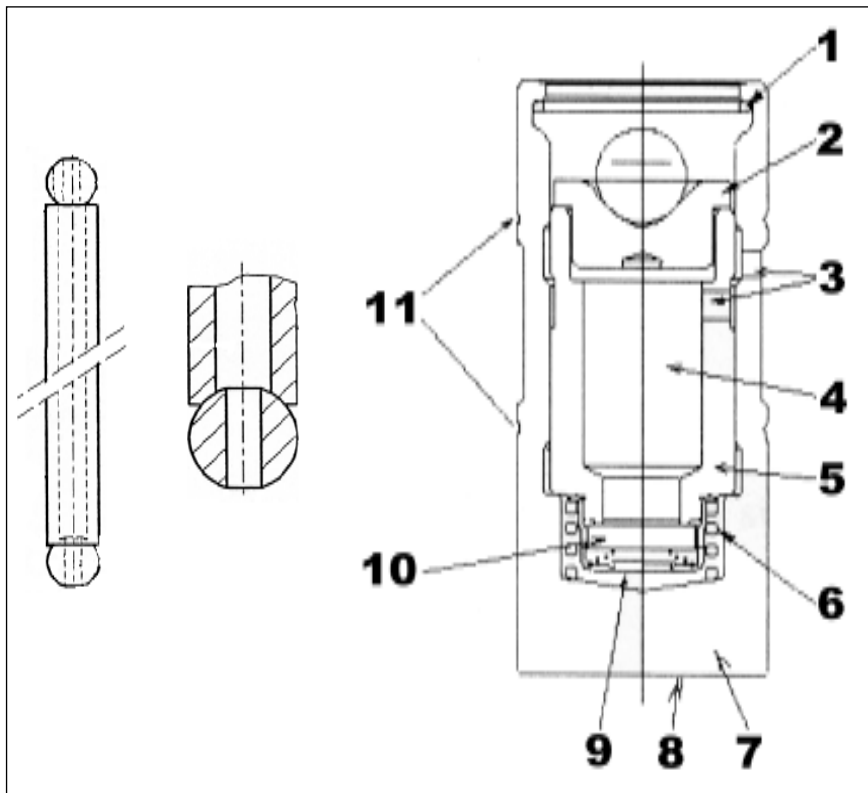

#### Caption

- 1- Lock ring
- 2- Upper collar
- 3- Oil inlet holes
- 4- Low-pressure chamber
- 5- Piston
- 6- Play-recovery spring
- 7- Case
- 8- Area to be lubricated
- 9- High-pressure chamber
- 10- Check valve
- 11- Identification marks

Fill the low-pressure chamber through the oil inlet holes.

If clearance occurs while running, as the tappet returns to the base of the camshaft, the play-recovery spring stretches out, keeping all timing system parts close together.

While the play-recovery spring is stretching, the check valve lets oil into the high-pressure chamber from the low-pressure chamber, to recover the increase in volume in the high-pressure chamber, caused by the stretching spring. In this way, since oil is practically uncontrollable, when the valve is next opened, play will be completely recovered.

During each cycle a small amount of oil is drawn from the high-pressure chamber into the piston coupling wall with the case and then, passing through the internal inlet hole, flows into the low-pressure chamber.

The tappet is shortened by less than 0.1mm each cycle. This allows the tappet to make up the reduction in play while the engine is running.

It is not necessary for the oil to reach the tappet on the downward stroke: light pressure is enough to ensure that air bubbles do not form.

The tappet may be supplied with the high-pressure chamber full or empty. The low-pressure chamber is always empty.

The tappet should always be handled in an upright position to prevent the high-pressure chamber from emptying.

The surface that comes into contact with the cam should be lubricated generously during assembly using AS COMPUND 40 type MOLYSLIP (see figure). This operation is important to ensure correct lubrication right from the start.

The distribution system is assembled as follows:

- a) Make sure that the piston is between the Bottom Dead Centre and the halfway point
- b) Insert the rods into position on the tappets
- c) Mount the rocker arm and the joint block, then tighten the fixing nut to the specified torque
- d) DO NOT START THE ENGINE FOR AT LEAST 4 HOURS AFTER TIGHTENING THE ROCKER ARMS because the valve-piston contact may be put at risk.

The tappet is unloaded when it is possible to shift the internal part by 3.5±4 mm using a force of 30 Nm.

If the tappets are loaded (for example if they have been left in a horizontal position) the engine will be noisy during the first few minutes after switching on, until the air has been completely drained out of the inside of the tappets themselves.

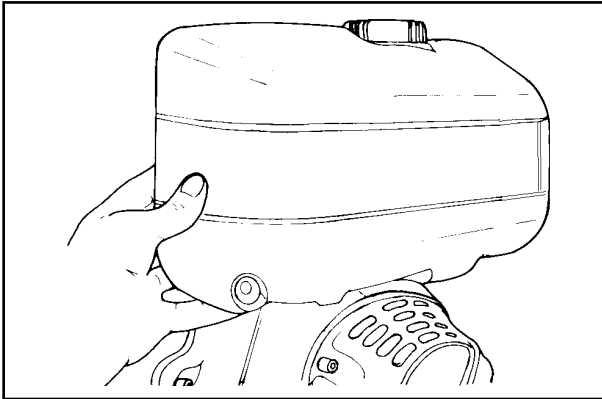

14

**!** To avoid explosions or fire outbreaks, do not smoke or use naked flames during the operations. Fuel vapours are highly toxic. Only carry out the operations outdoors or in a well ventilated place. Keep your face well away from the plug to prevent harmful vapours from being inhaled. Dispose of fuel in the correct way and do not litter as it is highly polluting.

**Tank**

Unscrew the upper and lower studs and remove the washers, which otherwise might make removal of the tank difficult. Next disconnect the fuel and air bleeding tubes.

Completely empty the tank to make sure that no impurities remain. When reassembling tighten the upper nuts to 15 Nm.

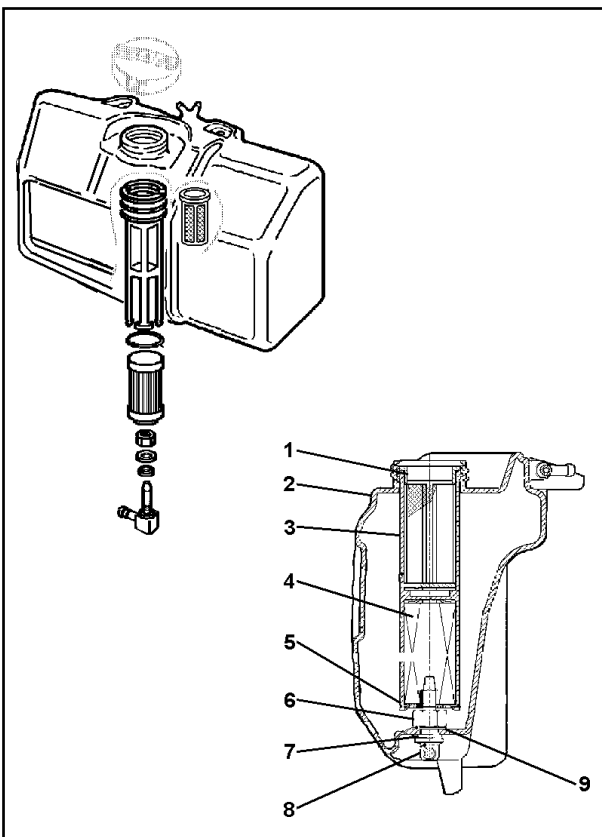

15

**Fuel filter KD 225-400-440 (version with internal filter)**

- 1 Fuel filter
- 2 Fuel tank
- 3 Filter sleeve
- 4 Filter cartridge
- 5 Flush ring
- 6 Nut
- 7 Union seal
- 8 Diesel fuel outlet union
- 9 Flat washer

See page 18 for the frequency with which the fuel filter must be replaced.

See fig. 99 for the dimensions.

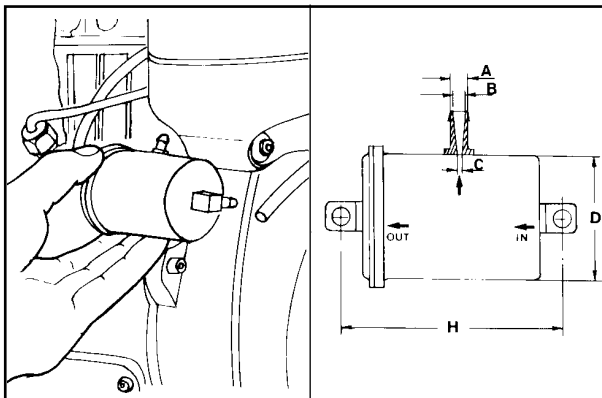

16

17

**Fuel filter for KD 225 - 315 - 350 - 400 - 440 (version with external filter)**

Loosen the clamps and disconnect the hoses.

**Characteristics**

Filtering area  $\geq 390 \text{ cm}^2$   
 Paper porosity  $\leq 7 \mu \text{ m}$ .  
 See page 18 for replacement  
 See fig. 98 for dimensions.

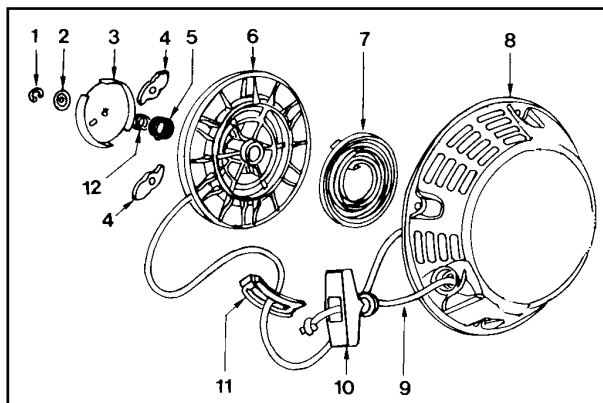

18

### Re-coil starting

#### Operation:

When pulling handle **10**, thanks to the action of friction spring **12**, teeth **4** protrude from cap **3**. After starting these teeth go back to the initial position because the cap rotates. Rope **9** is re-wound around pulley **6** by means of spring **7**.

#### Components:

1 Retainer	7 Spring
2 Washer	8 Guard
3 Cap	9 Rope
4 Flyweights	10 Handle
5 Spring	11 Rope guide
6 Pulley	12 Spring

**Note:** there are two kinds of guards **8**, one for engines with an rpm above 2000 and one with fewer cooling channels for engines with a lower rpm

On reassembly, tighten the screws to 10Nm.

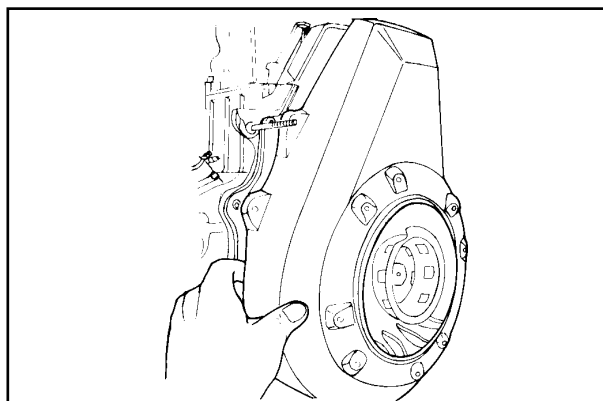

19

### Shroud

The shroud and the metal sheeting outside the cylinder are made of special material (ANTIPHON) which absorbs noise, thus reducing total engine sound pressure levels.

When refitting tighten shroud screws to 10 Nm.

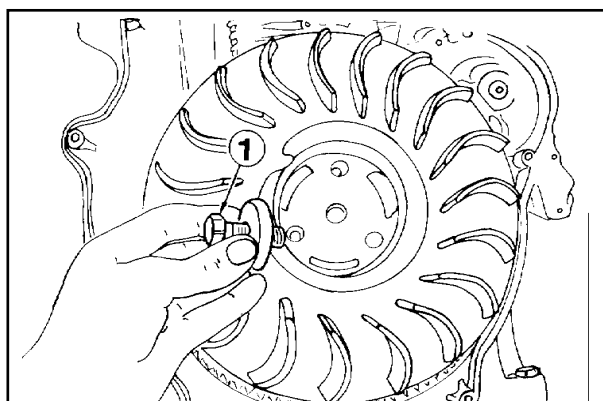

20



During the demounting phases, pay particular attention to prevent the flywheel from dropping as this could seriously injure the operator.

Wear protective goggles when removing the flywheel ring.

### Flywheel

Unscrew bolt **1** in a clockwise direction.

Remove the flywheel with a puller.

Make sure that the tapered surface that couples to the drive shaft is not damaged.

To remove the starter rim, it is advisable to cut it into several parts with a hacksaw and to then use a chisel. To replace, slowly heat for 15-20 minutes to a temperature of 300°C max.

Fit the rim into the flywheel housing. make sure that it rests evenly against the support of the housing itself.

Allow it to slowly cool.

When refitting tighten bolt **1** to 150 Nm.

See pages 34 and 35 for injection timing reference marks.

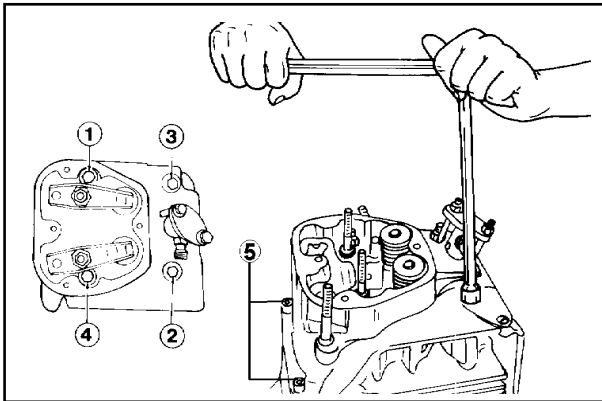

21



Do not demount when hot or the part could become deformed.

### Cylinder head

If the surface of the cylinder head is deformed, flatten it by removing 0.2 mm of material at most.

Always replace the seal. See figs 46-47-48-49-50 when selecting the thickness. The bolts must be tightened in different phases for the various engines, in compliance with the order shown in the figure:

First tighten the 4 screws M10, then the 2 side screws M6.

Lubricate the shanks of the bolts, under their heads and the washers with engine oil. Do not use too much oil. Oil that deposits in the threaded hole on the cylinder block could become pressurized during the tightening phase, sensibly diminishing the driving force. Always make sure that the holes on the cylinder block are dry and clean.

<p><b>Engine KD 225</b></p> <p>1st phase: tighten all the bolts to a 30 Nm torque value in a crossed fashion.</p> <p>2nd phase: unscrew all the bolts by 180°.</p> <p>3rd phase: tighten all the bolts to a 20 Nm torque value in a crossed fashion.</p> <p>4th phase: make a 52° turn in the same order as the 3rd phase.</p> <p>5th phase: tighten the 2 side bolts (5) to a 10 Nm torque value</p>	<p><b>Engine KD 350</b></p> <p>1st phase: tighten all the bolts to a 30 Nm torque value in a crossed fashion.</p> <p>2nd phase: unscrew all the bolts by 180°.</p> <p>3rd phase: tighten all the bolts to a 20 Nm torque value in a crossed fashion.</p> <p>4th phase: make a 60° turn in the same order as the 3rd phase.</p> <p>5th phase: tighten the 2 side bolts (5) to a 10 Nm torque value</p>
<p><b>Engine KD 315</b></p> <p>1st phase: tighten all the bolts to a 30 Nm torque value in a crossed fashion.</p> <p>2nd phase: unscrew all the bolts by 180°.</p> <p>3rd phase: tighten all the bolts to a 20 Nm torque value in a crossed fashion.</p> <p>4th phase: make a 72° turn in the same order as the 3rd phase.</p> <p>5th phase: tighten the 2 side bolts (5) to a 10 Nm torque value</p>	<p><b>For KD 400 and 400 engines</b></p> <p>1<sup>st</sup> phase: tighten all screws crosswise to 20Nm.</p> <p>2<sup>nd</sup> phase: tighten the screws in the same order to 40Nm.</p> <p>3<sup>rd</sup> phase: tighten all screws in the same order to 50Nm.</p> <p>4<sup>th</sup> phase: following the same order as in phase 3, rotate 60°.</p> <p>5<sup>th</sup> phase: following the same order as in phase 4, rotate 60°.</p> <p>6<sup>th</sup> phase: tighten the 2 side screws (5) to 10 Nm</p>

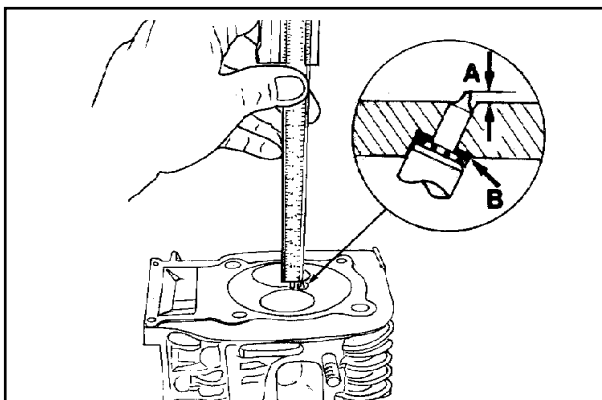

22

### Injector projection

The end of nozzle **A** should project 2,5 mm for KD 225-315-350 and 3,0÷3,5 mm for KD 400-440 from the cylinder head plane.

Adjust with copper gaskets **B** with thickness of 0.5, 1 and 1.5 mm

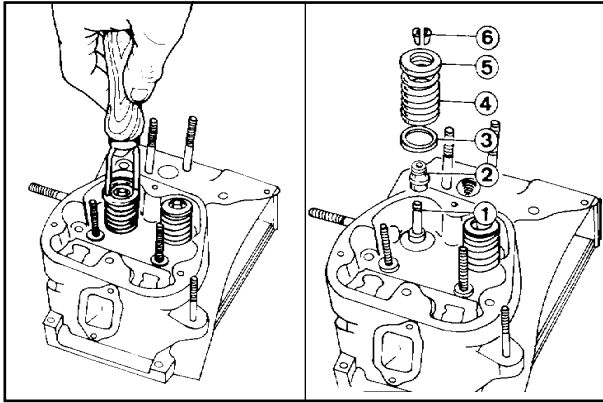

### Valves - Disassembly

Components:

- 1 Valve stem
- 2 Oil seal
- 3 Spring washer/set
- 4 Spring
- 5 Cap
- 6 Half collets

**Note:** To remove half collets place a suitable plate under the valve head and press down firmly as indicated in the figure.

23

24

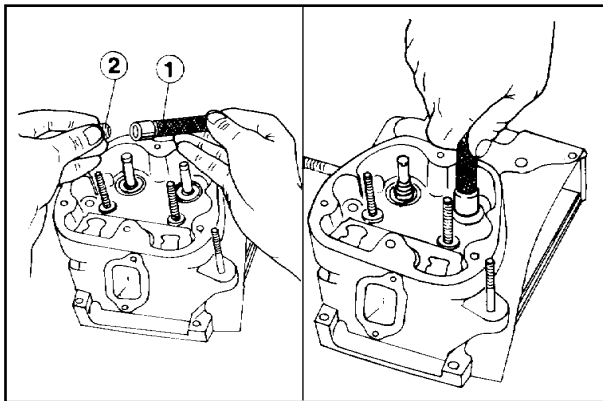

### Valves - Oil seal in valve guide

To prevent seal 2 from being deformed when the valve guide is mounted, fit it into tool 1 serial N° 7107-1460-047 after having thoroughly lubricated it, then proceed as indicated in the figure.

25

26

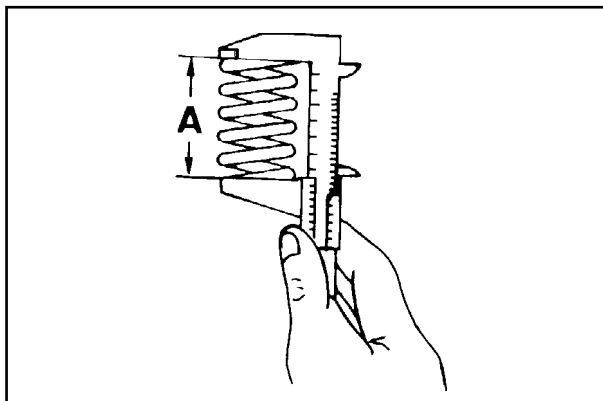

### Valve, springs

Measure the free length with a caliper.

#### Engine KD 225-315-350

Free length **A** = 33,72

#### Engine KD 400-440

Free length **A** = 34,88

**Note:** Replace the spring if the free length **A** is 1 mm less than specified.

27

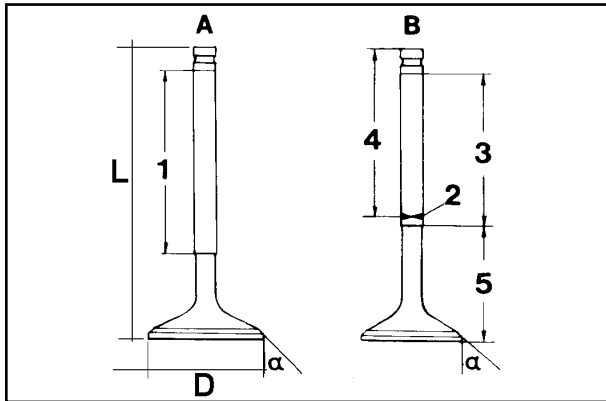

28

**Valves, characteristics**
**Intake valve A**

	225	315 - 350	400 - 440
	Base Material X 45 Cr Si8 uni3992		
1	Chrome Plated		
D	31,4 ÷ 31,6	35,8 ÷ 36,0	37,6 ÷ 37,8
L	81,8	91	92,0 ÷ 92,4
a	45° 35' ÷ 45 65'		

**Exhaust valve B - Stem and head are of two different materials**

	225 - 315 - 350 - 400 - 440
2	Weld Joint
3	Chrome Plated
4	Base Material → X 45 Cr Si8 UNI3992
5	Base Material → X 70 Cr Mn Ni21.6 UNI3992
a	45° 35' ÷ 45 65'

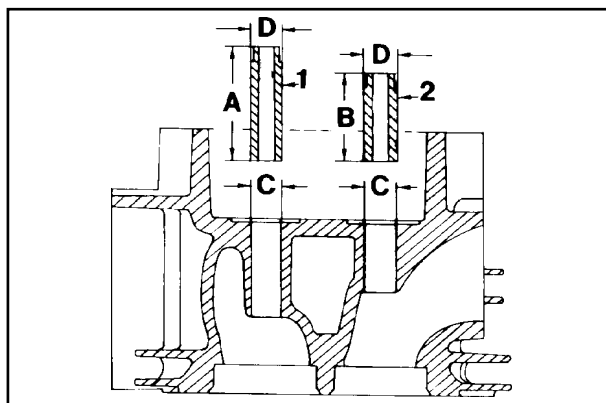

29

**Valves, guides and housings**

- 1 Intake guide
- 2 Exhaust guide

**Dimensions (mm) for KD 315-350-400-440**

A = 40  
 B = 31  
 C = 11.000-11.018  
 D = 11.040-11.055

**Dimensions (mm) for KD 225**

A = 35  
 B = 30  
 C = 10.000-10.020  
 D = 10.040-10.055

**Note:** Valve guides with outer diameters increased by 0.5 mm are also available as spares. In this case, housing C must be increased by 0.5 mm for assembly purposes.

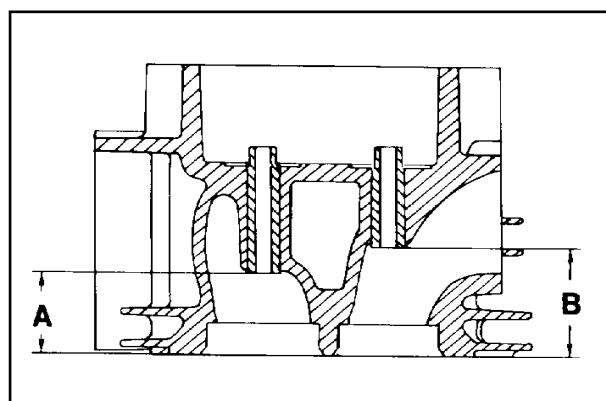

30

**Valves, guide insertion**

Heat the block to a temperature of 160°-180°  
 Force the guides, considering distance A and B in relation to the block surface.

**Dimensions (mm) for KD 315-350-400-440**

A = 25.8-26.2  
 B = 34.8-35.2

**Dimensions (mm) for KD 225**

A = 23.8-24.2  
 B = 28.8-29.2

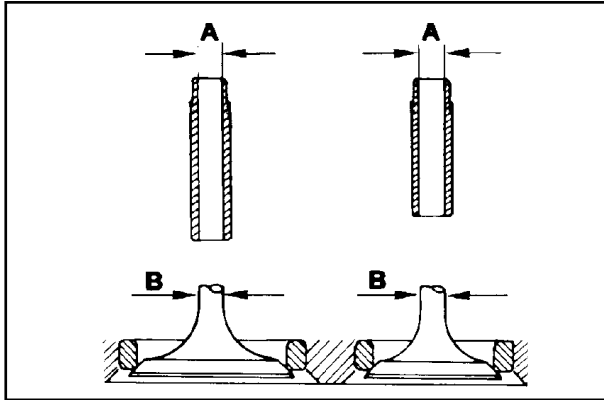

31

**Dimensions and clearance between guides and valve stems (mm)**

	225	315-350	400-440
A	6,020÷6,035	7,025÷7,040	
B	5,985÷6,000	6,985÷7,000	6,985÷7,000
(A-B) Clearance	0,020÷0,050	0,025÷0,055	
(A-B) Limit	0,14		

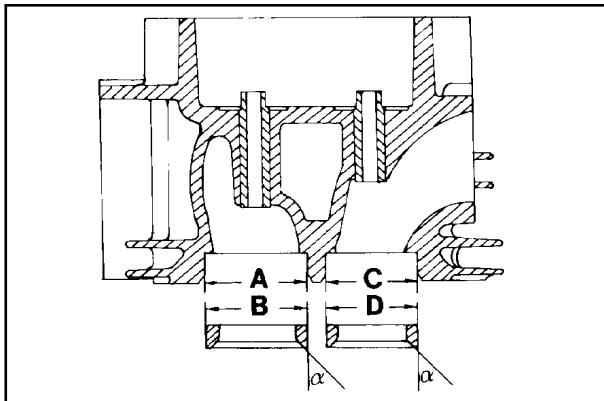
**Valves seats and valve seat bores**

32

**Dimensions (mm)**

	225	315-350	400-440
A	32,50÷32,51	37,00÷37,01	39,00÷39,01
B	32,60÷32,62	37,10÷37,12	39,10÷39,12
C	28,50÷28,51	33,00÷33,01	35,00÷35,01
D	28,60÷28,62	33,10÷33,12	35,10÷35,12

**Note :** Since the seats are supplied pre-finished, they must not be machined after having been inserted.

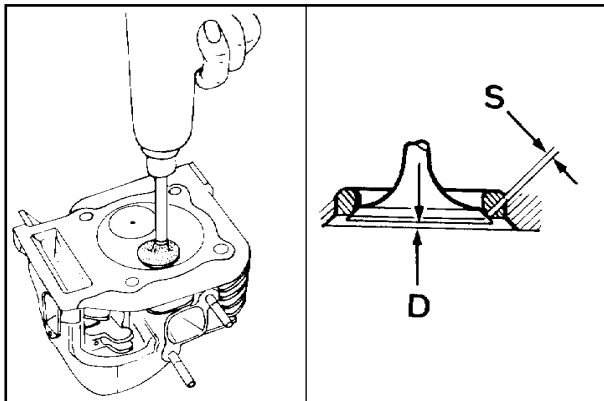

33

34

**Valve seat lapping**

After cutting valve seats, lap valve seats with fine lapping compound. The sealing surface **S** should not exceed 2 mm.  
 Lowering valve for KD 225-315-350 (D = 0.55÷0.85 mm).  
 Lowering valve for KD 400-440 (D = 0.35÷0.65 mm).  
 Wear limit 1.5 mm.

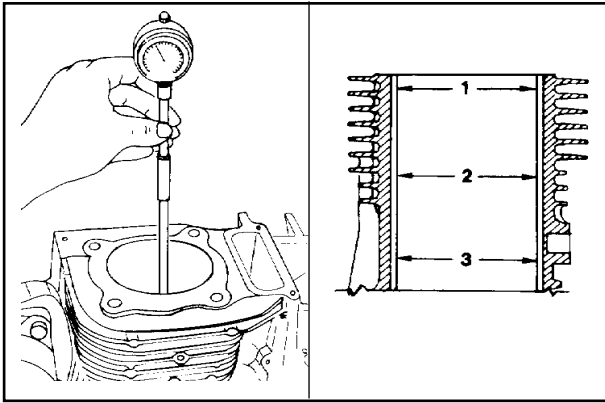

35

36

**Cylinder**

Set a bore gauge to zero with a calibrated ring.  
 Check diameter at **1**, **2** and **3**; repeat the operation at the same points after turning the bore gauge 90°.  
 If wear exceeds the max. given value by 0.05, bore the cylinder and fit oversize piston and rings.  
 See fig. 40 and 41 for cylinder diameter values.

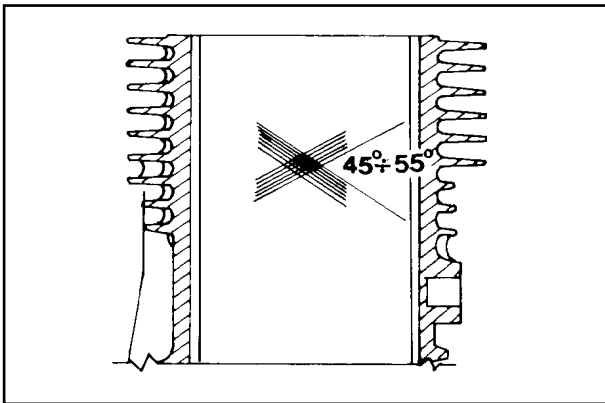

37

**!** Do not manually hone the cylinder bore surfaces with emery cloth or other means.

**Cylinder roughness**

The cross-hatch pattern should be at an angle of 45°-55°; lines should be uniform and clear in both directions.  
 Average roughness must range between 0.5 mm 1 µm.  
 The cylinder surface which comes into contact with piston rings should be machined with the plateau method.

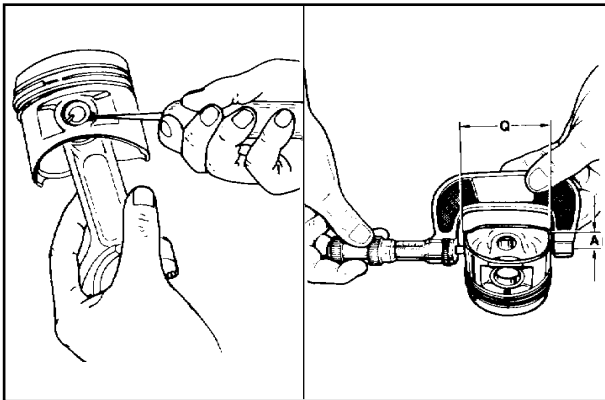

38

39

**Piston**

Being of low expansion type, the piston allows small clearances between piston and cylinder and, thus, oil consumption is reduced.  
 Remove circlips and piston pin.  
 Remove piston rings and clean grooves.  
 Measure diameter **Q** at the **A** distance from the skirt bottom (**A** = 12 mm).  
 Replace the piston and piston rings if wear on the diameter is 0.05 mm more than the minimum value given (see table in fig. 40-41).

**Note:** Oversize pistons of 0.50 and 1.00 mm are available.

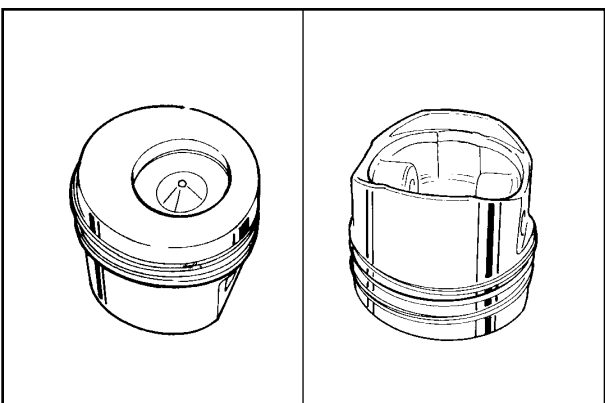

40

41

**Dimensions of pistons and cylinders, Logo**

Logo can be found inside the piston

	Ø Cilinders	Ø Piston	Clearance
<b>225</b>	69,00÷69,015	68,955÷68,970	0.03÷0.06
<b>315</b>	78,00÷78,15	77,955÷77,970	0.03÷0.06
<b>350 - 350EPA</b>	82,00÷82,015	81,955÷81,970	0.03÷0.06
<b>400</b>	82,00÷82,015	81,955÷81,970	0.03÷0.06
<b>400EPA</b>	82,00÷82,015	81,925÷81,940	0.06÷0.09
<b>440 - 440EPA</b>	86,00÷86,015	85,955÷85,970	0.03÷0.06



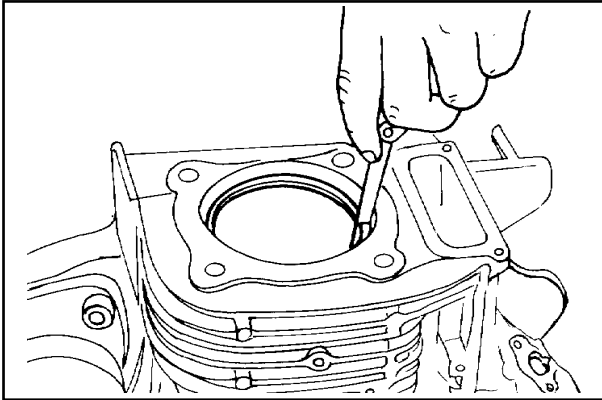

42

**Piston rings, distance between the tips (mm)**

Fit the piston ring into the top part of the cylinder and measure the distance between the tips.

Engine	Piston rings	Value		
		stamped - GOE	stamped - ko	stamped - N
<b>225</b>	1st piston ring (nitrided)	0.20÷0.40		
	2nd piston ring *	1.00÷1.50	0.30÷0.50	
	3rd piston ring, oil scraper (nitred)	0.25÷0.50		
<b>315</b>	1st piston ring (chromated)	0.30÷0.50		
	2nd piston ring (torsional)	0.30÷0.50		
	3rd piston ring, oil scraper	0.25÷0.50		
<b>350</b>	1st piston ring (nitrided)	0.20÷0.35		
	2nd piston ring *	1.00÷1.50	0,30÷0,50	
	3rd piston ring, oil scraper (nitred)	0.25÷0.50		
<b>400</b>	1st piston ring (nitrided)	0.20÷0.35		
	2nd piston ring *	1.00÷1.50	0.30÷0.50	
	3rd piston ring, oil scraper (nitred)	0.25÷0.50		
<b>440</b>	1st piston ring (chromated)		0.20÷0.35	
	2nd piston ring (torsional)		0.30÷0.50	
	3rd piston ring, oil scraper		0.20÷0.40	

Wear limit 1 mm - for the 2nd piston ring of kD 225 and KD 350 engines, the wear limit is 2.0 mm.

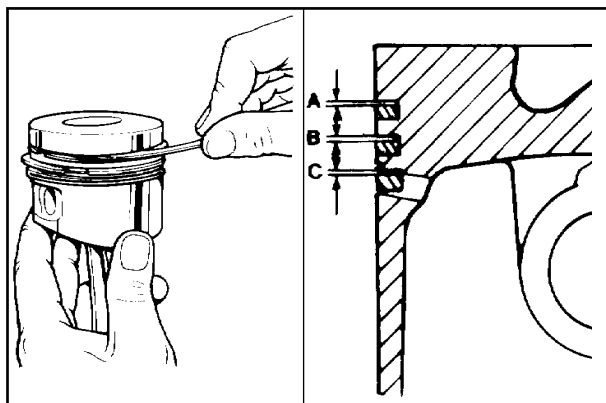

Piston rings, play between the slots (mm)

	225	315	350-400	440
A	0.07÷0.115	0.07÷0.10	0.035÷0.11	0,07÷0,11
B	0.04÷0.08	0.05÷0.08	0.050÷0.09	0,05÷0,09
C	0.03÷0.07	0.04÷0.075	0.030÷0.087	0,03÷0,07

Replace the piston or piston rings if the value exceeds the maximum limit.

43

44

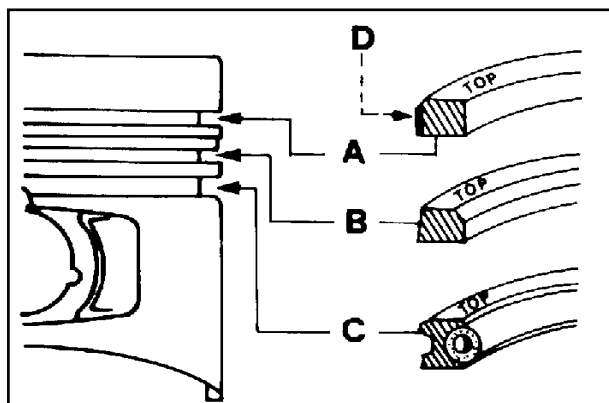

Piston rings, assembly order

A = 1st Chromium plated piston ring (nitrided for 225-350-400)

B = 2nd piston ring (torsional)

C = 3rd piston ring (oil scraper) (nitrided for 225-350-400)

D = Chromium plated zone

**Note:** If a word (top, or some other word) is written on the surface of a piston ring, mount that surface upwards.

Before inserting the piston into the cylinder, oil and turn the piston rings so that the cuts are staggered 120° to each other.

In KD 350 and KD 225 engines, the second piston ring is not torsional, while the first and third piston rings do not have chromium plated zones but are nitrided.

45

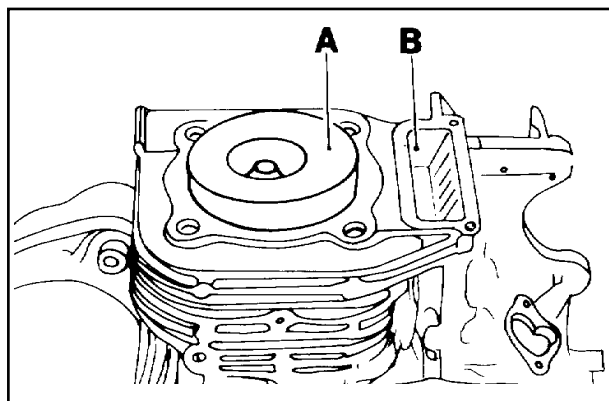

Lubricate the following parts with oil before mounting: the piston pin, the piston, the cylinder and the big-end bearing

#### Piston - Refitting

Connect piston to connecting rod, lubricate piston pin and introduce it into the piston/connecting rod assembly by exerting pressure with your thumb.

Fit both piston pin circlips and check that they are well seated.

When introducing both the connecting rod and the piston into the cylinder make sure that the larger crown surface A (if compared to the combustion chamber) is on the same side as the pushrod opening B.

46

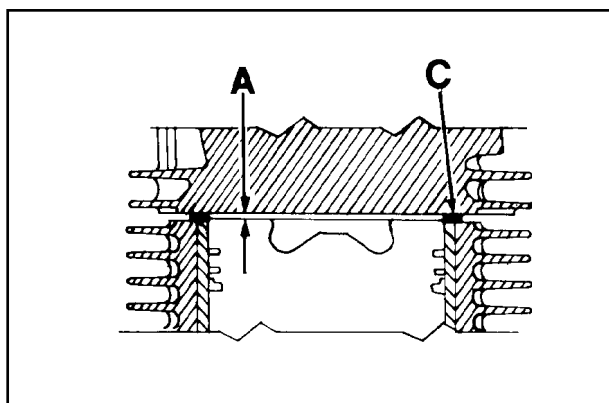

#### Clearance

A = Clearance

C = Head gasket

The thickness of gasket C determines the clearance A, which must be 0.45-0.55 mm for KD 315 with injection pump serial N° 6590-259; it is 0.50-0.60 mm with injection pump serial N° 6590-281.

The clearance is 0.45-0.55 mm for KD 225 in all cases.

The clearance is 0.50-0.60 mm for KD 350-400-440 in all cases.

For the correct thickness of gasket C see table in fig. 49÷50.

There are gaskets with inner diameters oversized by 1 mm for KD 315 and KD 350, required if the cylinders are ground.

47

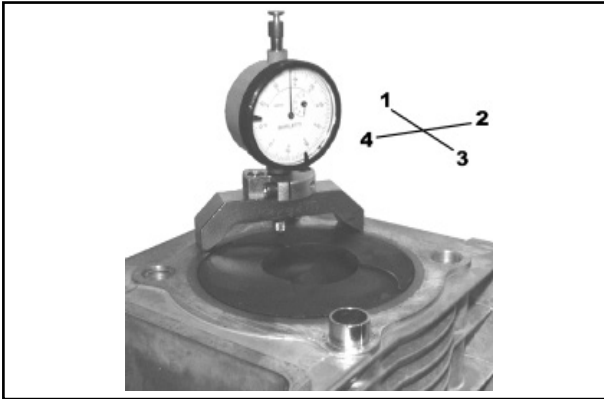

48

**Piston protrusion check**

To calculate the right thickness for the gasket, the protrusion between the piston and the cylinder head surface must be measured. Use a dial indicator with base plate. Reset to zero while resting on a surface plate, then position against the cylinder head base plane as shown in the diagram, so that the dial indicator rod rests against the piston. Now take the reading. Repeat the operation in the other three points (going crosswise) and take the readings. Calculate the average of these four readings to get the precise measurement of the protrusion between the piston and the cylinder head base plane. Choose the appropriate gasket according to the following table.

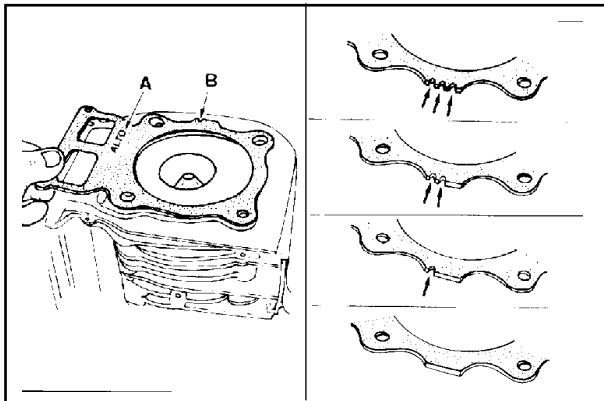

49

50



Only remove the head gasket from its protective wrapping just before assembly.

**See page 26 when tightening the cylinder head**

Having chosen the required thickness, mount the gasket as shown in the figure (see letter A). Find the number of notches in zone B to find the thickness of the gasket when the cylinder head is mounted. The gasket thickness given in the table is the one obtained with the gasket mounted and the head torqued.

**Head gasket (mm)**

For KD 225		
Piston protrusion	Gasket Thickness	Number of notches
0,351÷0,450	0,9	0
0,450÷0,550	1	1 notch
0,550÷0,650	1,1	2 notches
0,650÷0,750	1,2	3 notches
For KD 315 with injection pump P.no 6590.259		
Piston protrusion	Gasket Thickness	Number of notches
0,365÷0,450	0,9	0
0,450÷0,550	1	1 notch
0,550÷0,650	1,1	2 notches
0,650÷0,750	1,2	3 notches
For KD 315 with injection pump P.no 6590.281		
Piston protrusion	Gasket Thickness	Number of notches
0,365÷0,400	0,9	0
0,400÷0,500	1	1 notch
0,500÷0,600	1,1	2 notches
0,600÷0,700	1,2	3 notches

For KD 350		
Piston protrusion	Gasket Thickness	Number of notches
0,365÷0,500	1	0
0,500÷0,600	1,1	1 notch
0,600÷0,700	1,2	2 notches
For KD 400		
Piston protrusion	Gasket Thickness	Number of notches
0,410÷0,500	1	0
0,510÷0,600	1,1	1 notch
0,610÷0,700	1,2	2 notches
For KD 440		
Piston protrusion	Gasket Thickness	Number of notches
0,410÷0,500	1	0
0,510÷0,600	1,1	1 notch
0,610÷0,700	1,2	2 notches

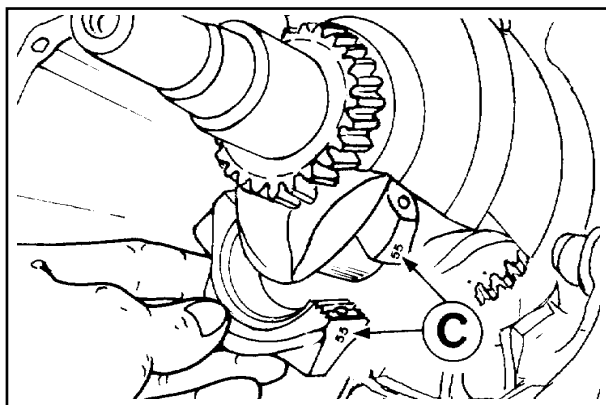

When remounting the big-end bearings, remember to thoroughly clean the parts and generously lubricate them to prevent seizure when the engine is started up for the first time

### Connecting rod

Demount the connecting rod and proceed with the following inspections.

The big-end cap and big-end bear the same numbers.

When remounting, mount the cap from the same side as in **C** of the figure.

Tighten the KD 225 bolts to a 23 Nm torque value.

Tighten the bolts to a 30 Nm torque value for KD 315-350-400-440.

51

### Connecting rod, piston pin

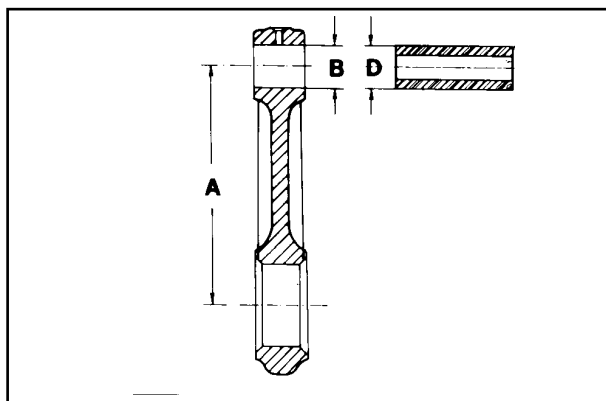

	225	315	350	400-440
A	99,970÷100,03	109,970÷110,03		124,97÷125,03
B	20,010÷20,020		22,010÷22,020	23,010÷23,020
D	19,995÷20,000		21,995÷22,000	22,995÷23,000
(B-D)	Clearance 0,010÷0,025			
(B-D)	Limit 0,05			

**Note:** The connecting rod has no insert bearings. See fig. 62 for connecting rod big end diameter.

52

### Connecting rod alignment

Use a dial gauge as shown in the figure.

Check that axes are aligned using the piston pin; axial misalignment **A** = 0.015; limit 0.03 mm.

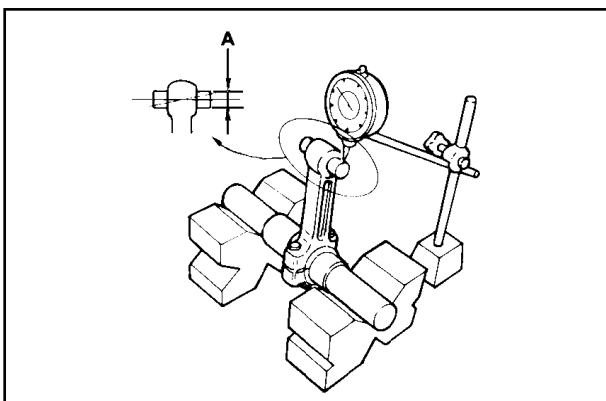

53

### Crankshaft end play

Secure the engine to a metal base or table. Use a dial indicator with column and magnetic base plate. Place the stylus on the crankshaft.

Move the driving shaft back and forth on the flywheel side.

End play should be 0.05 - 0.25 mm; it is not adjustable.

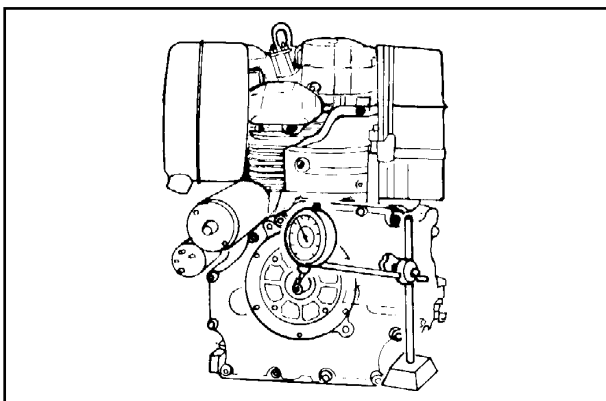

54

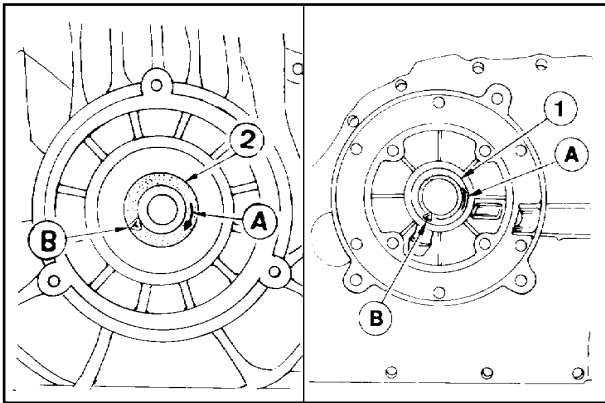

55

56



A warped oil retainer may allow the introduction of air into the engine thus causing crankcase ventilation problems. Use genuine oil retainers with the REHLKO logo (see **B**).

#### Drive shaft oil seals

Oil retainer **1** is located in the gear cover on the timing side while retainer **2** is located in the crankcase on the flywheel side. Arrows point to the crankshaft direction of rotation. Press them into their seats by exerting uniform pressure throughout their front surface.

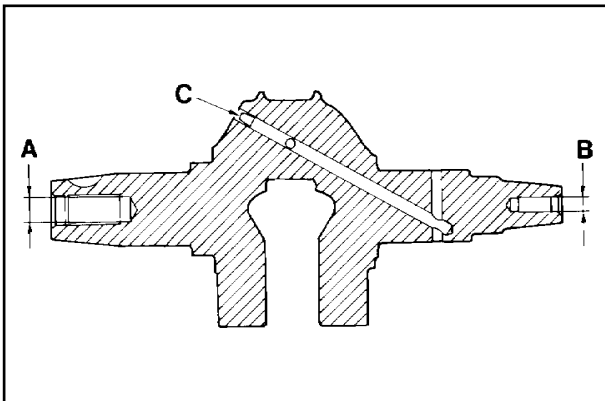

57

#### Drive shaft, lubrication ducts, bore thread on flywheel side and p.t.o.

Remove plug **C** and check that the lubrication duct is perfectly clean. Close with a new plug checking for proper sealing.

**A** = M14x1.5 (turn counterclockwise)

**B** = M8x1.25 (with standard shaft)

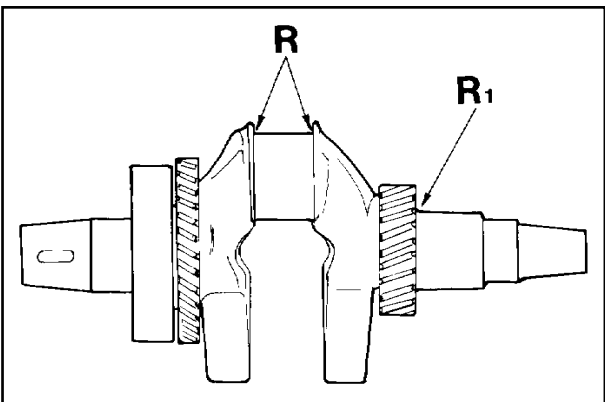

58



When the crankpin and main journal are ground, values **R** and **R<sub>1</sub>** must be obtained again to prevent the drive shaft from breaking.

#### Drive shaft, connection radius

Radius **R** that joins the crankpin to the supports is 2.8-3.2 mm.

Radius **R<sub>1</sub>** that joins the main journal to the timing gear is 0.5 mm.

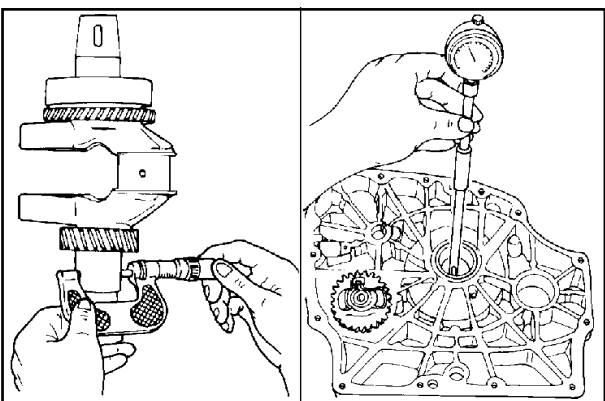

59

60

#### Drive shaft, main journal/crankpin diameter, gear cover bearing inside diameter on timing side

Use an outside micrometer for the main journal and an inside bore gauge for the gear cover bearing on the timing side.

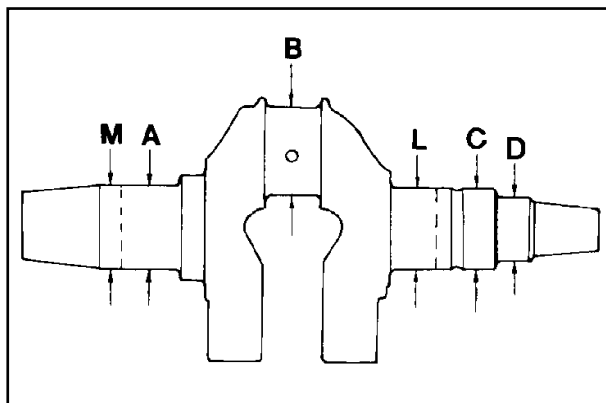

61

Crankshaft - journal diameter (mm)

	225	315-350	400-440
M oil seal working area	34,959÷34,975	34,959÷34,975	39,959÷39,975
A	35,002÷35,013	35,002÷35,013	40,002÷40,013
B	33,984÷34,000	37,984÷38,000	39,984÷40,000
L	35,240÷35,256	35,240÷35,256	40,240÷40,256
C	34,984÷35,000	34,984÷35,000	39,984÷40,000
D oil seal working area	27,967÷28,000	27,967÷28,000	29,967÷30,000

The undersizes for the crankpin and main journal are 0.25, 0.50 and 1 mm.

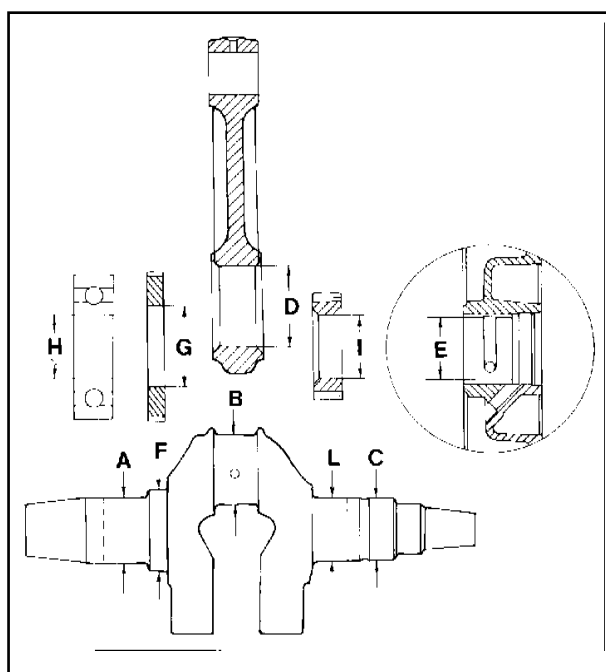

62



The gears must be mounted with the right tools so that they can be correctly timed.

The gears should not therefore be demounted.

Only the complete shaft is available as a spare.

**Drive shaft - Main bearing inside diameter, connecting rod big end, crankshaft bearing and timing control gear and balancer - Clearance and interference between the corresponding journals**

Dimensions (mm) (see also fig. 61)

	225	315-350	400-440
D	34,030÷34,046	38,030÷38,046	40,030÷40,046
E	35,030÷35,050	35,030÷35,050	40,030÷40,050
G	45,000÷45,016	45,000÷45,016	53,000÷53,019
H	34,988÷35,000	34,988÷35,000 35,184÷35,200	39,988÷40,000
I	35,200÷35,216	35,200÷35,216	40,200÷40,216

Clearance (mm)

	225	315-350	400-440
(D-B)	0,03÷0,062	0,030÷0,062	0,0300,062
(D-B) Limit	0,120	0,120	0,120
(E-C)	0,03÷0,066	0,030÷0,066	0,0300,066

Interference (mm)

	225	315-350	400-440
(A-H)	0,002÷0,025	0,002÷0,024	0,002÷0,024
(F-G)	0,015÷0,056	0,015÷0,056	0,015÷0,056
(L-D)	0,024÷0,056	0,024÷0,056	0,024÷0,056

### Availability of bearings

Main bearings are available at their nominal value or undersized 0.25, 0.50 and 1.0 mm.

Connecting rods are available with big end at nominal value or undersized 0.25 and 0.50 mm.

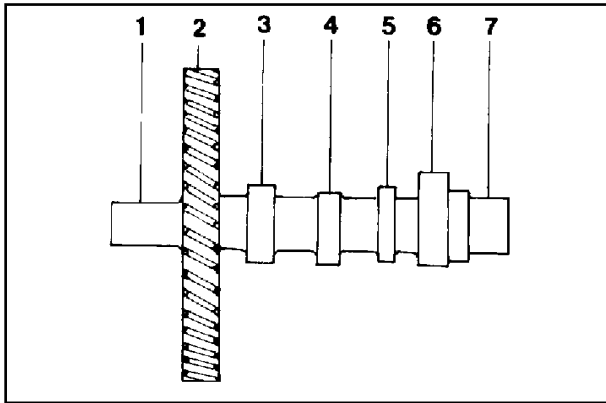
**Camshaft**

Components:

- 1 Journal, gear cover on timing side
- 2 Gear
- 3 Exhaust lobe
- 4 Injection lobe
- 5 Fuel pump eccentric
- 6 Intake lobe
- 7 Journal, crankcase side

63

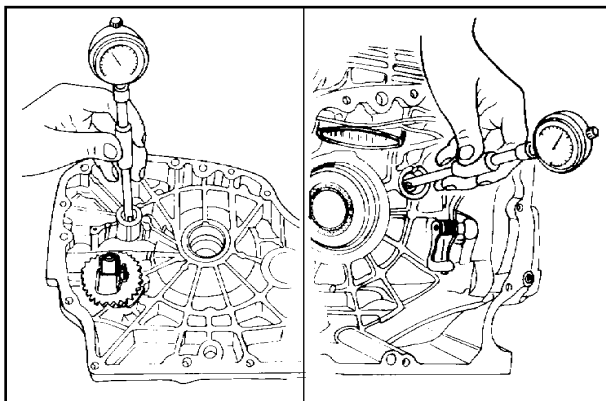
**Camshaft journals and bore**

Use a comparator for interiors

64

65

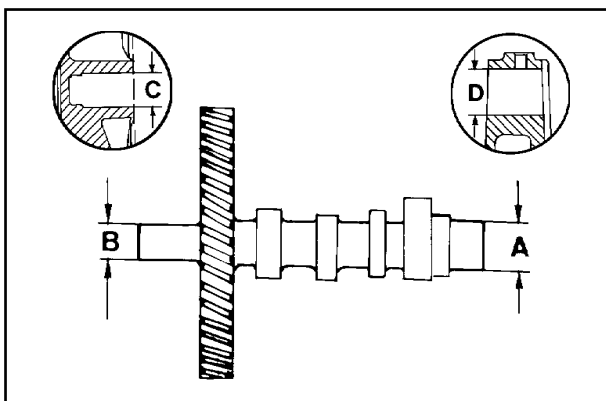
**Dimensions of camshaft journals and bore (mm)**

	225	315-350	400-440
A	19,459÷19,474	21,959÷21,980	17,966÷17,984
B	15,957÷15,984		
C	16,000÷16,018		
D	19,500÷19,521	22,000÷22,021	18,00÷18,018
(D-A)	0,026÷0,062	0,020÷0,062	0,016÷0,052
(D-A) Limit	0,120		0,100
(C-B)	0,016÷0,061		
(C-B) Limit	0,120		

66

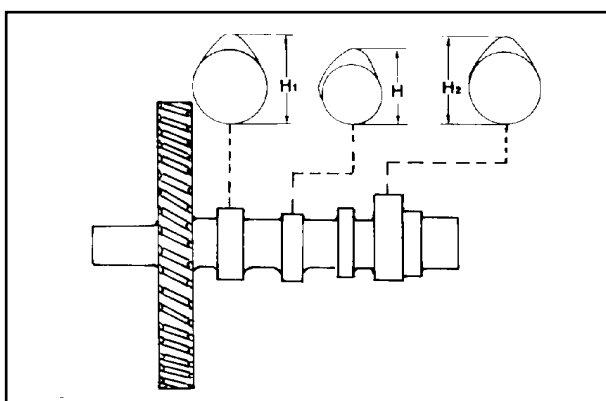
**Cam height (mm)**

	225	315-350	350 EPA	400-440
H	30,25÷30,30	30,25÷30,30	31,95÷32,00	32,00÷32,05
H <sub>1</sub>	35,75÷35,80	35,75÷35,80	35,75÷35,80	36,10÷36,15
H <sub>2</sub>	33,65÷33,70	35,05÷35,10	33,65÷33,70	35,10÷35,15

**Note:** Replace camshaft if cam wear exceeds the minimum given value of H, H<sub>1</sub> and H<sub>2</sub> by 0.1 mm.

67

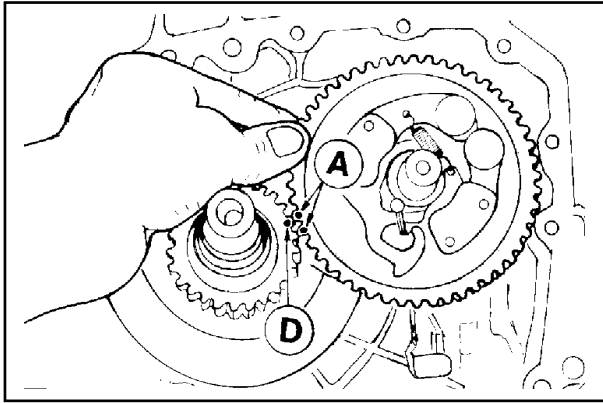

### Camshaft timing

Fit camshaft by aligning marks 'A' with mark 'D' on the crankshaft.

68

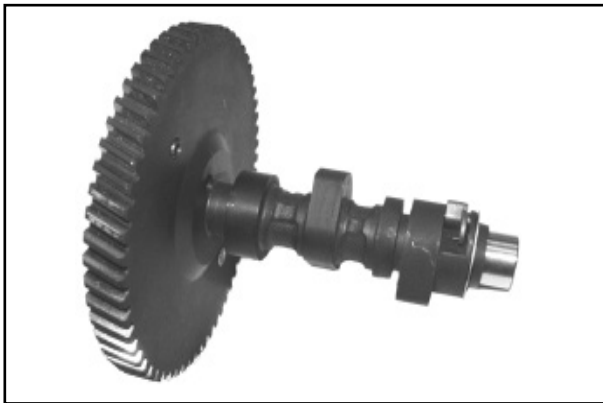

### Camshaft – Antireverse system KD 400-440

it consists of a device on the camshaft which lifts the intake valve in case of a startup in reverse direction with respect to normal rotation.

68a



During normal operation, the tappet overcomes the spring resistance while passing on the system and decompression does not operate.

68b

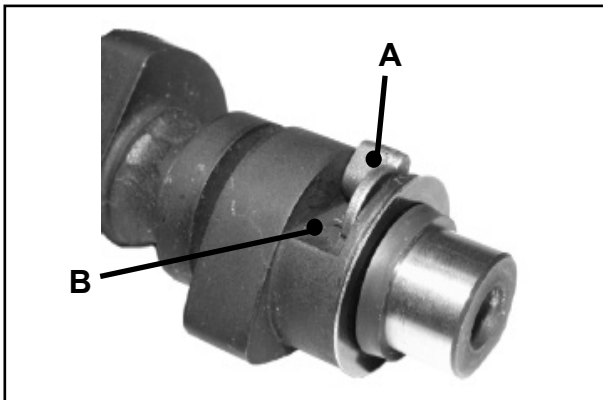

In case of a startup in reverse direction, the antireverse system lifts the valve as the tappet passes by. Startup is thus inhibited.

Note: Check the antireverse system for wear, and make sure it is kept in the rest position by the return spring, as shown in picture 68c. Verify that in this condition the clearance between weight A and surface B is 1 mm.

68c

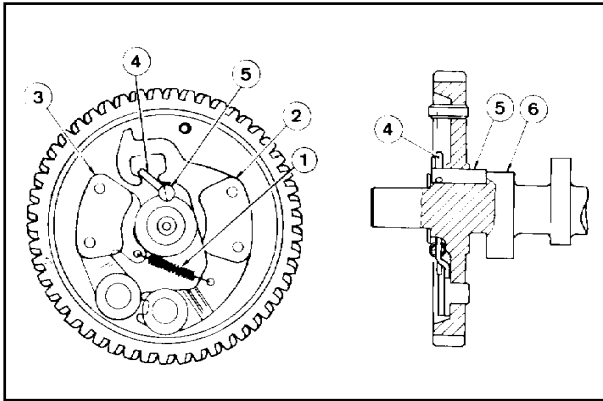

69

70

### Automatic decompression

With the engine at a standstill and up to a rate of about 300 RPM, spring 1, acting on weights 2 and 3 via lever 4 and pin 5, keeps the exhaust valve open during the compression phase also.

Once the engine exceeds the 300 RPM rate, weights 1 and 2 keep pin 5 in the hold position owing to the action of the centrifugal force. In this position, cam 6 can regularly control the exhaust valve thanks to a ridge on the pin itself.

Since there is then no compression in the cylinder, the engine will easily start when the self-winder is used.

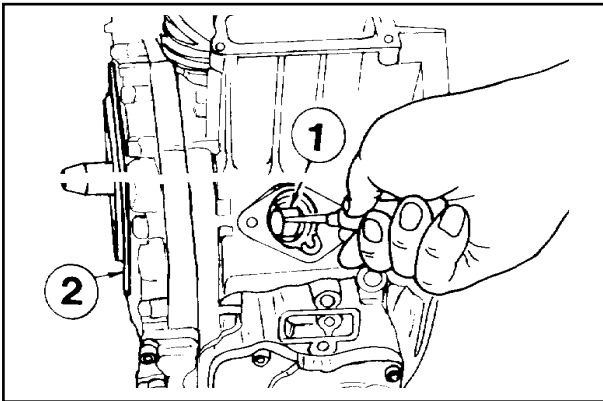

71

### Camshaft end play

Perform this check before fitting cylinder head and tappets including the injection tappets.

Temporarily fit camshaft 1 complete with washer; tighten gear cover 2 to 25 Nm.

Check end play by moving the camshaft back and forth using a suitable tool; the end play value is  $0.10 \pm 0.25$  mm and is not adjustable.

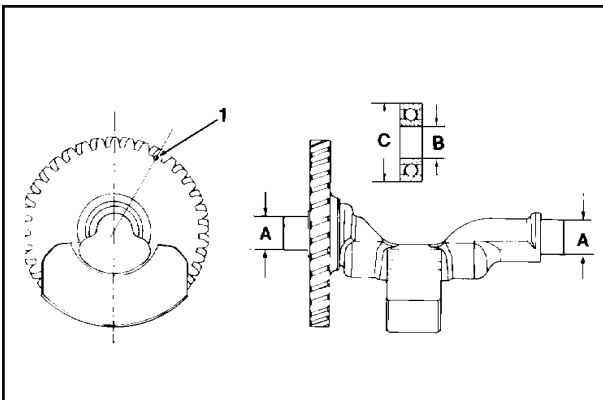

72

### Dynamic balancer (on request)

The dynamic balancer is supported by two identical ball bearings housed in the crankcase and in the gear cover on the timing side respectively.

1 is the reference point for timing with the crankshaft gear (see below).

Dimensions (mm):

**A** = 14.983-14.994

**B** = 14.99-15.00

**C** = 34.89-35.00

**D** = 34.958-34.983 (bearing housing diameter on crankcase and gear cover on timing side).



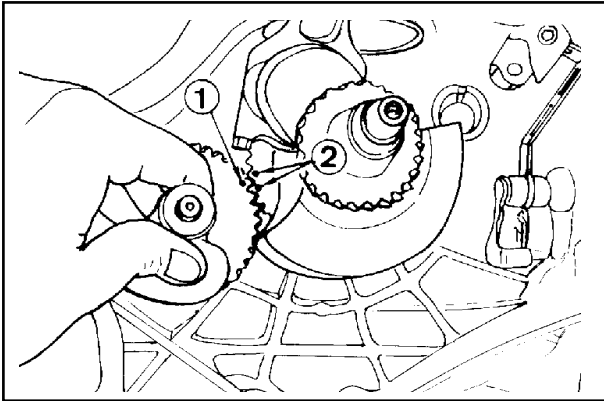

73

### Dynamic balancer timing

Position crankshaft as shown in the figure. Introduce the dynamic balancer so that timing mark 1 engages between teeth 2 of the crankshaft gear.

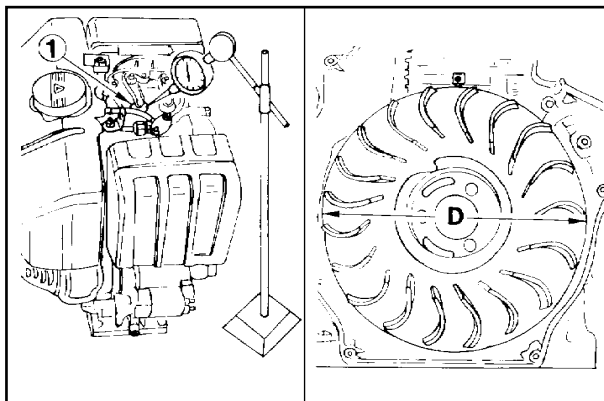

74

75

### Valve timing check

Remove the tank and conveyor to access the flywheel. Carry out the inspections on the drive shaft. The values given are measured on the circumference of the flywheel. Adjust the valve play as indicated on the next page. Reset the comparator on the cap of intake valve 1. Turn the drive shaft in the spinning direction and find  $\alpha$  (point at which the intake valve starts to open in relation to top dead center **A**) and  $\beta$  (point at which the intake valve shuts after bottom dead center **B**) see fig. 77-78.

Proceed in a similar way with the exhaust valve, checking  $\gamma$  (point at which the exhaust valve opens) and  $\delta$  (point at which the exhaust valve shuts).

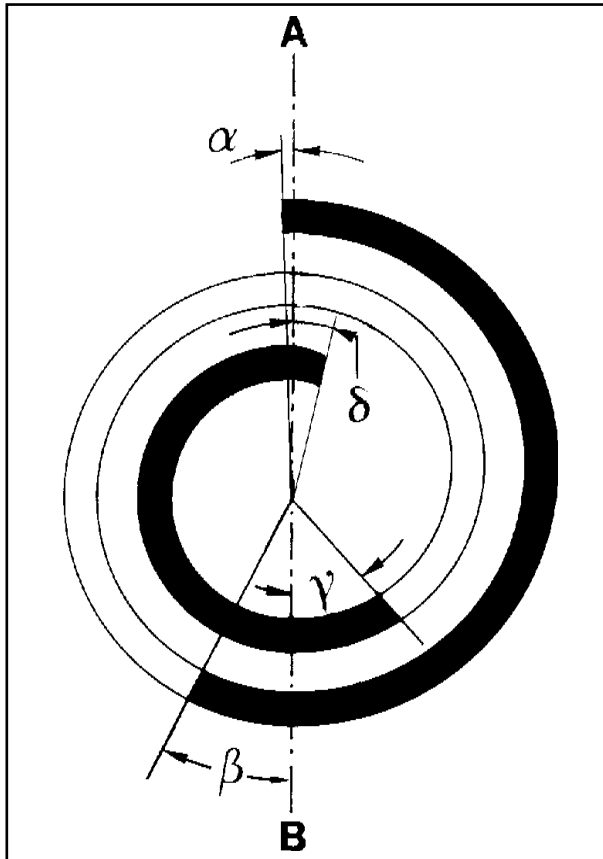

Timing angles for operation (0.15 valve play).

## For KD 225

$\alpha = 6^\circ$  before **A** corresponding to 12 mm

$\beta = 22^\circ$  after **B** corresponding to 44 mm

$\gamma = 58^\circ$  before **B** corresponding to 116 mm

$\delta = 10^\circ$  after **A** corresponding to 20 mm.

Values measured on the circumference of the flywheel  $D = 230$  (one degree corresponds to 2 mm).

## For KD 315 - 350

$\alpha = 10^\circ$  before **A** corresponding to 20.09 mm

$\beta = 42^\circ$  after **B** corresponding to 87.78 mm

$\gamma = 58^\circ$  before **B** corresponding to 121.22 mm

$\delta = 10^\circ$  after **A** corresponding to 20.9 mm.

Values measured on the circumference of the flywheel  $D = 240$  (one degree corresponds to 2.09 mm).

77

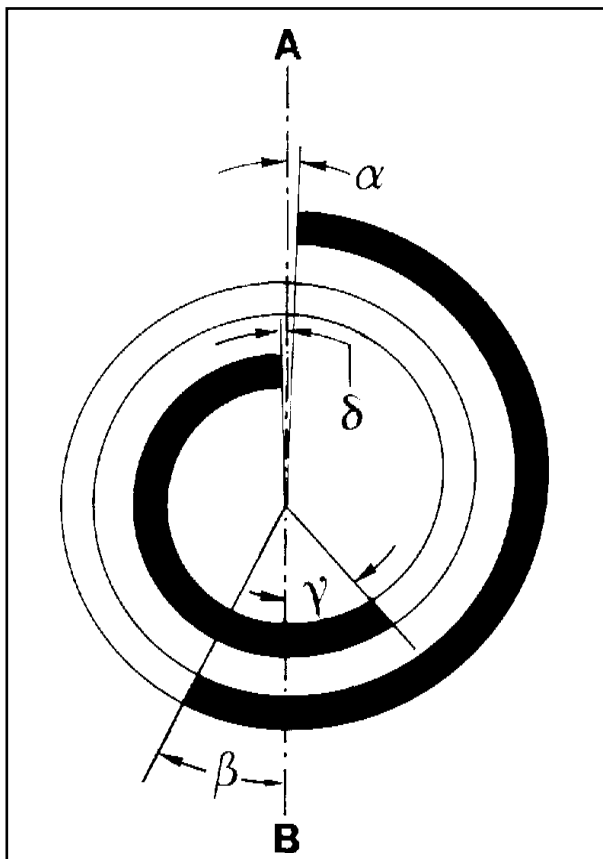

Timing angles for inspection (0.65-0.70 valve play).

## For KD 225

$\alpha = 7^\circ$  after **A** corresponding to 14 mm

$\beta = 9^\circ$  after **B** corresponding to 18 mm

$\gamma = 45^\circ$  before **B** corresponding to 90 mm

$\delta = 3^\circ$  before **A** corresponding to 6 mm.

Values measured on the circumference of the flywheel  $D = 230$  (one degree corresponds to 2 mm).

## For KD 315 - 350

$\alpha = 1^\circ$  after **A** corresponding to 2.09 mm

$\beta = 31^\circ$  after **B** corresponding to 64.79 mm

$\gamma = 45^\circ$  before **B** corresponding to 94.05 mm

$\delta = 3^\circ$  before **A** corresponding to 6.27 mm.

Values measured on the circumference of the flywheel  $D = 240$  (one degree corresponds to 2.09 mm).

78

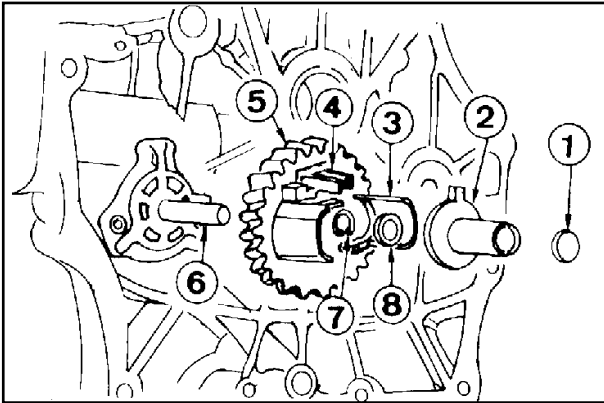

79

### Speed governor

Components:

- 1 Spool spacer
- 2 Spool
- 3 Weights
- 4 Spool guide
- 5 Gear
- 6 Oil pump driving shaft
- 7 Circlip
- 8 Thrust ring

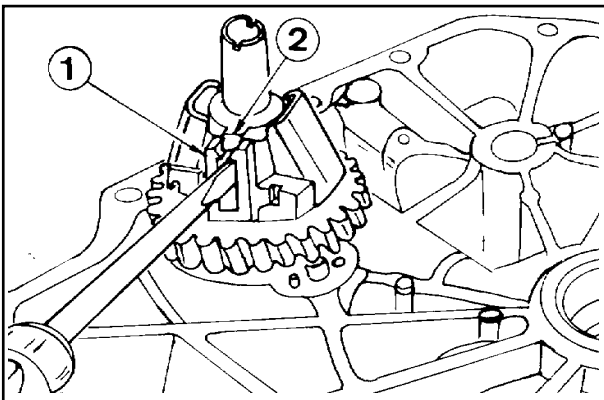

80

### Speed governor removal

Spool guide 1 has retainers one end which prevent spool 2 from slipping out.

To remove the speed governor use a suitable tool to slightly widen the two teeth.

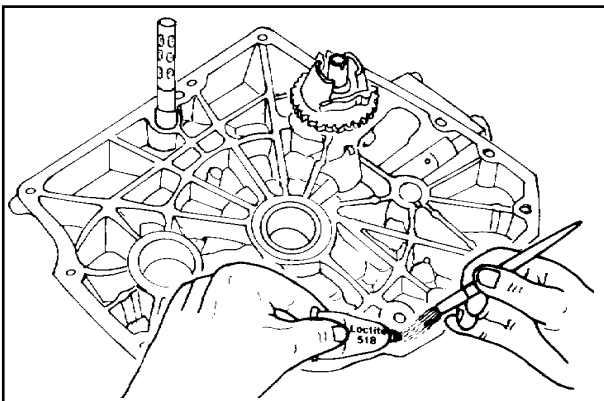

81

### Refitting gear cover on timing side

Proper sealing between gear cover and crankcase is ensured by the liquid sealant "Loctite 5205". Carefully clean the two sealing surfaces and spread the sealant uniformly.

Tighten screws to 23 Nm.



Wait 3 hours before starting the engine.

**!** The engine can be damaged if allowed to operate with insufficient oil. It is also dangerous to add too much oil because its combustion may lead to a sharp increase in the rotation speed.

Use suitable oil in order to protect the engine.

Nothing more than lubrication oil can influence the performances and life of an engine.

Use of an inferior quality oil or failure to regularly change the oil will increase the risk of piston seizure, will cause the piston rings to jam and will lead to rapid wear on the cylinder liner, the bearings and all other moving parts. Engine life will also be notably reduced.

The oil viscosity must suit the ambient temperature in which the engine operates.

**!** Old engine oil can cause skin cancer if repeatedly left in contact with the skin and for long periods of time. Wear protective gloves to avoid touching used oil. If contact with the oil is unavoidable, you are advised to wash your hands with soap and water as soon as possible. Dispose of old oil in the correct way as it is highly polluting.

### KD 225 - 315 - 350 LUBRICATION SYSTEM AND BREATHER RECIRCULATION SYSTEM

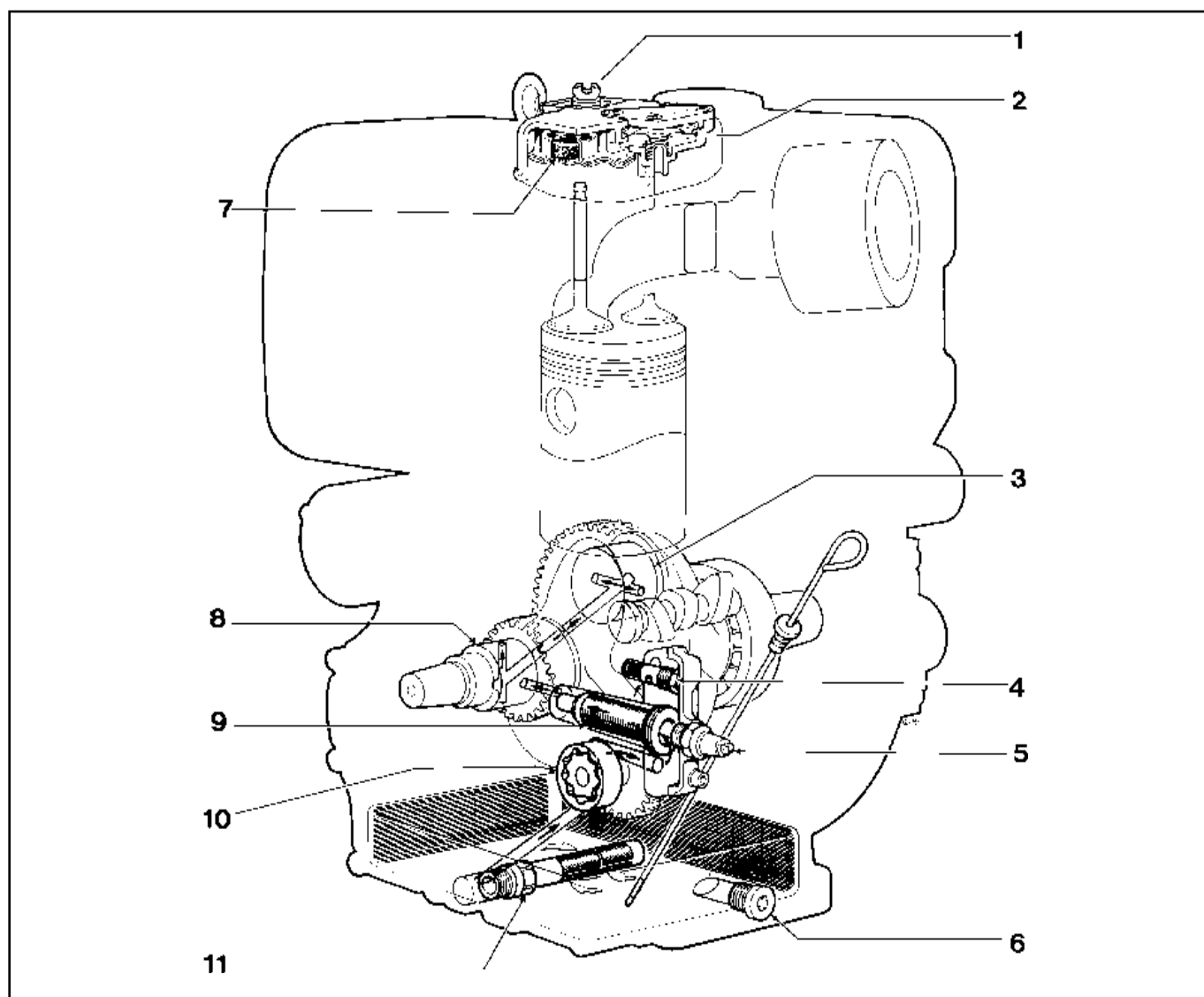

82

Components:

- |                           |                         |                       |
|---------------------------|-------------------------|-----------------------|
| 1) Oil fill cap           | 6) Oil drain plug       | 11) Oil intake filter |
| 2) Safety valve           | 7) Metal filter element |                       |
| 3) Rod journal            | 8) Main journal         |                       |
| 4) Pressure control valve | 9) Oil filter           |                       |
| 5) Pressure switch        | 10) Oil pump            |                       |

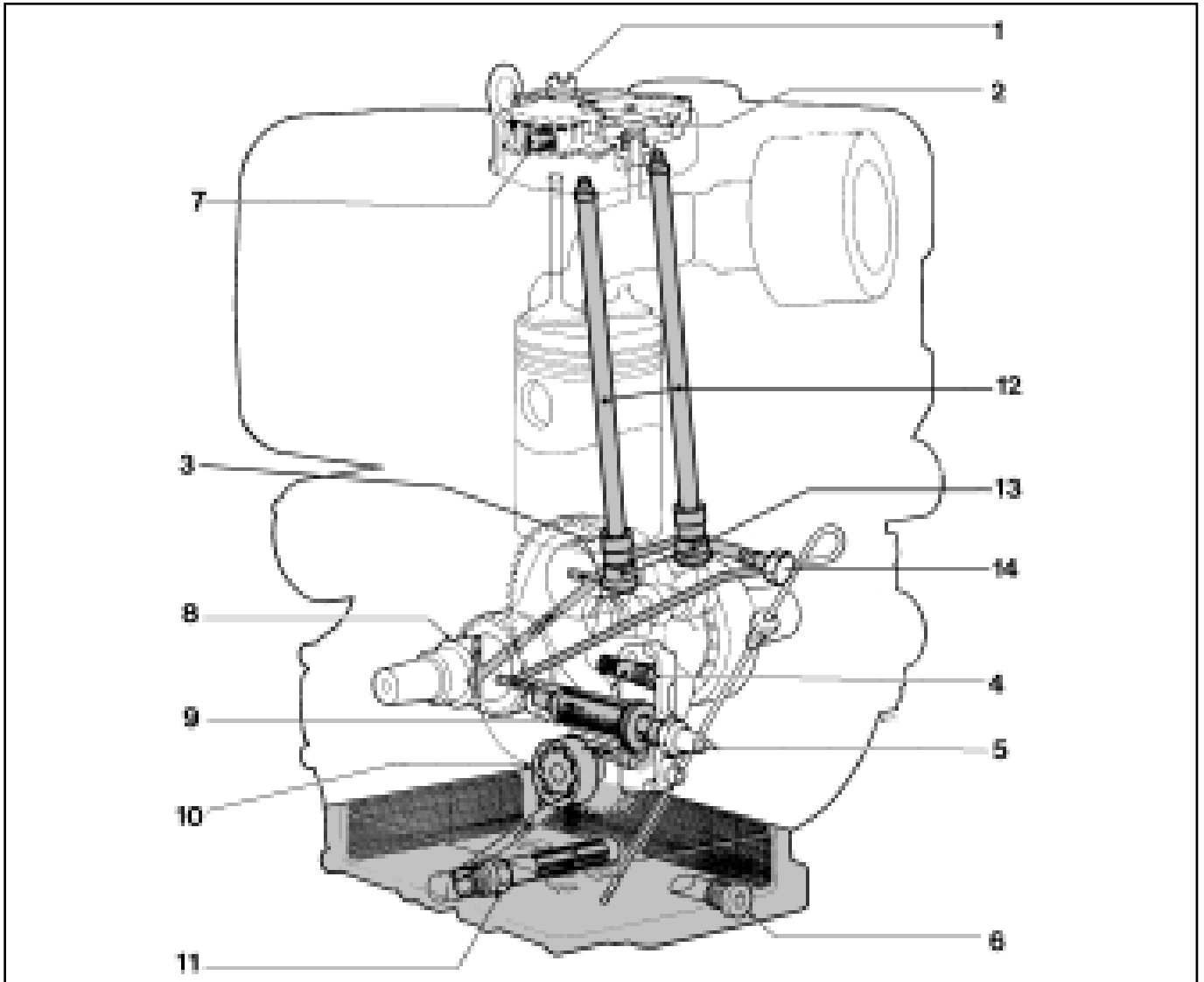
**KD 400-440 LUBRICATION SYSTEM AND BREATHER RECIRCULATION SYSTEM**

83

Components:

- |                           |                         |                       |
|---------------------------|-------------------------|-----------------------|
| 1) Oil fill cap           | 6) Oil drain plug       | 11) Oil intake filter |
| 2) Safety valve           | 7) Metal filter element | 12) Pushrods          |
| 3) Rod journal            | 8) Main journal         | 13) Hydraulic tappets |
| 4) Pressure control valve | 9) Oil filter           | 14) Calibrated union  |
| 5) Pressure switch        | 10) Oil pump            |                       |

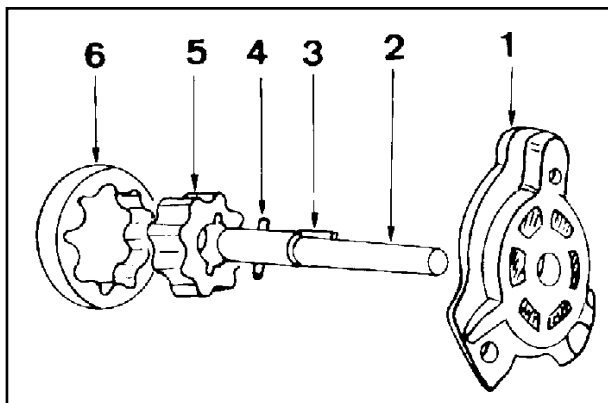
**Oil pump**

Components:

- 1 Cover
- 2 Shaft
- 3 Key
- 4 Pin
- 5 Internal rotor
- 6 External rotor

Oil pump delivery at 3000 rpm is 5.8 l/min.

84

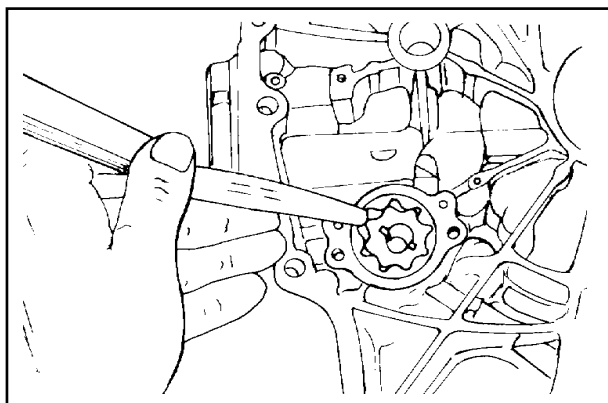
**Oil pump - Clearance between rotors**

Measure clearance as shown in the figure; the max. value is 0.13 mm; wear limit 0.25 mm.

85

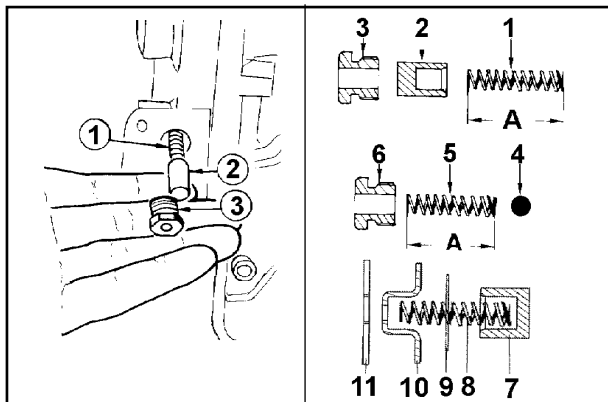
**Oil pressure regulation valve****Components for KD 315 and KD 350:**

- 1 Spring
  - 2 Valve
  - 3 Plug
- Free length **A** of the spring is 27.50-27.75 mm.

**Components for KD 225:**

- 4 Ball
  - 5 Spring
  - 6 Plug
- Free length **A** of the spring is 23.50-24.50 mm.

**Components for KD 400-440:**

- 7 Plunger
  - 8 Spring
  - 9 Washer
  - 10 Cup
  - 11 Snap ring
- Free length **A** of the spring is 25,50÷25,75 mm.

86

87

Note: If **A** is 1 mm less than the given value, replace the valve.  
Valve setting is not adjustable.

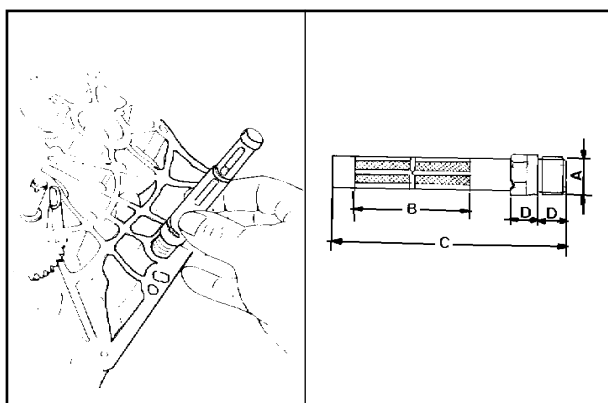
**Internal strainer**

The oil pick-up strainer is made of nylon 66. Its degree of filtration is 500 µm.

Dimensions (mm):

- A** = M16x1.5
- B** = 64
- C** = 102
- D** = 12

88

89

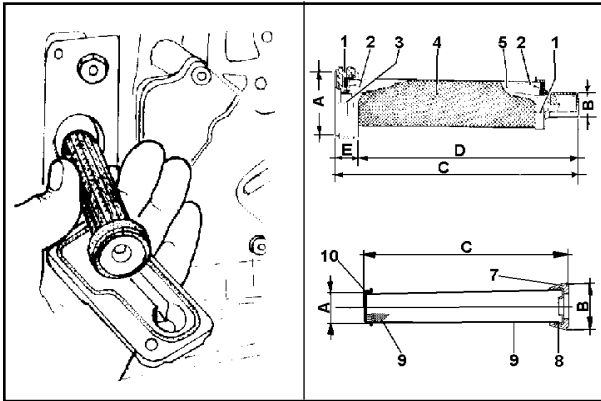
**90**
**91**
**Oil filter**

 Filter components: **KD 315/350**

- 1** Seal
- 2** Adhesive
- 3** End cap
- 4** Filtering material
- 5** Plate

 Dimension mm: **A = 26.5 B = 18 C = 88.5 D = 67.5 E = 8.5**

Characteristics:

 Useful filtering area = 75 cm<sup>2</sup>

Degree of filtration = 50 µm.

The by-pass valve is set at 0.6-0.8 bar.

 Filter components: **KD 225**

- 7** Rubber pad
- 8** Upper cover
- 9** Filter element
- 10** Lower cover

 Dimension mm: **A = 19.0-19.3 B = 12.5 C = 83.0-83.5**

Characteristics:

 Useful filtering area ≥ 75 cm<sup>2</sup>

Degree of filtration = 40-60 µm.

See page 18 for the replacement frequencies.

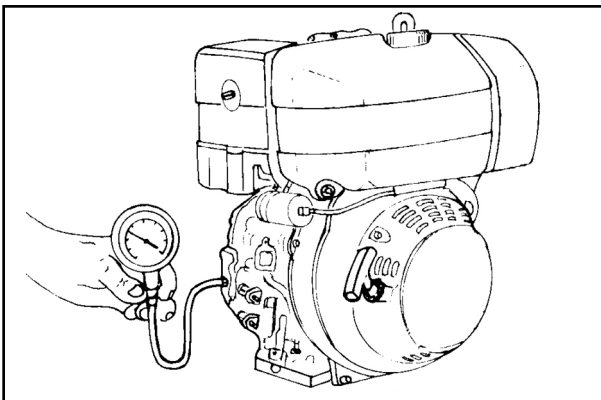
**92**
**Oil pressure check**

When assembly operations are completed fill engine with oil and fuel; connect a 10 bar pressure gauge to the oil filter fitting.

Start the engine and check pressure as a function of the oil temperature (see below).

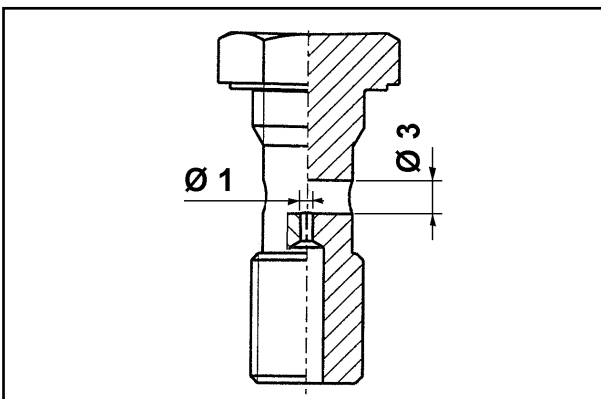
**93**
**Calibrated pipe for lubrication of hydraulic tappets**

The pipe is fitted to the hydraulic tappets oil line (see fig. 83, detail 11).

If the calibrated hole is clogged, the tappets are not sufficiently lubricated, valve clearance is therefore increased and the engine may be noisier.

If the diameter of the calibrated pipe is larger than the ones given in picture 93, the pressure exerted by the hydraulic tappets may cause the valves to remain open even during the compression phase.

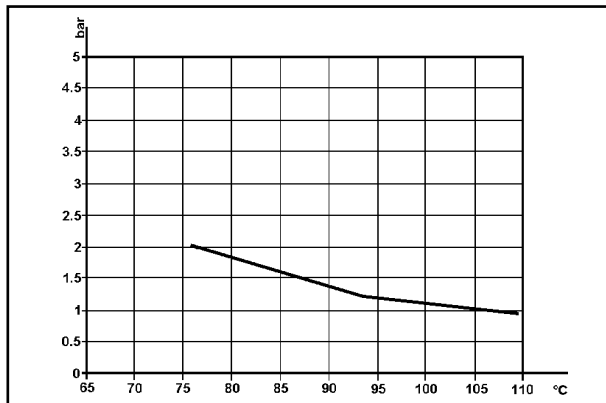

#### Oil pressure curve at idle speed

The curve is obtained at the oil filter port with engine running at a constant speed of 1200 r.p.m. in no-load conditions; pressure is given in bar and temperature in centigrades.

The curve represents the minimum pressure value while the maximum value is 5 bar.

94

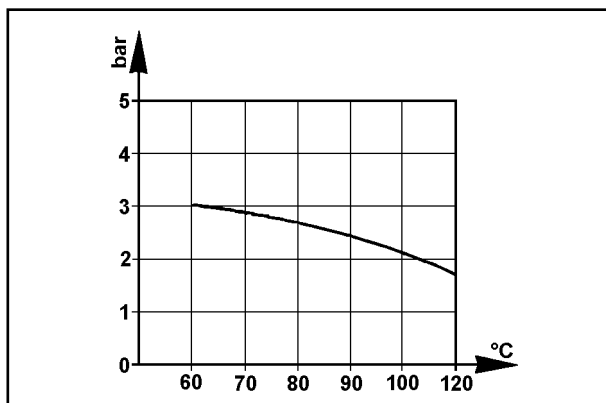

#### Oil pressure curve at full speed

The curve is obtained at the oil filter port with engine running at 3000 r.p.m. at the **N** power; pressure is given in bar and temperature in centigrades.

The curve represents the minimum pressure value while the maximum value is 5 bar.

**Note:** After the running-in period the lube max. temperature should be less than the room temperature +95°C.

95

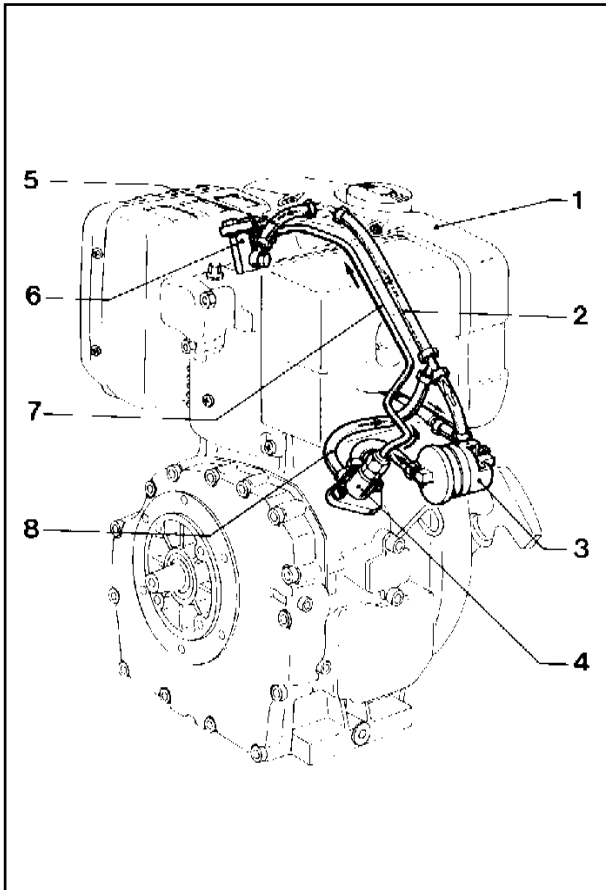
**Fuelling/injection circuit for KD 315-350-400-440**

Components:

- 1 Tank
- 2 Return tube
- 3 Fuel filter
- 4 Injection pump
- 5 Injector leak-off line
- 6 Injector
- 7 High pressure line
- 8 Return tube

96

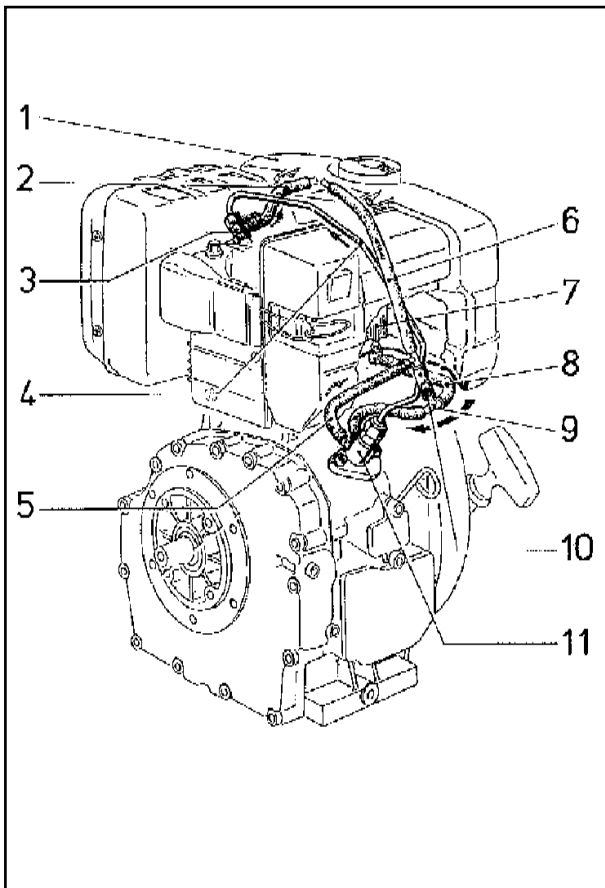
**Fuelling/injection circuit for KD 225**

- 1 Tank
- 2 Injector leak-off line
- 3 Injector
- 4 High pressure line
- 5 Return tube
- 6 Return tube
- 7 Diesel fuel filter
- 8 Fuel pipe
- 9 T-connector
- 10 Reduction
- 11 Injection pump

97

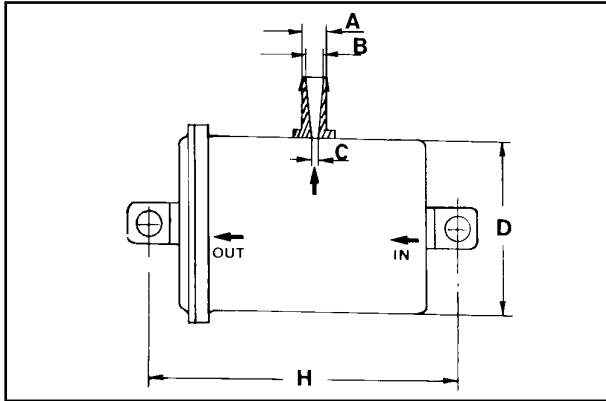

Fuel filter KD 225-315-350-400-440

- A = 7.3
- B = 3.8
- C = 1.5
- D = 42
- H = 75

Characteristics:  
 Filtering area  $\geq 390 \text{ cm}^2$   
 Filtration level  $\leq 7 \mu\text{m}$   
 See page 18 for fuel filter replacement

98

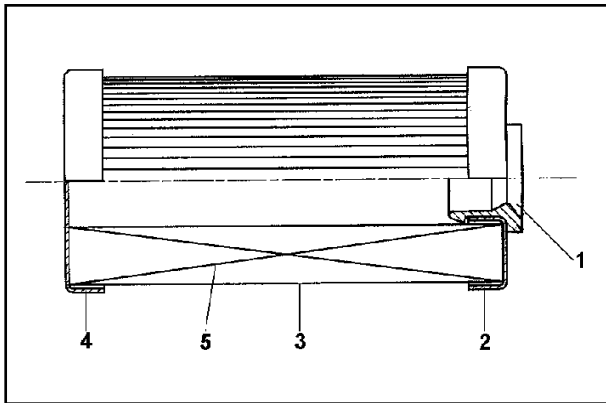

Fuel filter KD 225 (version with internal filter in tank)

- 1 Rubber retention ring
- 2 PRV cover
- 3 SCP radial unit
- 4 PRV cover
- 5 Segment

Characteristics:  
 Filtering area  $215 \text{ cm}^2$   
 Filtration level  $7 \mu\text{m}$   
 See page 18 for fuel filter replacement

99

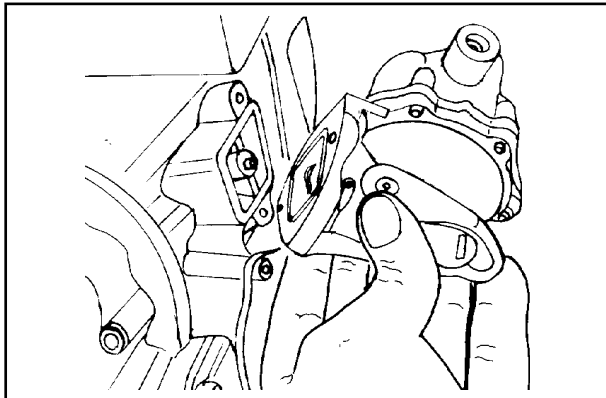

Feed pump (optional)

A feed pump is usually requested when the tank is not supplied in conjunction with the engine.  
 The pump is the diaphragm type and is operated by a camshaft eccentric through a drive rod.  
 Tighten screws to 15 Nm.

Characteristics: At 2000 rpm of the camshaft, the minimum delivery is 40 l/h, while the automatic adjustment pressure is  $0.5 \div 0.7 \text{ bars}$ .

100

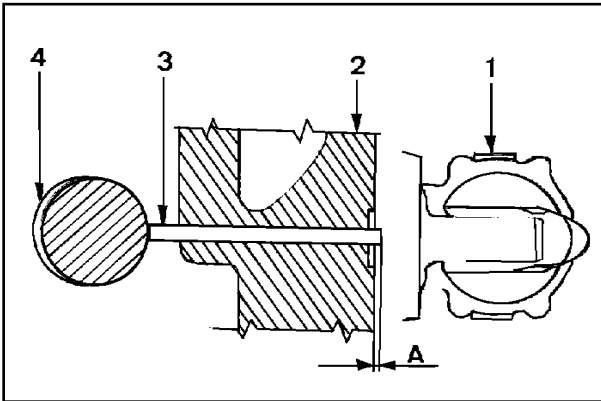
**101**
**Fuel pump, drive rod protrusion**

Components:

- 1 Fuel pump
- 2 Crankcase
- 3 Drive rod
- 4 Eccentric

Check while eccentric 4 is at rest (lowest point of travel).  
 Protrusion A of drive rod 3 is 1.5-1.9 mm; it is not adjustable.  
 Drive rod length = 58-58.2 mm for KD 225  
 Drive rod length = 65.8-66.0 mm for KD 315/350  
 Drive rod length = 61,4±61,6 mm for KD 400/440

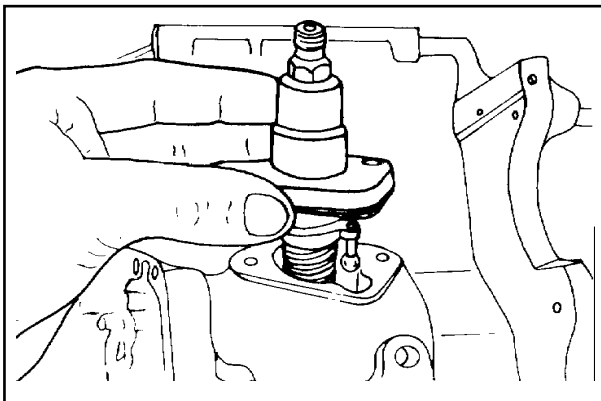

**102**
**Injection pump**

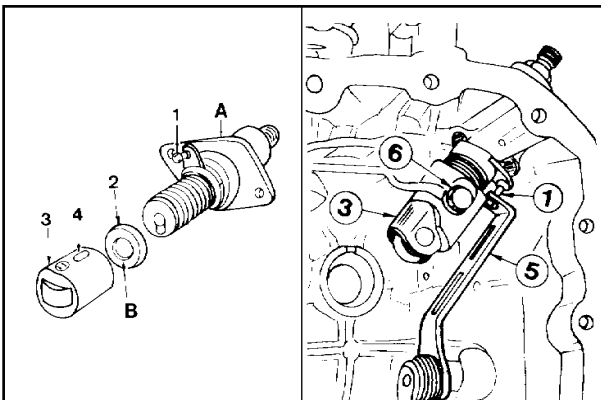
This is of the simplified QLC type; it is housed in the crankcase and is controlled by the camshaft via tappets.

**103**
**104**
**Injection pump fitting in the crankcase**

Fit tappets 3 so that screw 6 is introduced into guide 4.  
 Tighten screw 6 to 9 Nm and check that the tappet is free to move downwards.  
 Fit pad 2 into the tappet so that recess B points downwards as shown in the figure.  
 Fit the injection pump into the crankcase complete with gasket (C) position 8ing flow control 1 in the fork of lever 5 which should be in the maximum flow position.

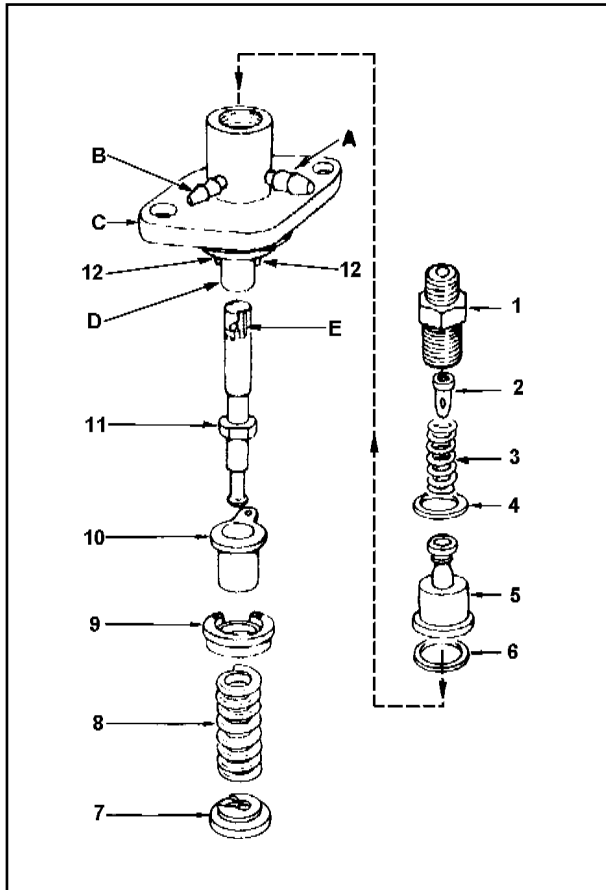
When removing the injection pump from its housing make sure that spacer 2 is not dropped into the oil sump; injection pump operation will be impaired if the spacer is not installed.



**Injection pump components and disassembly**

- 1 Delivery union
- 2 Filler
- 3 Spring
- 4 Gasket
- 5 Valve
- 6 Gasket
- 7 Spring retainer
- 8 Spring
- 9 Spring plate
- 10 Rack
- 11 Plunger
- 12 Pin

- A = Fuel outlet union
- B = Fuel intake union
- C = Fastening
- D = Barrel
- E = RH helix

Demount in compliance with the numeric order.

Plate 9 is held firm by pins 12. Lever up by inserting a tool between the plate and the body of the pump.

The volume shifted by delivery valve 5 is 15 mm<sup>3</sup> in the pump of KD 315-350 and 25 mm<sup>3</sup> in the pump of KD 225 is 21 mm<sup>3</sup> in the pump of KD 400/440

105

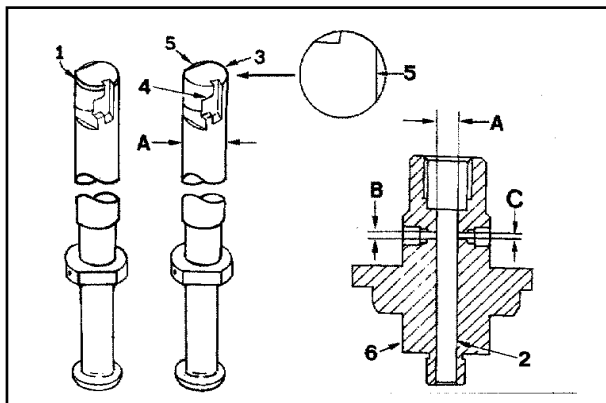

**Injection pump, body, plunger and delivery valve**

- Components:
- 1 Delivery valve
  - 2 Barrel
  - 3 Plunger
  - 4 Right helix
  - 5 Delay notch
  - 6 Pump body
  - 7 Collar

- Dimensions mm:
- A = 5.50 (nominal diam.) 225-315-350
  - A = 7,00 (nominal diam.) 400-440
  - A = 6,00 (nominal diam.) 315-350 EPA
  - B = 2.00 / 2.03
  - C = 1.50 / 1.53

**Note:** The injection pump installed in engines for small vehicles, soundproof generating sets, EPA and KD 400-440 engines, are characterised by the inclusion of a collar 1 which contributes to noise-reduction.

106

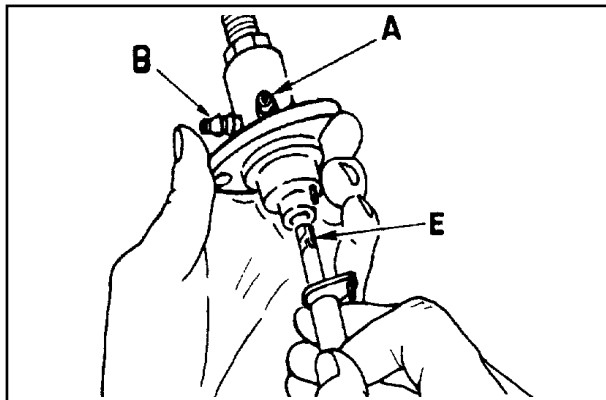

**Injection pump refitting**

The plunger is fitted with helix E facing towards the outlet union A; if it is mistakenly fitted with the helix facing the intake coupling B the injection pump no longer operates (there is no danger of engine runaway); complete refitting following fig. 107.

107

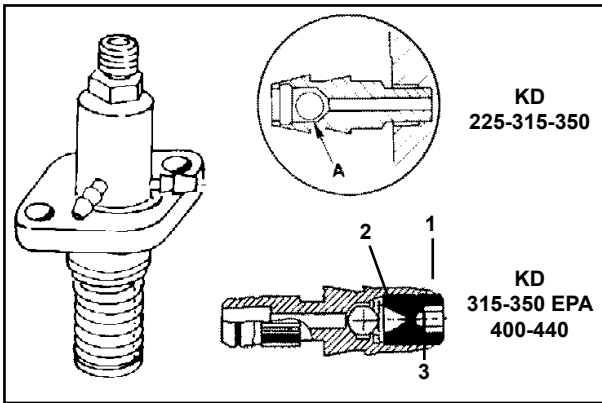
**108**
**Injection pump non-return valve**

The exhaust union has a non-return valve **A**. The purpose of this valve is to improve the injection phase by expelling the air in the fuel and preventing it from being sucked in by the pump during the intake phase. This also ensures that the engine stops promptly as soon as the stopping device is activated by means of the solenoid valve.

**Outlet fitting components for 315-350 EPA E 400-440 engines**

- 1) Outlet fitting
- 2) Ball Ø1/8"
- 3) Threaded dowel

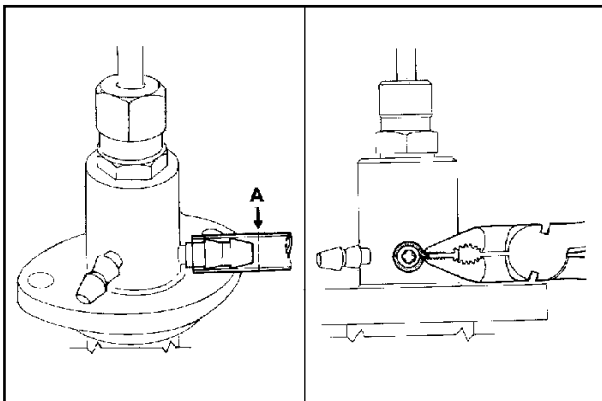
**109**
**110**



Do not cut the tube longitudinally because you might damage the union.

**Injection pump, Rilsan tube removal**

Cut nylon tube at **A**.

Remove the portion of the tube which is still connected to the union using common pliers. Pinch the nylon tube without impairing the sealing properties of union (see figure).

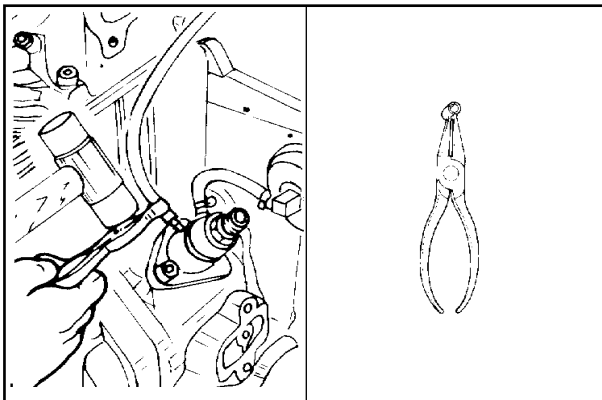
Re-cycle the same feeding tube if the remaining length allows it; replace if not.

**111**
**112**
**Injection pump, Rilsan tube refitting**

The outlet tube is made of nylon type Rilsan; it is connected to the suitable injection pump union by means of special pliers (Ser.No. 7104-1460-023) and a plastic-head hammer (see figure).

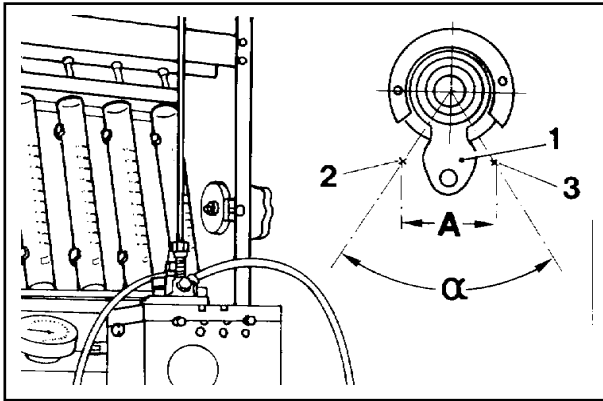

**Injection pump delivery check on test bench**

- 1 Delivery control rack rod
- 2 Rack rod 1 in stop position
- 3 Rack rod 1 in max. delivery position
- A = 18-19 mm (max.rack rod stroke)
- $\alpha = 66^\circ$

113

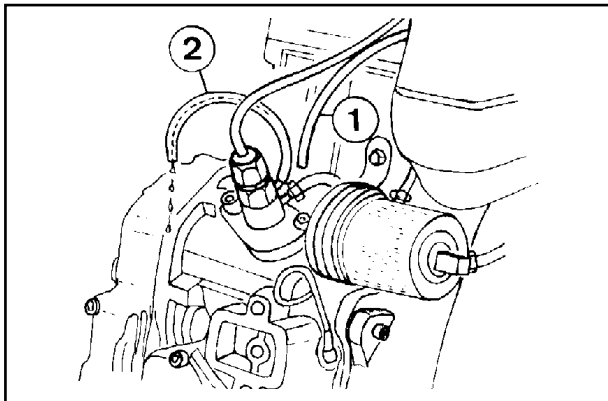

**Static injection timing**

Disconnect pipe 1 from injection pump and close it, to avoid fuel leakages.  
Mount in its place a nylon pipe 2 as shown in the picture. Insert in this pipe an iron wire and let it project by approximately 10 mm: in this way any drop in fuel can easily be checked.

114

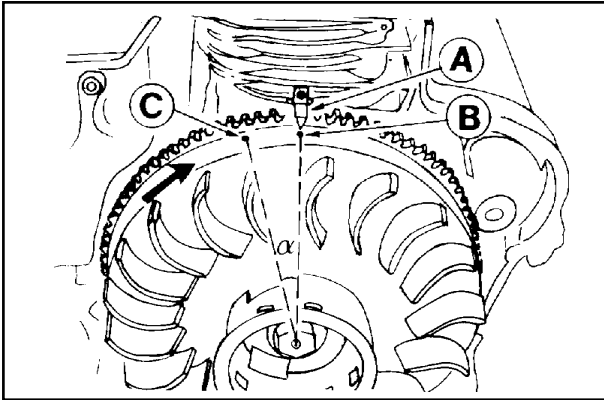
**115**
**Static injection lead test on flywheel**

Fill the tank and make sure that the fuel is not more than 10-15 cm above the tester. Set the flow governor lever of the injection pump in the stop position and lock it there.

Turn the flywheel in the engine rotation direction. proceed slowly during the compression phase. The fuel that flows from tube 2 will tend to diminish. Stop as soon as it ceases to drip (one drop of fuel every 30-40 seconds is tolerated): this is the static injection lead. Make sure that **B** coincides with **A**.

See fig. 117-118 if **B** does not coincide with **A**.



Use a temporary tank if the engine is not fitted with one. Here again, it is essential to make sure that the fuel level is no more than 10-15 cm above the injection pump.

**References on the flywheel**

**A** = Reference of fixed TDC on crankcase

**B** = Injection lead reference on the flywheel

**C** = TDC reference on flywheel

$\alpha$  = Reference in degrees between **B** and **C**.

When **B** coincides with **A**, the piston is in the static injection lead position. When **C** coincides with **A**, the piston is at top dead center.

Motor type	B/C m m				$\alpha$
	with external Ø flywheel 220	with external Ø flywheel 230	with external Ø flywheel 240	with external Ø flywheel 260	
KD 225 standard	40÷44	42÷46			21÷23
KD 225 recorded up to 1500 [rpm]	29÷32,5	30÷34			15÷17
KD 225 recorded from 1500 to 2200 [rpm]	34,5÷38	36÷40			18÷20
KD 315/350 standard and minivecture		46÷50	48÷52		23÷25
KD 315/350 Soundproof generating sets		40÷44	42÷46		20÷22
KD 315/350 recorded to 1500 [rpm]		36÷40	38÷42		18÷20
KD 400 recorded to 3600 [rpm]				29,48	13
KD 400 recorded to 3000 [rpm]				24,95	11
KD 400 EPA recorded to 3600 [rpm]				28,35	12,5
KD 400 EPA recorded to 3000 [rpm]				24,95	11
KD 440 recorded to 3600 [rpm]				31,75	14
KD 440 recorded to 3000 [rpm]				27,21	12

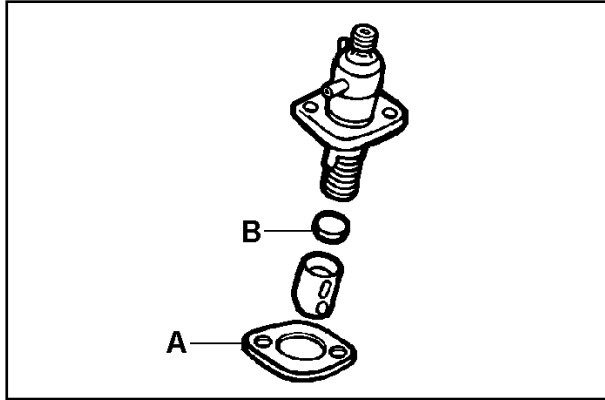

116

**Injection advance adjustment**

Injection advance beyond the thickness of gasket **A** is determined by the thickness of the pad inside the injection tappet.  
 To alter the value of injection advance the pad must be replaced with another of a suitable thickness (see fig. 117-118).  
 To extract pad **B**, use a rod with a suction cap or magnet at one end.  
 The replacement pads supplied have 10 different thicknesses (between 4.0 and 4.9mm).  
 To alter the value of injection advance the pad must be replaced with another of a suitable thickness (see fig. 117-118).

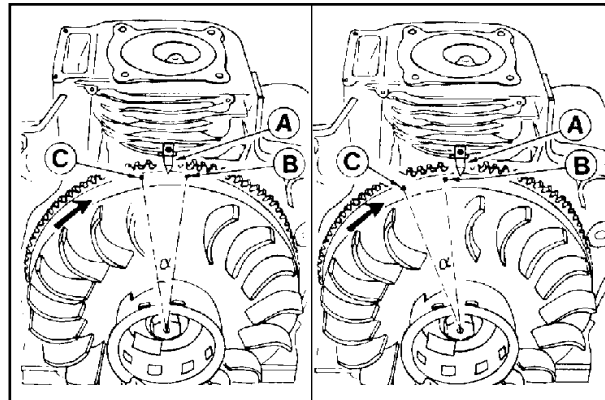

117

118

If reference point **B** does not coincide with **A** follow the examples in fig. 117-118.

- 1) Example of delayed injection advance (fig. 117): to make **B** match up with **A**, replace the pad with a thicker one (fig. 116).
- 2) Example of early injection advance (fig. 118): to make **B** match up with **A**, replace the pad with a thinner one (fig. 116).

**Note:** When the thickness of the pad varies by 0.1mm under the pump, **B** is delayed or brought forward by 1° on the flywheel.

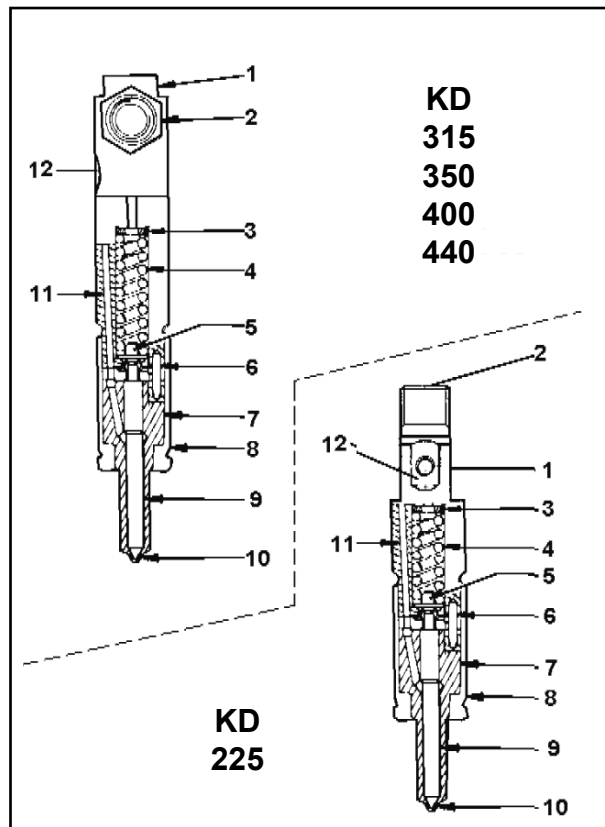

119

**Injector**

Components:

- 1 Body
- 2 Union
- 3 Adjusting shim
- 4 Spring
- 5 Pressure rod
- 6 Pin
- 7 Nozzle
- 8 Nozzle cup
- 9 Needle valve
- 10 Tip
- 11 Duct
- 12 Return hole

After re-assembly, tighten ring nut **8** to a 50 Nm torque value.

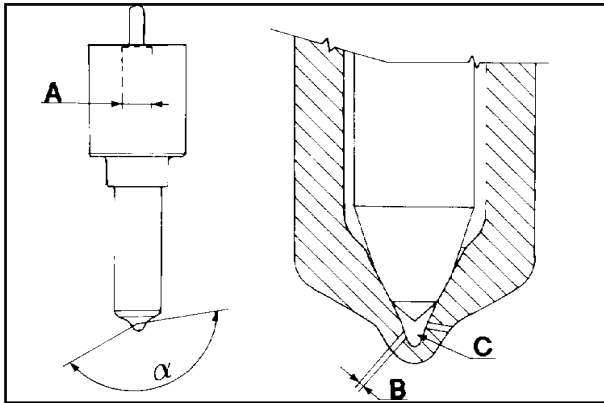
**120**
**Nozzles**

The set-up between the needle and the guide must leave the needle free to fall and merely as a result of its own weight, when lifted 7mm from its seat and rotated in different directions, with the nozzle kept at a 45° angle.

Rotation of the needle must be completely smooth and uninhibited by obstacles and malformations.

Moreover, on being squeezed against its seat, it must fall freely, when the nozzle is inverted.

The test must be carried out after rinsing both the needle and nozzle with trichloroethane and wetting with filtered SHELL CALIBRATION FLUID "C" oil.

A	4,5	4,5	4,5	4,5	4,5	4,5	4,5	4,5	4,5
B n° and Ø of holes	4 x 0,17	4 x 0,20	5 x 0,141	4 x 0,22	5 x 0,141	5 x 0,159	5 x 0,150	5 x 0,166	5 x 0,165
hole lenght	0,5	0,6	0,8	0,6	0,8	0,5	0,8	0,5	0,8
a	160°	160°	155°	160°	145°	160°	160°	160°	155°
pin height	0,10 ÷ 0,15	0,10 ÷ 0,15	0,175 ÷ 0,225	0,125 ÷ 0,175	0,175 ÷ 0,225	0,375 ÷ 0,425	0,375 ÷ 0,425	0,375 ÷ 0,425	0,375 ÷ 0,425
C sump volume	0,36 mm <sup>3</sup>	0,36 mm <sup>3</sup>	0 mm <sup>3</sup>	0,36 mm <sup>3</sup>	0 mm <sup>3</sup>	0,19 mm <sup>3</sup>	0 mm <sup>3</sup>	0,19 mm <sup>3</sup>	0 mm <sup>3</sup>
pressure (bar)*	214 ± 4	214 ± 4	240 ± 6	214 ± 4	240 ± 6	200 ± 4	259 ± 4	200 ± 4	240 ± 6

\* These values apply to new injector and allow for loosening of up to 10% after breaking-in period

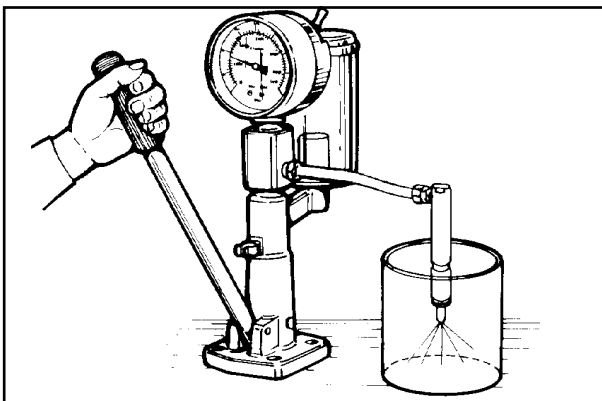
**121**
**Injector calibration**

Connect the injector to a hand pump and adjust if necessary, modifying the thickness above the spring.

When the spring is replaced, calibration must be carried out at a pressure higher than 10 bars to counterbalance adjustments while running.

**Spraying and opening pressure**

With the pressure gauge closed, press hard on the hand pump at least 10 times.

Open the pressure gauge and press down on the pump once every second, while keeping a check on the spraying process and pressure.

The opening pressure must lie between the two values given in the table. Jets must be uniform and well distributed.

**Leakage time (waste)**

Pressure must drop from 150 to 100 bars in a span of not less than 8 seconds and not more than 30.

**Seat seal**

Nozzle tip wet.

Pressure must be kept 20 bars below the opening pressure for 10 seconds.

After this time, dampness on the nozzle tip is acceptable, and may be identified by touching with a dry finger. Only a drop of dampness is acceptable and not a large thick patch which would indicate a leak.



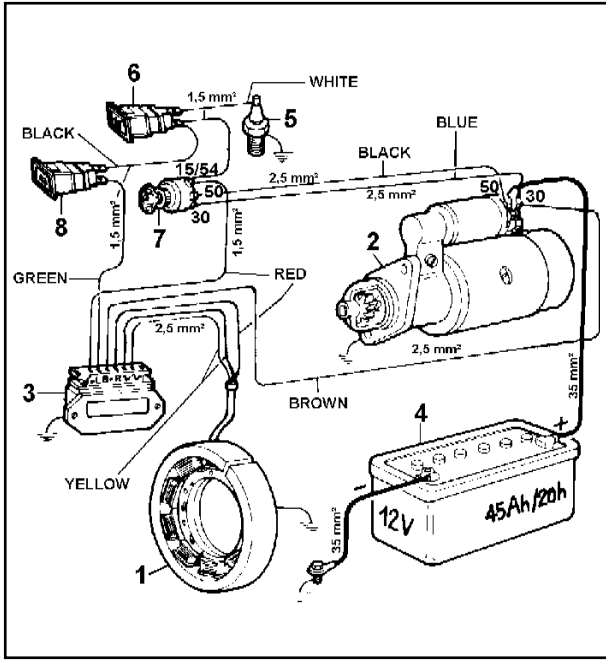

122

12V, 12A electric ignition diagram

Components:

- 1 Alternator
- 2 Starter motor
- 3 Voltage regulator
- 4 Battery
- 5 Pressure switch
- 6 Oil pressure light
- 7 Key switch
- 8 Battery charging light

**Note:** The battery, which is not supplied by REHLKO, should have 12V nominal voltage rating and a capacity of not less than 44 Ah / 210 Amp. of fast discharge intensity.

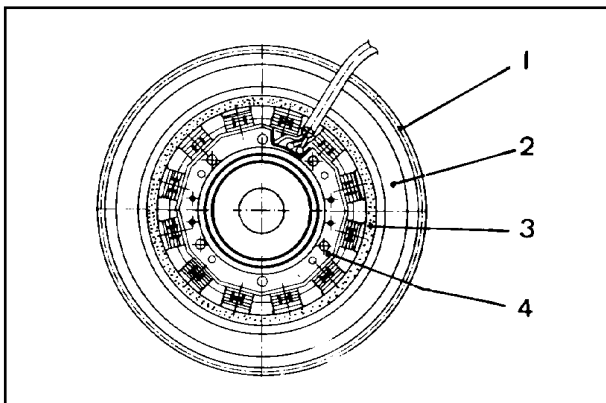

123

Alternator

Components:

- 1 Ring gear
- 2 Flywheel
- 3 Rotor
- 4 Stator

Fixing screws must be tightened to 1.2 Nm.

**Note:** The rotor is made up by a plastoferrite ring which is fixed to flywheel while the stator is mounted on the crankcase.

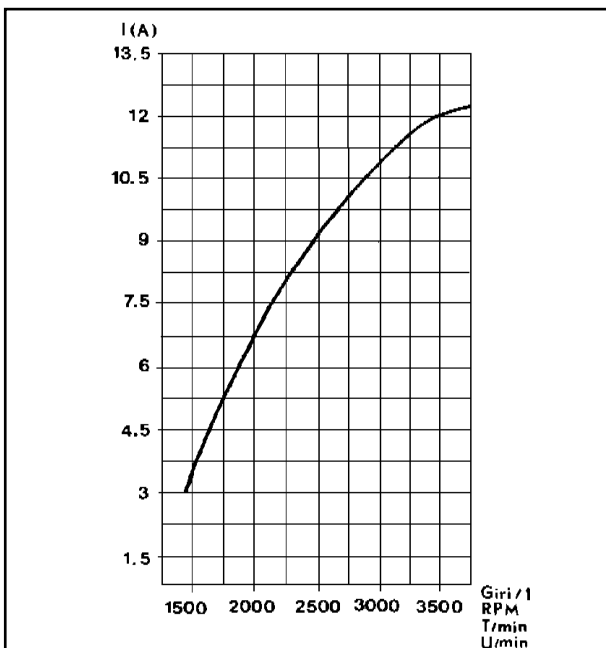

124

Alternator battery charger graph (12V, 12A)

This test has been carried out after thermal stabilization at 20°C for 2 minutes at 3000 r.p.m. with constant battery voltage of 12.5V. The value of the power supplied with reference to the curve may change in a range between +10% and -5%.

24V, 9A alternator battery recharging curve

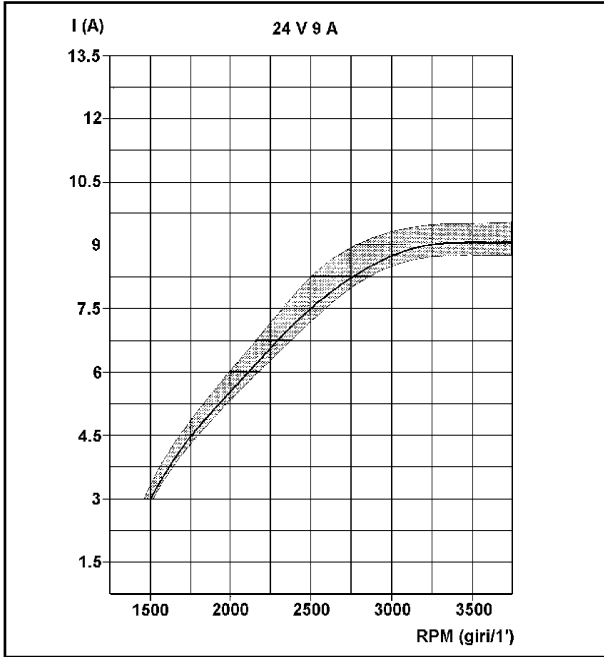

125

12V, 30A alternator battery recharging curve

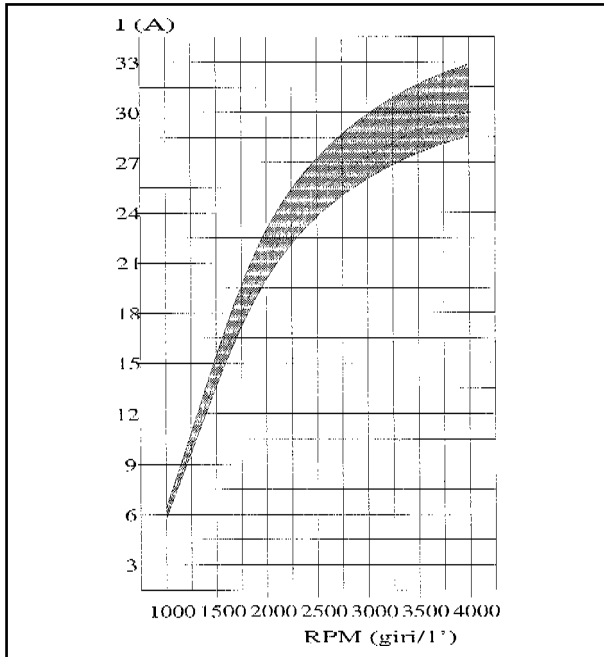

The test was conducted after heat stabilizing at 20°C. The value of the current delivered in relation to the curve may be subjected to a variation of between +10 % and -5%.

126

Voltage regulator

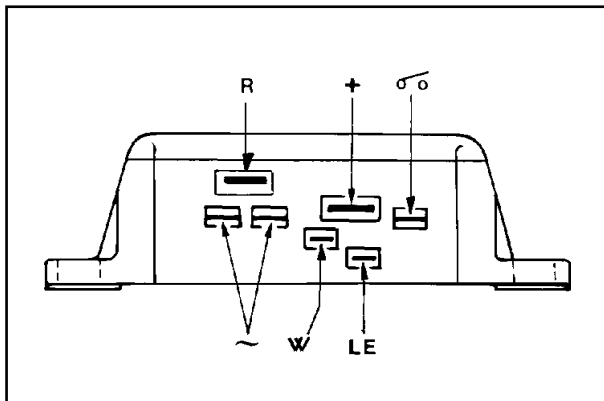

12V, 12A: for standard alternators with 3 output wires  
 12V, 30A: for 12V, 20A alternators with 2 output wires  
 24V, 9A: for 24V, 9A alternators with two output wires

Tab dimensions mm		
	Width	Thickness
~	6.35	0.80
R	9.50	1.12
+	9.50	1.12
LE	4.75	0.50
σ	6.35	0.80
W	4.75	0.50

The tabs are in different sizes to prevent incorrect connections.

127

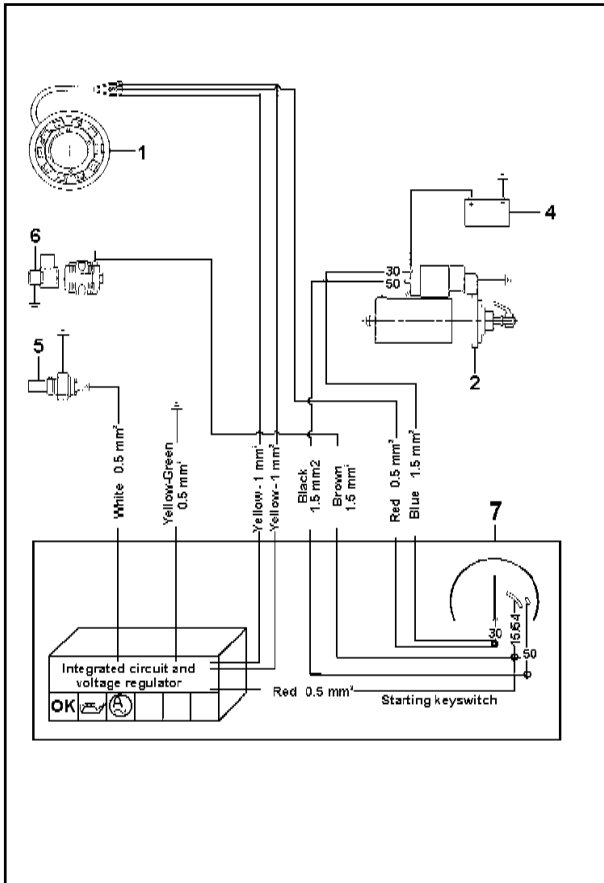

**12V electric starter diagram with voltage regulator built into the ignition panel**

Components:

- 1 Alternator
- 2 Starter motor
- 4 Battery
- 5 Pressure switch
- 6 Solenoid valve
- 7 Ignition switch

**Note:** The battery, which is not supplied by REHLKO, should have 12V nominal voltage rating and a capacity of not less than 44 Ah / 210 Amp. of fast discharge intensity.

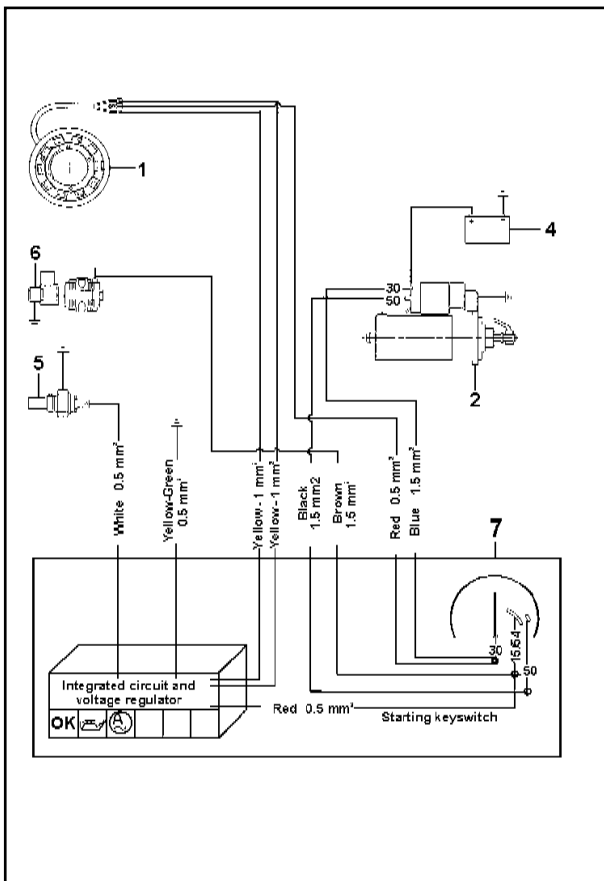
128



**12V electric ignition layout with motor protection (optional)**

Components:

- 1 Alternator
- 2 Starter motor
- 4 Battery
- 5 Pressure switch
- 6 Solenoid valve
- 7 Ignition switch
- 8 Panel

**Note:** The battery, which is not supplied by REHLKO, should have 12V nominal voltage rating and a capacity of not less than 44 Ah / 210 Amp. of fast discharge intensity.

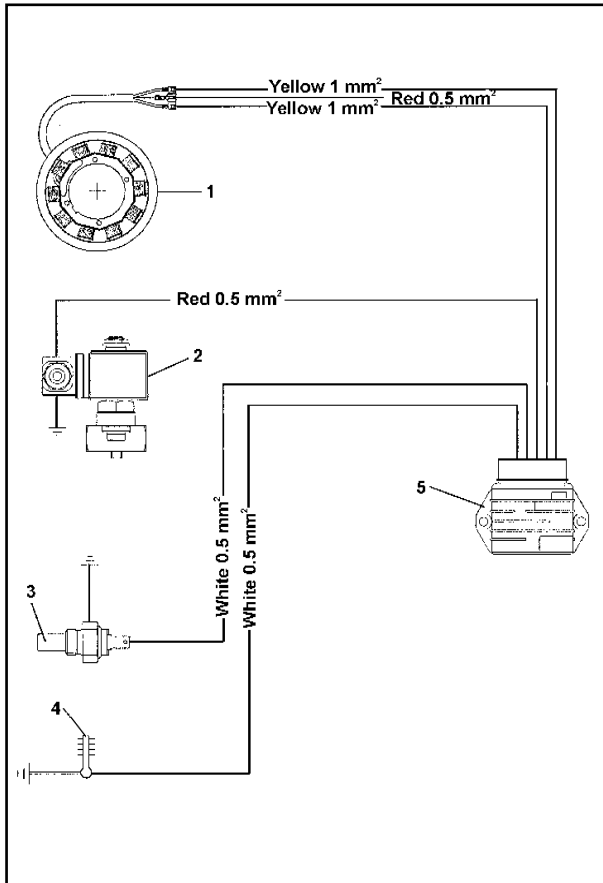
129



**Diagram of electric starter motor protection with sole self-winding starter - without battery - (optional)**

Components:

- 1 Alternator
- 2 Solenoid valve
- 3 Pressure switch
- 4 Thermostat
- 5 A.c. motor stop device

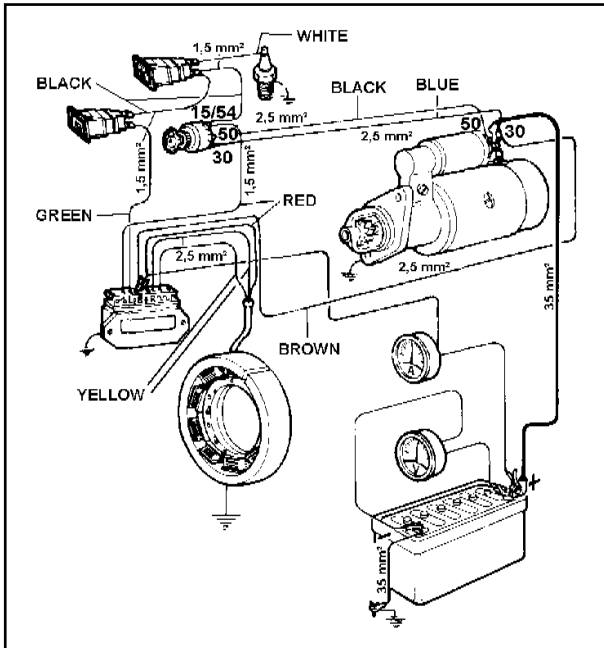

131

**Testing voltage regulator for proper operation**

Check that connections correspond to the schematic. Disconnect the terminal from the battery positive pole. Connect a d.c. voltmeter between the battery poles. Fit an ammeter between the positive pole and the **B+** on voltage regulator. Start and stop the engine a several times until battery voltage drops below 13V. When battery voltage reaches 14.5V the ammeter current should suddenly drop down to almost zero. Replace regulator if recharge current is zero with voltage below 12,5V.

**!** When the engine is running do not disconnect battery cables or switch key to "off" position. Keep regulator away from heat sources above 75°C. Do no electric welding on engine or application.

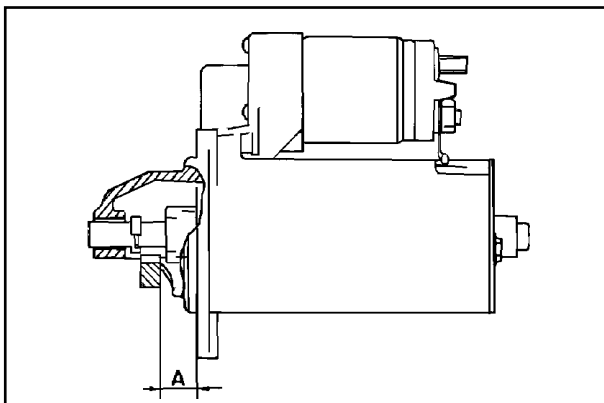

132

**Starting motor**

**Bosch type DW (L) 12V, 1.1 KW for KD 315-350-400-440**  
**Bosch type DW (L) 12V, 0.9 KW for KD 225**

Anti-clockwise rotation direction (viewed from pinion side)  
**A** = 17.5-19.5 mm (distance from flywheel rim surface to starter motor flange surface)

**Note:** Contact Bosch service centers for repair operations.

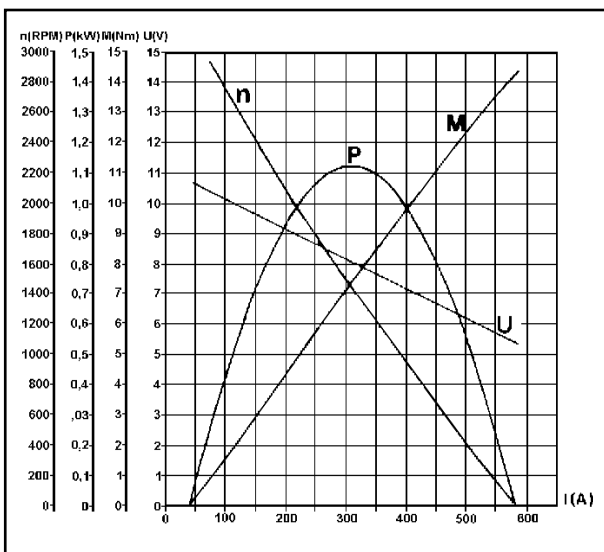

133

**Characteristic curves for starting motor type DW (L) 12V, 1.1 KW**

The curves were obtained at a temperature of -20°C with 66 Ah battery.

**U** = Motor terminal voltage in Volts  
**n** = Motor speed in r.p.m.  
**M** = Torque in Nm  
**J(A)** = Absorbed current in Ampere.

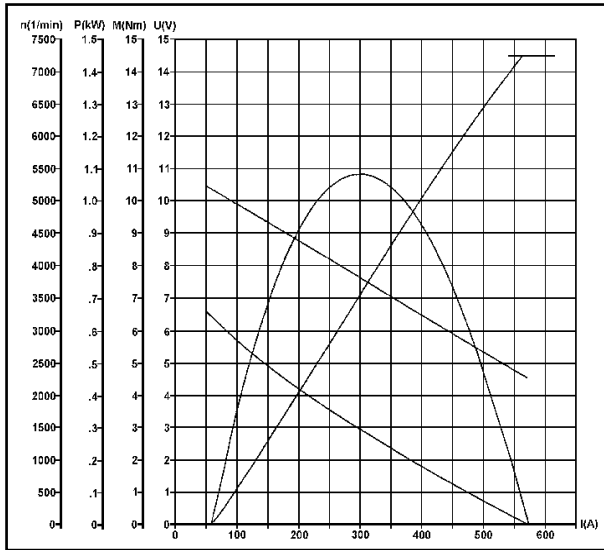

**Characteristic curves of Bosch starter motor type DW (L) 12V, 0.9 kW**

The curves were measured at a temperature of -20°C with a 55 Ah battery.

- U** = Voltage on motor terminals in Volts.
- n** = Motor speed in rpm
- M** = Torque in Nm
- I (A)** = Power draw in Amperes.

134

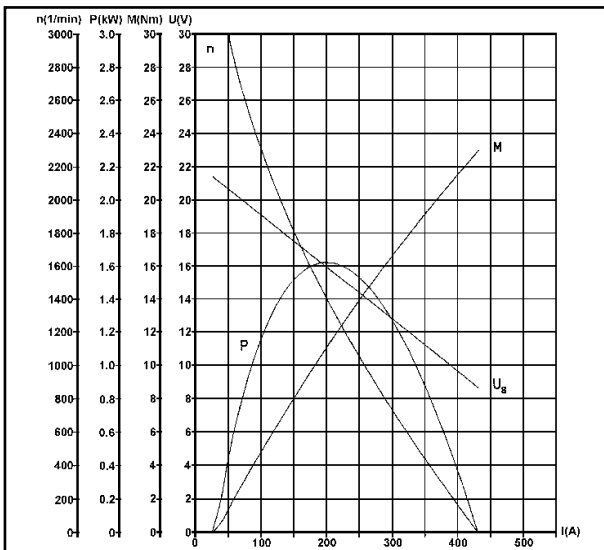

**Characteristic curves of Bosch starter motor type DW (L) 24V, 1.6 kW**

The curves were measured at a temperature of -20°C with a 36 Ah battery.

- U** = Voltage on motor terminals in Volts.
- n** = Motor speed in rpm
- M** = Torque in Nm
- I (A)** = Power draw in Amperes..

135

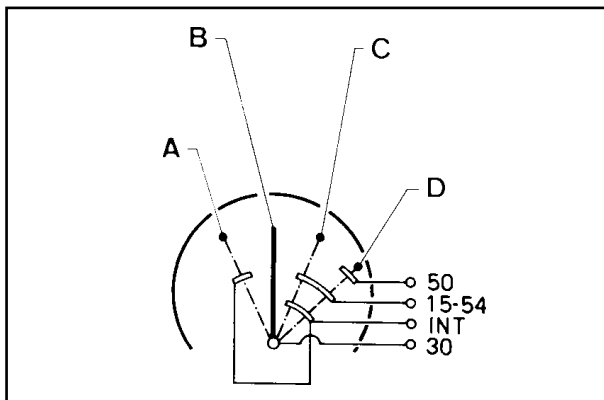

**Ignition switch positions**

- A** = Accessory
- B** = Off
- C** = On
- D** = Start

136

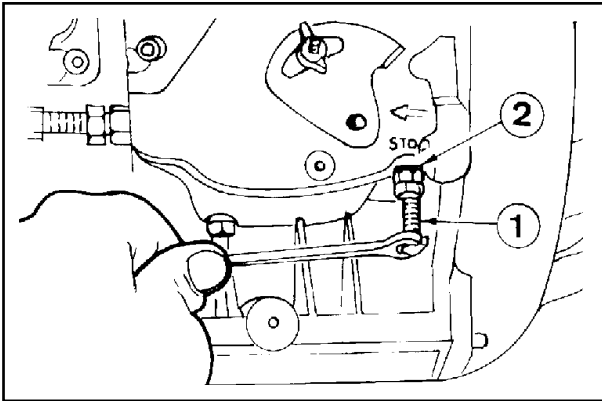

137

**ADJUSTMENTS - KD 315-350**

**Idling speed setting in no-load conditions (standard)**

After filling with oil and fuel, start the engine and let it warm up for 10 minutes.  
 Adjust idling speed to 1000-1250 rpm by turning set screw 1; then tighten lock nut.  
 Washer 2 assures sealing and prevents possible oil leaks.

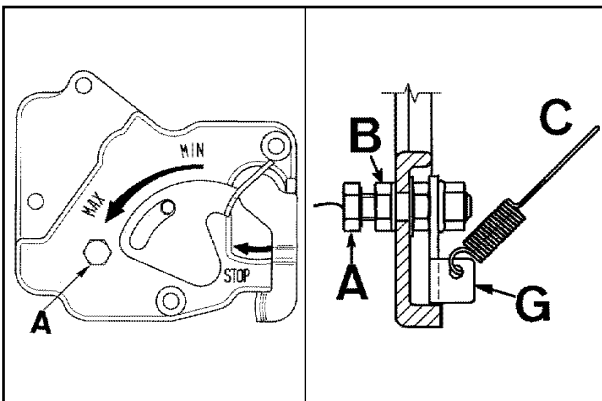

138

139

**Idle speed adjustment, for small car versions**

The idle speed adjusting spring (C) for small cars must be hooked in the speed governor lever hole D ( fig.140).  
 Completely unscrew the std idle speed adjusting screw 1 (fig.137).  
 Loosen nut B by one half of a turn.  
 Turn the screw A anticlockwise until lever G touches cover.  
 Start the engine: turning clockwise screw A, set idle speed at 1050 rpm ; tighten the lock nut B tighten the screw 1 (fig. 137) until touching lever H (fig. 141); when the screw touches the lever, the speed increases; at this point unloose screw 1/4 of a turn and lock the lock nut of screw 1.

The controls cover screws must be tightened to 10Nm.

**Note:** By this way idle speed on hot engine could diminish of 80 rpm max.

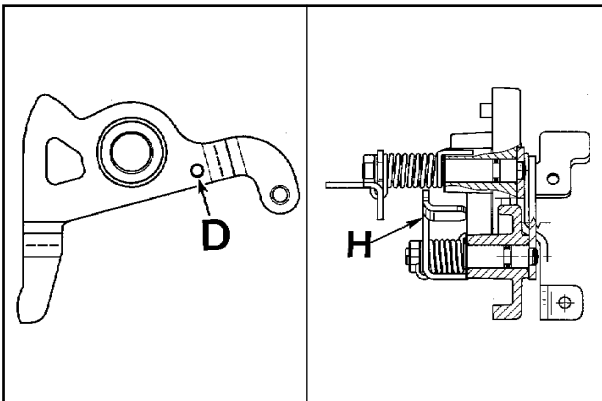

140

141

**Full speed setting in no-load conditions (standard)**

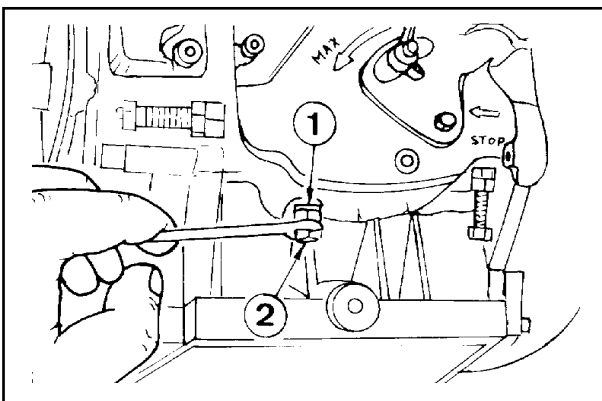

142

After setting idle speed turn screw 2 and set full speed in no-load conditions at 3800 rpm; then tighten lock nut.  
 Washer 1 assures sealing and prevents possible oil leaks.

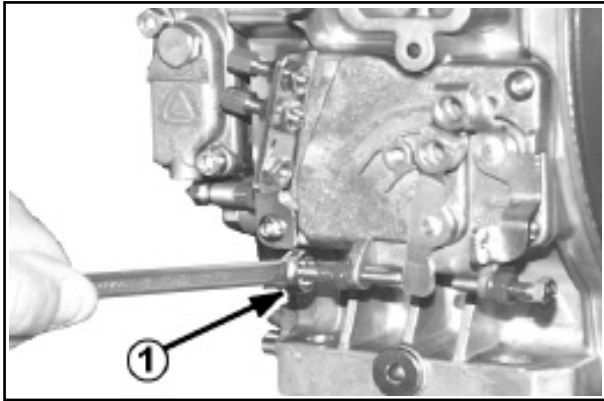

143

**ADJUSTMENTS - KD 225-400-440**

**No-load idling adjustment (standard)**

After having filled the engine with oil and fuel, start it and allow it to warm up for 10 minutes.  
Using adjuster screw 1, regulate the idling rate at 1000-1250 rpm.  
Tighten the check nut.

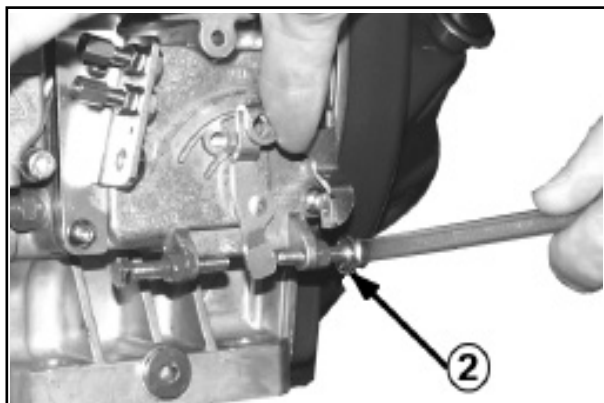

144

**No-load top rate adjustment (standard)**

After having adjusted the idling rate, use screw 2 and regulate the top rate at 3800 rpm (for engines set at 3600 rpm on load).  
Tighten the check nut.

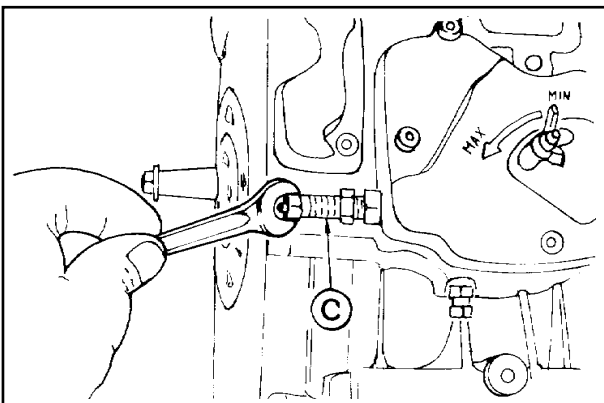

145

**Injection pump flow rate adjustment for KD 225-315-350-400-440**

This regulation must be carried out by means of a water brake, otherwise the adjustment will be approximate. proceed in the following way.  
Loosen flow rate limiter C by 5 turns.  
Accelerate the engine to no-load top rate, i.e. to 3800 rpm.  
Re-tighten limiter C until the engine tends to decelerate.  
Loosen limiter C by one and a half turns.  
Tighten the check nut.

**Note:** Tighten C if the engine produces an excessive amount of exhaust in the maximum load condition; loosen C if no smoke is exhausted and if the engine is unable to develop its maximum power.

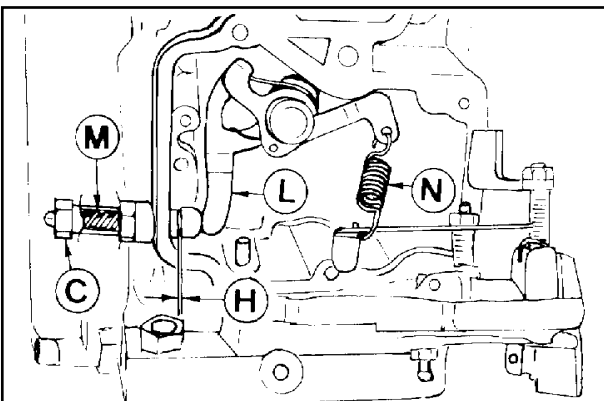

146

**Injection pump delivery limiting and torque adapter (standard)**

Delivery limiting device C has the function of limiting the injection pump max. delivery.  
The same device also acts as torque adapter. The speed governor spring acts on lever L with standing the resistance opposed by spring M inside the cylinder.  
The stroke H allowed by the torque device to lever L is 0.20 / 0.25 mm.  
As a result of this pump delivery increases and torque reaches its peak value.

**Note:** In generator sets and power welders, the torque setting device acts as a delivery limiter only.

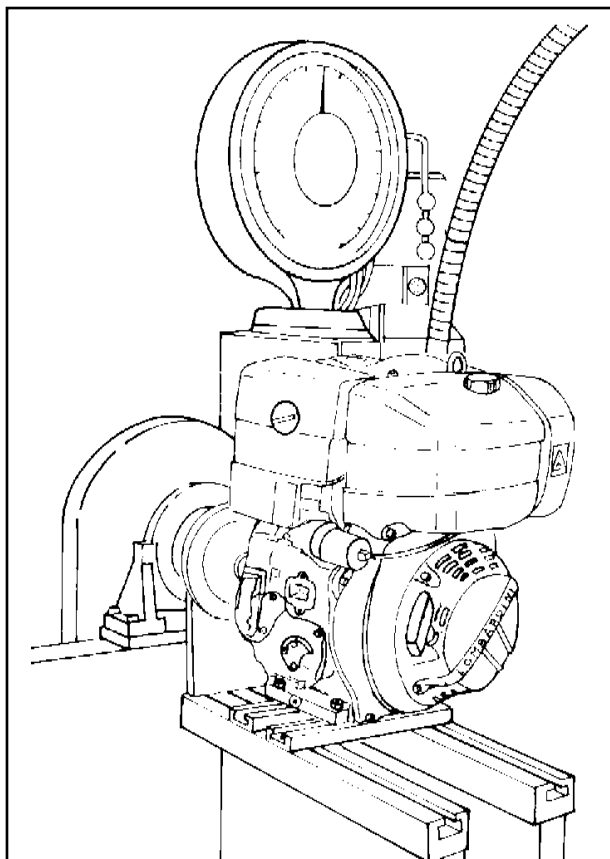

148

**Injection pump delivery setting**

- 1) Bring engine to idling speed
- 2) Unscrew delivery limiting device **C** ( see fig. 145)
- 3) Bring the engine to the power and rpm required by the manufacturer of the device.
- 4) Check that fuel consumption falls within the table specifications (see below).  
If consumption is not as indicated change balance conditions at the torque dynamometer by varying the load and adjusting the governor. Under stable engine conditions check consumption again.
- 5) Tighten limiting device **C** until the engine rpm decreases.  
Lock the limiting device by means of lock nut.
- 6) Release brake completely and check at what speed the engine becomes stable  
Speed governor should comply with the requirements of the class indicated by the manufacturer of the device.
- 7) Stop the engine.
- 8) Check valve clearance when engine has cooled down.

**Required settings (the most common ones)**

Engine	R.P.M.	Power kW	Specific fuel consumption	
			Time (sec) pour 100 cc	g/kW h
<b>225</b>	3600	3,50	298	287
	3000	3,0	357	280
<b>315</b>	3600	5,0	242	275
	3000	4,5	283	265
<b>350</b>	3600	5,5	198	275
	3000	4,9	235	260
<b>400</b>	3600	7,3	151	275
	3000	6,3	184	260
<b>440</b>	3600	8,0	137	275
	3000	7,2	160	260

When the engines are not used for more than 3 months, they must be protected by the measures described below:

### STORAGE

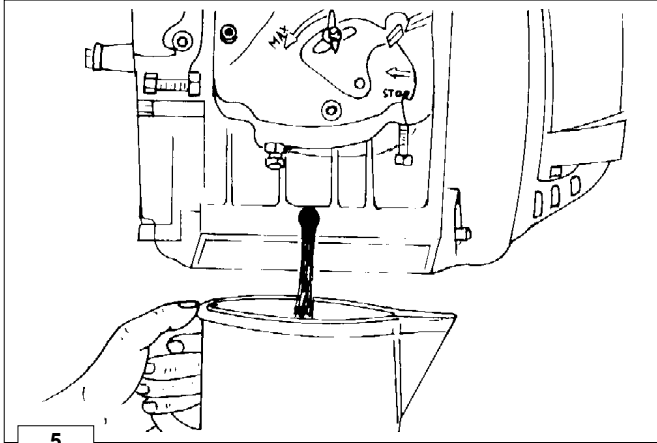

#### Internal engine protection:

- Start the engine and allow it to heat up.
- Remove the drain plug and let the oil flow out completely.
- Replace the oil filter with a new one.
- Clean the oil drain plug and after inserting a new gasket, tighten it.
- Fill up with oil to the upper level of the dipstick, using **REHLKO X-treme** (or an equivalent product meeting the recommended specifications).
- Start the engine for about 10 minutes, check for oil leaks, and then stop the engine.

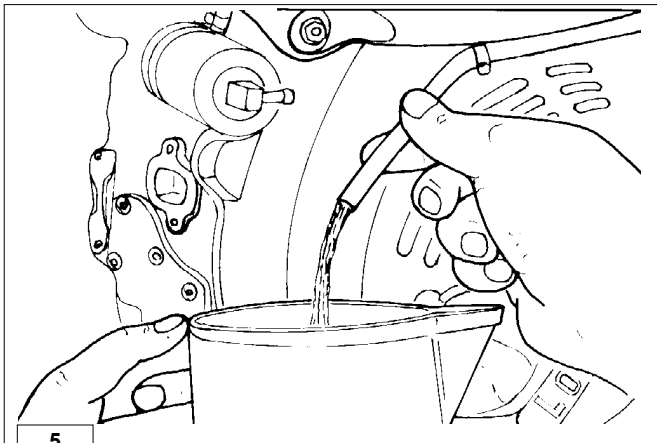

#### Injection systems protection:

- Empty the fuel tank.
- Replace the fuel filter with a new one.
- Fill up with fuel containing 10% **AGIP RUSTIA NT**.
- After bleeding air, start the engine, make sure there are no fuel leaks and then stop the engine.

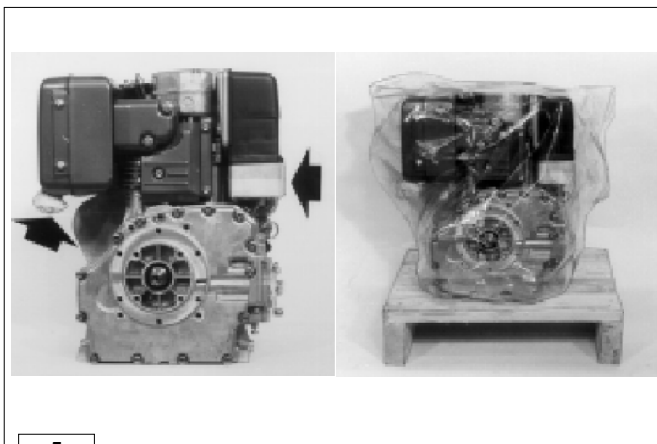

#### External engine protection:

- Carefully clean the cylinder cooling system fins and the flywheel fins.
- Protect the external non-painted surfaces with **AGIP RUSTIA 68/F**.
- Seal the intake and exhaust systems with adhesive tape.
- Cover the engine with a nylon or plastic sheet.
- Store in a dry place, preferably not directly on the ground and away from high voltage electricity lines.

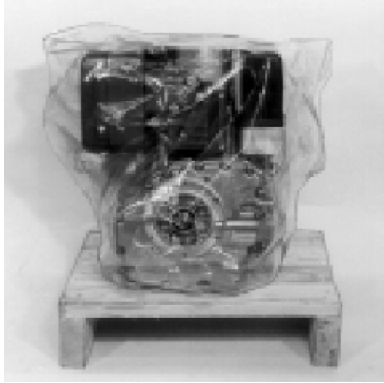
**PROCEDURES TO BE CARRIED OUT BEFORE START THE ENGINE**

**174**

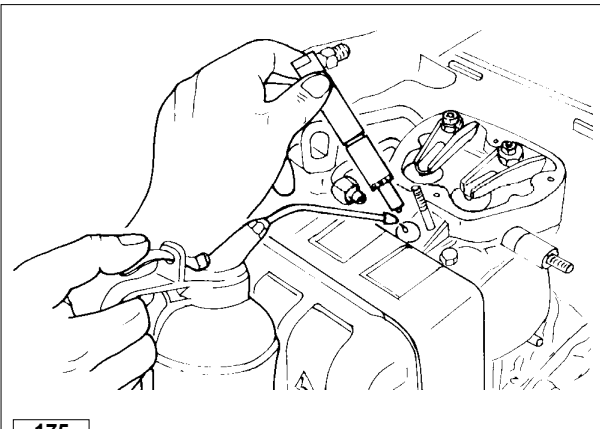
- Remove all protections and coverings.
- Remove the protective oil from the outside of the engine using suitable products (solvent or degreaser).
- Remove the injector and, using a flask, pour engine oil on the piston crown (no more than 2 cc).
- Remove rocker arm cover and spray engine oil on the valves, then turn the crankshaft manually a few revolutions.
- Start the engine and allow it to heat up for about 10 minutes.
- Remove the drain plug and let the protective oil flow out completely.

**175**

- Replace the drain plug.
- Fill up with engine oil as far as the upper level of the dipstick using the oil recommended by the manufacturer for normal engine operation.





**MAIN TORQUE SPECIFICATIONS**

POSITION	Reference ( fig. N° and page)	Diam. and pitch ( mm )	Torque ( Nm )	Torque ( Nm )	Torque ( Nm )
			225	315-350	400-440
Re-coil starting	fig. 18 - p. 25	6x1	10	10	10
Connecting rod, aluminium	fig. 51 - p. 36	8x1	-	30	30
		7x1	23	-	-
Connecting rod, steel	fig. 13 - p. 23	8x1	-	-	35
Rocker arm adjusting screw lock nut	fig. 13 - p. 23	6x0,5	7	7	10
Rocker arm adjusting screw pin	fig. 19 - p. 25	8x1,25	20	20	6
Shroud	fig. 12 - p. 23	6x1	10	10	10
Rocker arm cover		6x1	10	10	10
Control arm cover	-	6x1	10	10	10
Enhanced engine oil sump	-	10x1,5	-	-	40
Exhaust manifold	-	8x1,25	-	-	25
Air cleaner support	fig. 3 - p. 20	8x1,25	25	25	25
Oil filter head	fig. 90 - p. 49	6x1	10	10	10
Injection tappet guide screw	fig. 103-104 - p. 53	6x1	9	9	9
Injector fixing onto the head	-	6x1	12	9	9
Muffler on manifold	fig. 9-10 - p. 22	8x1,25	25	25	25
Fuel pump	fig. 100 - p. 52	8x1,25	15	15	15
Injection pump union	-	14x1,5	40	40	40
Injection pump fastening screws	fig. 102 - p. 53	6x1	15	10	10
Oil pump support	fig. 84 - p. 48	6x1	10	10	10
Gear cover, timing side	fig. 81 - p. 45	8x1,25	23	23	23
Calibrated fitting for hydraulic tappet lubrication	-	10x1,5	-	-	15
Injection pump delivery union	fig. 105 - p. 54	14x1,5	-	-	40
Fuel tank bottom lower fixing	fig. 14 - p. 24	8x1,25	15	15	15
Enhanced sump half-shells	-	8x1,25	-	-	15
Fuel tank top fixing	-	14x1,5	20	20	20
Oil drain plug	fig. 21 - p. 26	-	-	-	-
Cylinder head (*)	fig. 21 - p. 26	6x1	10	10	10
Flywheel pulley fixing screws	-	8x1,25	-	-	25
Flywheel	fig. 20 - p. 25	14x1,5 sinistra	150	150	150



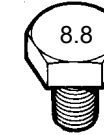
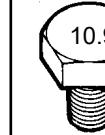
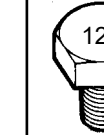

**USE OF SEALANT**

POSITION	TYPE OF SEALANT
Locking of adjustment lever box	Loctite 648 BV
Air valve case	Loctite "Form-a-gasket N.6"
M6 fixing screw for fuel filter	Loctite 222
M8 fixing screw for muffler bracket	Loctite 222
M8 fixing screws for fuel supply pump	Loctite 222
M16 fixing screw for oil intake filter and cover	Loctite 222
M6 fixing screws for air shroud	Loctite 222
M6 stud bolt for dry air filter cover	Loctite 270
M6 fixing screws for side oil refilling union	Loctite 270
M6 screw for injection tappet guide	Loctite 270
M8 STEI screw for closing oil intake hole cover	Loctite 270
M8 STEI screw for closing crankcase lubrication hole	Loctite 270
M8 fixing screws for air filter support and intake manifold	Loctite 270
Rocker arm fulcrum screws	Loctite 270
Stator screws	Loctite 270
M8 stud bolts for tank	Loctite 270
Plastoferrite on flywheel	Loctite 480
Base coupling surface - cover	Loctite 5205
Coupling surface for enhanced engine oil sump	Loctite 5205
Coupling surface for enhanced oil sump half-shells	Loctite 5205
Hydraulic tappet contact - cam	MOLYSLIP AS COMPOUND 40

**Table of tightening torques for standard screws (coarse thread)**

Resistance class (R)								
Quality/ Dimensions								
Diameter	R>400N/mm <sup>2</sup>		R>500N/mm <sup>2</sup>		R>600N/mm <sup>2</sup>	R>800N/mm <sup>2</sup>	R>1000N/mm <sup>2</sup>	R>1200N/mm <sup>2</sup>
	Nm	Nm	Nm	Nm	Nm	Nm	Nm	Nm
M3	0,5	0,7	0,6	0,9	1	1,4	1,9	2,3
M4	1,1	1,5	1,4	1,8	2,2	2,9	4,1	4,9
M5	2,3	3	2,8	3,8	4,5	6	8,5	10
M6	3,8	5	4,7	6,3	7,5	10	14	17
M8	9,4	13	12	16	19	25	35	41
M10	18	25	23	31	37	49	69	83
M12	32	43	40	54	65	86	120	145
M14	51	68	63	84	101	135	190	230
M16	79	105	98	131	158	210	295	355
M18	109	145	135	181	218	290	405	485
M20	154	205	193	256	308	410	580	690
M22	206	275	260	344	413	550	780	930
M24	266	355	333	444	533	710	1000	1200
M27	394	525	500	656	788	1050	1500	1800
M30	544	725	680	906	1088	1450	2000	2400

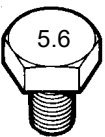
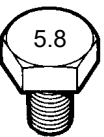
**Table of tightening torques for standard screws (fine thread)**

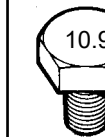
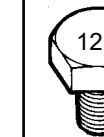
Resistance class (R)								
Quality/ Dimensions								
Diameter	R>400N/mm <sup>2</sup>		R>500N/mm <sup>2</sup>		R>600N/mm <sup>2</sup>	R>800N/mm <sup>2</sup>	R>1000N/mm <sup>2</sup>	R>1200N/mm <sup>2</sup>
	Nm	Nm	Nm	Nm	Nm	Nm	Nm	Nm
M 8x1	10	14	13	17	20	27	38	45
M 10x1	21	28	26	35	42	56	79	95
M 10x1,25	20	26	24	33	39	52	73	88
M 12x1,25	36	48	45	59	71	95	135	160
M 12x1,5	38	45	42	56	68	90	125	150
M 14x1,5	56	75	70	94	113	150	210	250
M 16x1,5	84	113	105	141	169	225	315	380
M 18x1,5	122	163	153	203	244	325	460	550
M 18x2	117	157	147	196	235	313	440	530
M 20x1,5	173	230	213	288	345	460	640	770
M 20x2	164	218	204	273	327	436	615	740
M 22x1,5	229	305	287	381	458	610	860	1050
M 24x2	293	390	367	488	585	780	1100	1300
M 27x2	431	575	533	719	863	1150	1600	1950
M 30x2	600	800	750	1000	1200	1600	2250	2700



Contacts: <https://www.engines.rehiko.com/contact>  
Parts Catalogue: [Global Parts Lookup](#)