

KD 441 | Horizontal Crankshaft

WORKSHOP MANUAL

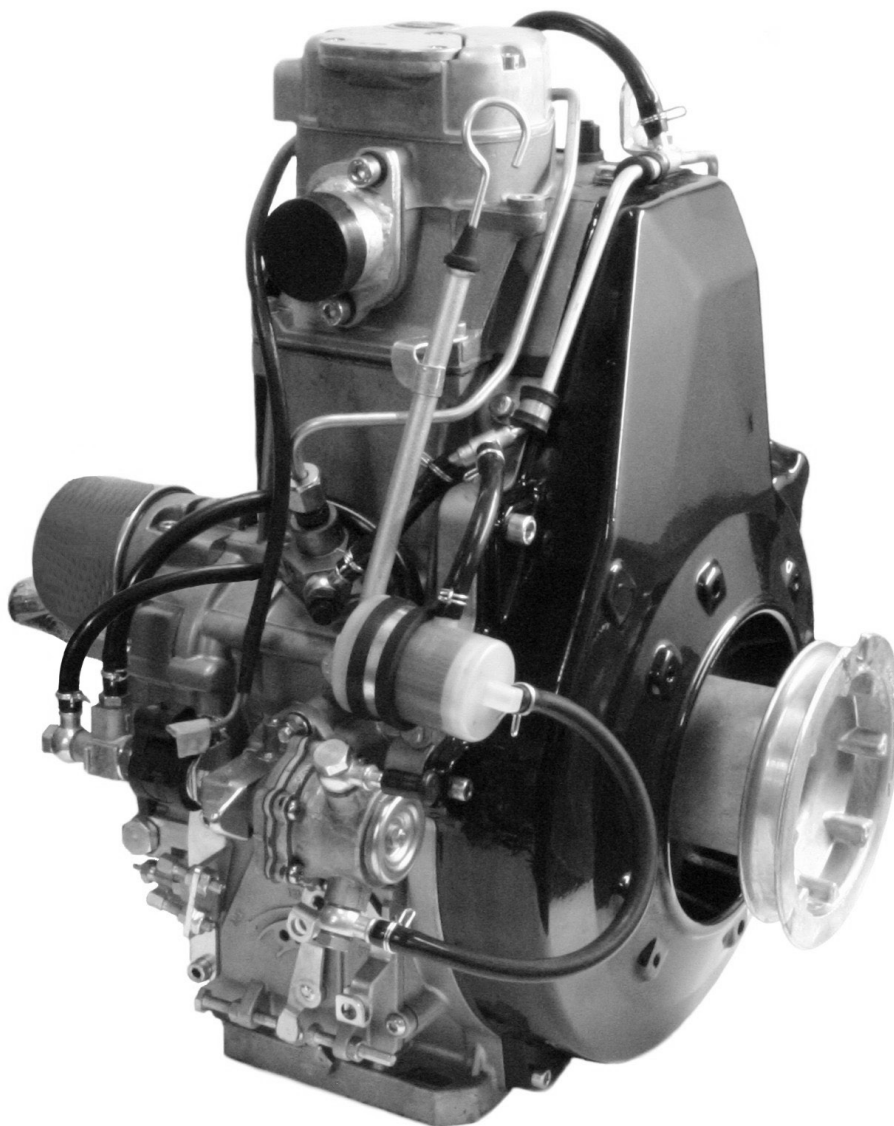

 **rehlko**

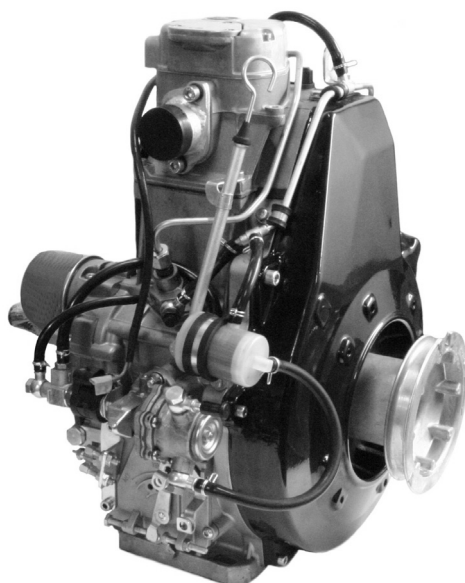

KD 441 Engine Series

PREFACE

- Every attempt has been made to present within this service manual, accurate and up to date technical information.
However, development on the **REHLKO** series is continuous.
Therefore, the information within this manual is subject to change without notice and without obligation.

- The information contained within this service manual is the sole property of **REHLKO**.
As such, no reproduction or replication in whole or part is allowed without the express written permission of **REHLKO**.

Information presented within this manual assumes the following:

- 1 - The person or people performing service work on **REHLKO** series engines is properly trained and equipped to safely and professionally perform the subject operation;
- 2 - The person or people performing service work on **REHLKO** series engines possesses adequate hand and **REHLKO** special tools to safely and professionally perform the subject service operation;
- 3 - The person or people performing service work on **REHLKO** series engines has read the pertinent information regarding the subject service operations and fully understands the operation at hand.

- This manual was written by the manufacturer to provide technical and operating information to authorised **REHLKO** after-sales service centers to carry out assembly, disassembly, overhauling, replacement and tuning operations.
- As well as employing good operating techniques and observing the right timing for operations, operators must read the information very carefully and comply with it scrupulously.
- Time spent reading this information will help to prevent health and safety risks and financial damage.
Written information is accompanied by illustrations in order to facilitate your understanding of every step of the operating phases.

REGISTRATION OF MODIFICATIONS TO THE DOCUMENT

Any modifications to this document must be registered by the drafting body, by completing the following table.

Drafting body Ente compilatore Organisme rédacteur Austeller Entidad redactora Entidade compiladora	Document code Codice documento Code document Buchcode Cod. libro Cód. di libro	Revision Revisione Révision Vertatung Revisión Revisão	Issue date Data emissione Date d'émission Ausgabe-datum Fecha edición Data emissão	Review date Data revisione Date révision Vertatungs-datum Fecha revisión Data revisão	Edited by Redatto da Rédigé par Bearbeitet von Editado por Editado por	Endorsed Visto Vu Verm. Aprobación Assinatura
Technical Documentation	1-5302-865	02	01 / 2009	03 / 2026	M. Silvestrone	SERVICE DEPT.

Translated from the original manual in Italian language.

Data reported in this issue can be modified at any time by REHLKO.

This manual contains pertinent information regarding the repair of REHLKO Air Cooled, Direct Injection Diesel engines type **KD 441**: updated 30-03-2026

TABLE OF CONTENTS

1	GENERAL REMARKS AND SAFETY INFORMATION.....	8-9
	General safety during operating phases	9
	Safety and environmental impact.....	9
	Safety and warning decals	8
	Safety regulations	8
2	TECHNICAL INFORMATION	10-13
	Manufacturer and engine identifications	11
	Overall dimensions.....	13
	Technical data	12
	Trouble shooting.....	10
3	MAINTENANCE - RECOMMENDED OIL TYPE - REFILLING.....	14-17
	ACEA Regulations - ACEA Sequences	15
	API / MIL Sequences	15
	Engines oil capacity	16
	Extraordinary maintenance	14
	Fuel recommendations.....	17
	International specifications.....	15
	Lubricant	15
	Ordinary maintenance.....	14
	Prescribed lubricant	16
	Routine engine maintenance	14
	SAE Classification.....	15
4	DISASSEMBLY.....	18-31
	Camshaft.....	27
	Connecting rod.....	23
	Connecting rod - upward replacement of the connecting rod half bearings.....	25
	Crankshaft.....	28
	Cylinder	25
	Cylinder head	22
	Decompression lever, operation check	18
	Engine starting by means of a rope (emergency starting)	18
	Equalizer shaft	28
	Flywheel.....	26
	Fuel overflow system, Disassembly	21
	Fuelling/injection circuit.....	20
	Injector	22
	Oil pump.....	29
	Recommendations for disassembly	18
	Rocker arm cover.....	19
	Rocker arm cover - Breather ricirculation.....	19
	Rocker arm cover breather system	19
	Shroud.....	20
	Speed governor gear	28
	Start pulley	20
	Timing cover.....	27
5	OVERHAULS AND CHECKING	32-47
	Availability of bearings	40
	Camshaft.....	44
	Camshaft journals and bore	45
	Camshaft, cam height (mm).....	45
	Camshaft, pin and housing dimensions, and relevant clearances (mm)	45
	Connecting rod alignment	39
	Connecting rod, piston pin	38
	Crankcase bearing - Extraction.....	42
	Crankcase bearing - Reassembly	42
	Crankshaft - journal diameter (mm)	40
	Crankshaft - Main bearing, big end, and crankshaft bearing internal diameters, and relevant clearances.....	40

Crankshaft, connection radius.....	39
Crankshaft, journal/crankpin diameter check, timing cover bearing internal diameters and crankshaft and big end bearing support	39
Crankshaft, lubrication ducts, bore thread on flywheel side and p.t.o.....	39
Cylinder	37
Cylinder head.....	33
Cylinder roughness	37
Dimensions and clearance between guides and valve stems (mm)	34
Dynamic balancer (on request).....	45
Gearbox extension, bearing and oil seal replacement.....	43
Injector protrusion.....	37
Oil seal ring - Reassembly	44
Oil seal ring on crankcase - Reassembly.....	43
Piston	37
Piston rings, assembly order.....	38
Piston rings, distance between the tips (mm)	38
Piston rings, play between the slots (mm)	38
Recommendations for overhauls and checking	32
Roller bearing - Disassembly	43
Roller bearing - Reassembly.....	43
Shaft seals	32
Timing cover bearing - Disassembly	41
Timing cover bearing - Reassembly.....	41
Timing cover bearing, crankshaft bearing, and clearance shims replacement	41
Valve guides - Reassembly.....	35
Valve guides - Removal	35
Valve seat lapping	36
Valve seats - Reassembly.....	36
Valve seats - Removal	35
Valve timing - Angles.....	46
Valve, springs.....	33
Valves - Disassembly.....	33
Valves - Oil seal in valve guide	36
Valves - Reassembly.....	36
Valves seats and valve seat bores.....	34
Valves, characteristics.....	33
Valves, guide insertion	34
Valves, guides and housings.....	34
6 REASSEMBLY.....	48-57
Assessing head gasket thickness	55
Camshaft.....	51
Camshaft end play	54
Connecting rod big end cap	49
Connecting rod, tightening	50
Crankshaft	48
Crankshaft end play	54
Cylinder	49
Equalizer shaft	51
Flywheel.....	56
Gear cover on timing side	53
Gearbox extension	54
Gearbox extension, intermediate flange	54
Head gasket (mm).....	55
Head tightening	56
Injection pump and tappet fitting in the crankcase.....	50
Injector	57
Oil pump.....	51
Oil seals, crankshaft - Replacement	55
Piston	48
Piston protrusion check.....	55
Recommendations for reassembling.....	48
Rings	49
Rocker arm cover.....	57
Speed governor gear	52
Valve tappets.....	50
Valve/rocker arm clearance.....	57

7	LUBRICATION SYSTEM	58-61
	Internal strainer	59
	Lubrication system	58
	Oil pressure check	60
	Oil pressure curve at full rotation speed.....	60
	Oil pressure curve at idle rotation speed	60
	Oil pressure regulation valve.....	59
	Oil pump.....	59
	Oil pump - Clearance between rotors	59
8	FUEL SYSTEM	62-69
	Bar filter.....	68
	Conversion table from millimetres into degrees	67
	Fuel filter	62
	Fuel lift pump.....	62
	Fuel lift pump - Filter cleaning	63
	Fuel pump, drive rod protrusion	63
	Fuelling/injection circuit.....	62
	Injection advance adjustment.....	67
	Injection advance specified value	67
	Injection pump.....	64
	Injection pump components and disassembly	65
	Injection pump fitting in the crankcase	64
	Injection pump non-return valve.....	66
	Injection pump refitting.....	65
	Injection pump, body, plunger and delivery valve	65
	Injector	68
	Injector calibration	69
	Nozzles	69
	References on the flywheel.....	67
	Solenoid valve.....	64
	Static injection timing	66
9	ELECTRICAL SYSTEM	70-73
	12V, 17A electric ignition diagram	70
	Alternator.....	70
	Alternator charger graph (12V, 17A)	70
	Characteristic curves for starting motor type BOSCH DW (L) 12V, 1.2 KW.....	73
	Connection Diagram	71
	Ignition switch positions	73
	Starting motor - BOSCH	73
	Testing voltage regulator for proper operation	72
	Voltage regulator	71
10	ADJUSTMENTS	74-77
	Accelerator lever for speed governor with min/max speed system.....	74
	Assembly procedure for accelerator lever of speed governor with min/max speed system	74
	Injection pump delivery approximate setting.....	76
	Injection pump delivery limiting and torque adapter.....	76
	Injection pump delivery setting for engines with dynamometric brake	77
	Required settings (the most common ones)	77
	Setting the fast idle (standard) rotation speed	75
	Setting the slow idle (standard) rotation speed	75
11	STORAGE	78-79
	Engine storage.....	78
	Preparing the engine for operation after protective treatment.....	79
	Protective treatment.....	78
12	MAIN TORQUE SPECIFICATIONS AND USE OF SEALANTS	80-81
	Main torque specifications.....	80
	Table of tightening torques for standard screws (coarse thread).....	81
	Table of tightening torques for standard screws (fine thread)	81
	Use of sealant	80
13	SPECIAL TOOLS	82-83

SAFETY AND WARNING DECALS

- Important remarks and features of the text are highlighted using symbols, which are explained below:



Danger – Attention

This indicates situations of grave danger which, if ignored, may seriously threaten the health and safety of individuals.



Caution – Warning

This indicates that it is necessary to take proper precautions to prevent any risk to the health and safety of individuals and avoid financial damage.



Important

This indicates particularly important technical information that should not be ignored.

SAFETY REGULATIONS

Combustion creates carbon monoxide, an odourless and highly poisonous gas.

Lengthy stays in places where the engine freely exhausts this gas can lead to unconsciousness and death.

- The engine must not operate in places containing inflammable materials, in explosive atmospheres, where there is dust that can easily catch fire unless specific, adequate and clearly indicated precautions have been taken and have been certified for the machine.
- To prevent fire hazards, always keep the machine at least one meter from buildings or from other machinery.
- Children and animals must be kept at a due distance from operating machines in order to prevent hazards deriving from their operation.
- Fuel is inflammable.
The tank must only be filled when the engine is off.
Thoroughly dry any spilled fuel and move the fuel container away along with any rags soaked in fuel or oil.
Make sure that no soundproofing panels made of porous material are soaked in fuel or oil.
Make sure that the ground or floor on which the machine is standing has not soaked up any fuel or oil.
- Fully tighten the tank plug each time after refuelling.
Do not fill the tank right to the top but leave an adequate space for the fuel to expand.
- Fuel vapour is highly toxic.
Only refuel outdoors or in a well ventilated place.
- Do not smoke or use naked flames when refuelling.
- The engine must be started in compliance with the specific instructions in the operation manual of the engine and/or machine itself.
Do not use auxiliary starting aids that were not installed on the original machine (e.g. Startpilot').
- Before starting, remove any tools that were used to service the engine and/or machine.
Make sure that all guards have been refitted.
- During operation, the surface of the engine can become dangerously hot.
Avoid touching the exhaust system in particular.
- Before proceeding with any operation on the engine, stop it and allow it to cool.
Never carry out any operation whilst the engine is running.
- The coolant fluid circuit is under pressure.
Never carry out any inspections until the engine has cooled and even in this case, only open the radiator plug or expansion chamber with the utmost caution, wearing protective garments and goggles. If there is an electric fan, do not approach the engine whilst it is still hot as the fan could also start operating when the engine is at a standstill.
Only clean the coolant system when the engine is at a standstill.
- When cleaning the oil-cooled air filter, make sure that the old oil is disposed of in the correct way in order to safeguard the environment.
The spongy filtering material in oil-cooled air filters must not be soaked in oil.
The reservoir of the separator pre-filter must not be filled with oil.
- The oil must be drained whilst the engine is hot (oil T ~ 80°C).
Particular care is required to prevent burns.
Do not allow the oil to come into contact with the skin.
- Pay attention to the temperature of the oil filter when the filter itself is replaced.
- Only check, top up and change the coolant fluid when the engine is off and cold.
Take care to prevent fluids containing nitrites from being mixed with others that do not contain these substances since "Nitrosamine", dangerous for the health, can form.
The coolant fluid is polluting and must therefore be disposed off in the correct way to safeguard the environment.
- During operations that involve access to moving parts of the engine and/or removal of rotating guards, disconnect and insulate the positive wire of the battery to prevent accidental short-circuits and to stop the starter motor from being energized.
- Only check belt tension when the engine is off.
- Only use the eyebolts installed by **REHLKO** to move the engine.
These lifting points are not suitable for the entire machine; in this case, the eyebolts installed by the manufacturer should be used.

- **REHLKO** Engines are built to supply their performances in a safe and long-lasting way.
To obtain these results, it is essential for users to comply with the servicing instructions given in the relative manual along with the safety recommendations listed below.
- The engine has been made according to a machine manufacturer's specifications and all actions required to meet the essential safety and health safeguarding requisites have been taken, as prescribed by the current laws in merit.
All uses of the engine beyond those specifically established cannot therefore be considered as conforming to the use defined by **REHLKO** which thus declines all liability for any accidents deriving from such operations.
- The following indications are dedicated to the user of the machine in order to reduce or eliminate risks concerning engine operation in particular, along with the relative routine maintenance work.
- The user must read these instructions carefully and become familiar with the operations described.
Failure to do this could lead to serious danger for his personal safety and health and that of any persons who may be in the vicinity of the machine.
- The engine may only be used or assembled on a machine by technicians who are adequately trained about its operation and the deriving dangers.
This condition is also essential when it comes to routine and, above all, extraordinary maintenance operations which, in the latter case, must only be carried out by persons specifically trained by **REHLKO** and who work in compliance with the existing documentation.
- Variations to the functional parameters of the engine, adjustments to the fuel flow rate and rotation speed, removal of seals, demounting and refitting of parts not described in the operation and maintenance manual by unauthorized personnel shall relieve **REHLKO** from all and every liability for deriving accidents or for failure to comply with the laws in merit.
- On starting, make sure that the engine is as horizontal as possible, unless the machine specifications differ.
In the case of manual start-ups, make sure that the relative actions can take place without the risk of hitting walls or dangerous objects, also considering the movements made by the operator.
Pull-starting with a free cord (thus excluding self-winding starting only), is not permitted even in an emergency.
- Make sure that the machine is stable to prevent the risk of overturning.
- Become familiar with how to adjust the rotation speed and stop the engine.
- Never start the engine in a closed place or where there is insufficient ventilation.

GENERAL SAFETY DURING OPERATING PHASES

- The procedures contained in this manual have been tested and selected by the manufacturer's technical experts, and hence are to be recognised as authorised operating methods.
- A number of procedures must be carried out with the aid of equipment and tools that simplify and improve the timing of operations.
- All tools must be in good working condition so that engine components are not damaged and that operations are carried out properly and safely.
It is important to wear the personal safety devices prescribed by work safety laws and also by the standards of this manual.
- Holes must be lined up methodically and with the aid of suitable equipment. Do not use your fingers to carry out this operation to avoid the risk of amputation.
- Some phases may require the assistance of more than one operator. If so, it is important to inform and train them regarding the type of activity they will be performing in order to prevent risks to the health and safety of all persons involved.
- Do not use flammable liquids (petrol, diesel, etc.) to degrease or wash components. Use special products.
- Use the oils and greases recommended by the manufacturer.
Do not mix different brands or combine oils with different characteristics.
- Discontinue use of the engine if any irregularities arise, particularly in the case of unusual vibrations.
- Do not tamper with any devices to alter the level of performance guaranteed by the manufacturer.

SAFETY AND ENVIRONMENTAL IMPACT

Every organisation has a duty to implement procedures to identify, assess and monitor the influence of its own activities (products, services, etc.) on the environment.
Procedures for identifying the extent of the impact on the environment must consider the following factors:

- Liquid waste
- Waste management
- Soil contamination
- Atmospheric emissions
- Use of raw materials and natural resources
- Regulations and directives regarding environmental impact

In order to minimise the impact on the environment, the manufacturer now provides a number of indications to be followed by all persons handling the engine, for any reason, during its expected lifetime.

- All packaging components must be disposed off in accordance with the laws of the country in which disposal is taking place.
- Keep the fuel and engine control systems and the exhaust pipes in efficient working order to limit environmental and noise pollution.
- When discontinuing use of the engine, select all components according to their chemical characteristics and dispose of them separately.

TROUBLE SHOOTING

THE ENGINE MUST BE STOPPED IMMEDIATELY WHEN:

- 1) - The engine rpms suddenly increase and decrease;
- 2) - A sudden and unusual noise is heard;
- 3) - The colour of the exhaust fumes suddenly darkens;
- 4) - The oil pressure indicator light turns on while running.

TABLE OF LIKELY ANOMALIES AND THEIR SYMPTOMS

The following table contains the possible causes of some failures which may occur during operation. Always perform these simple checks before removing or replacing any part.

POSSIBLE CAUSE		TROUBLE									
		Engine does not start	Engine starts but stops	No acceleration	Non-uniform speed	Black smoke	White smoke	Too low oil pressure	Increase oil level	Excessive oil consumption	oil and fuel dripping from exhaust
FUEL SYSTEM	Clogged pipes										
	Clogged fuel filter										
	Air inside fuel circuit										
	Clogged tank breather hole										
	Faulty fuel pump										
	Fuel pump filter clogged										
	Injector jammed										
	Jammed injection pump delivery valve										
	Wrong injector setting										
	Excessive plunger blow-by										
	Jammed injection pump delivery control										
	Wrong injection pump setting										
LUBRICATION SYSTEM	Oil level too high										
	Jammed pressure relief valve										
	Worn oil pump										
	Air inside oil suction pipe										
	Faulty pressure gauge or switch										
	Clogged oil suction pipe										
ELECTRIC SYSTEM	Battery discharged										
	Wrong or inefficient cable connection										
	Defective ignition switch										
	Defective starter motor										
MAINTENANCE	Clogged air filter										
	Excessive idle operation										
	Incomplete running-in										
	Engine overloaded										
DISASSEMBLY/REASSEMBLY SETTINGS	Advanced injection										
	Delayed injection										
	Incorrect governor linkage adjustment										
	Broken or loose governor spring										
	Idle speed too low										
	Worn or jammed piston rings										
	Worn or scored cylinders										
	Worn valve guides										
	Jammed valves										
	Worn bearings										
	Governor linkage not free to slide										
	Drive shaft not free to slide										
Damaged cylinder head gasket											

MANUFACTURER AND ENGINE IDENTIFICATION

The identification plate shown in the figure can be found directly on the engine.

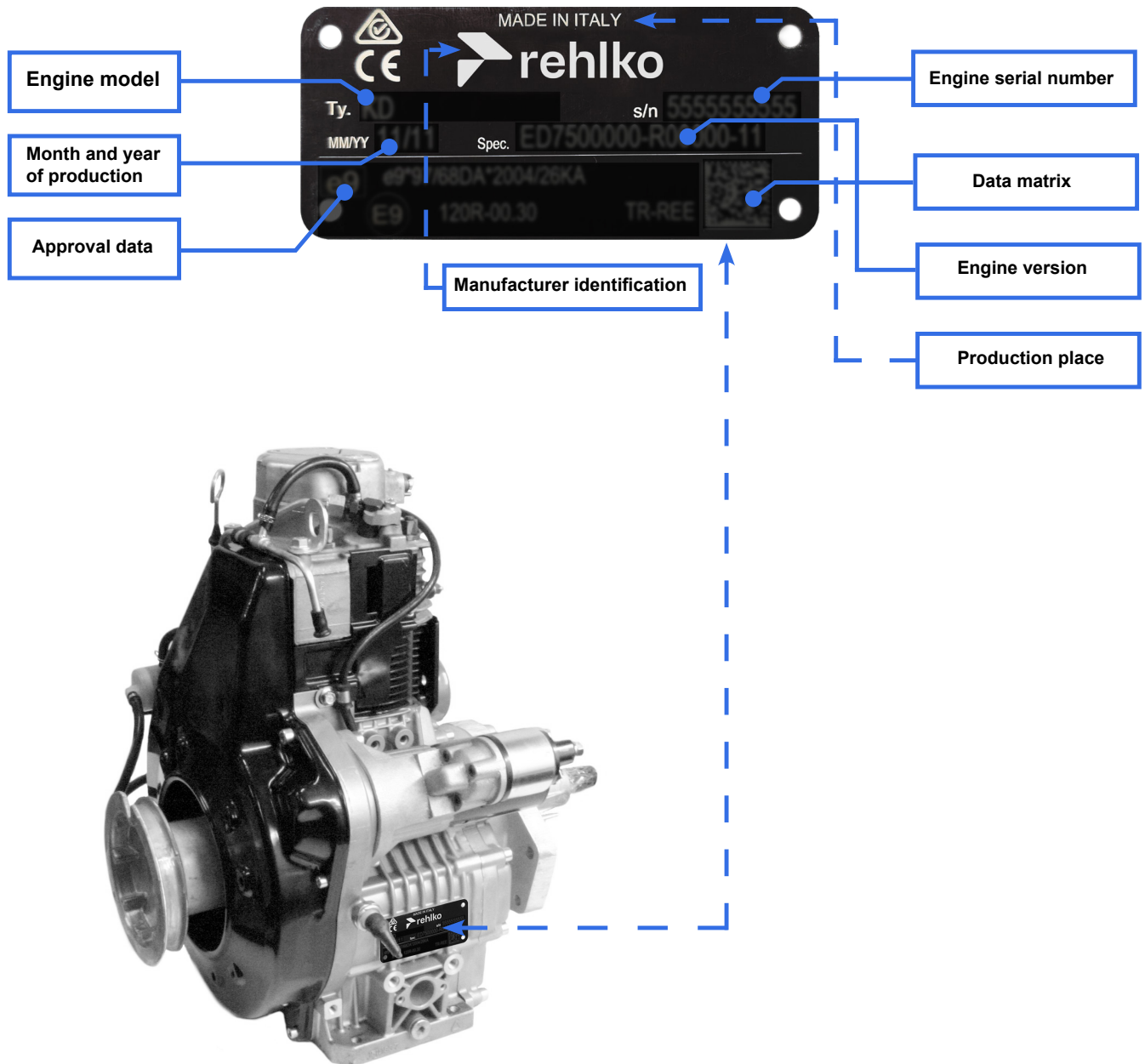

TECHNICAL DATA

ENGINE TYPE		KD 441
Number of cylinders	N.	1
Bore	mm	86
Stroke	mm	76
Swept volume	Cm ³	441
Compression ratio		20.5:1
R.P.M.		3600
Power kW (HP)	N 80/1269/EEC-ISO 1585	6.8
	NB ISO 3046 - 1 IFN	6.6(9.0)
	NA ISO 3046 - 1 ICXN	6.2(8.4)
Max. torque *	Nm	21@2200
Fuel consumption **	g/kW.h	273
Oil consumption	l/h	0.0044
Capacity of standard oil sump	lt	1.5
Recommended battery	V/Ah	12/44
Dry weight	kg	51
Combustion air volume at 3600 r.p.m.	l./min	580
Cooling air volume at 3600 r.p.m.	l./min	5500
Max.permissible driving shaft axial load in both directions	kg.	200
Max. inclination	continuous service for up to 30 min.	25°
	discontinuous service for about 1 min.	35°
	permanent service	***

* Referred to N power

** Referred to NB power

*** Depending on the application

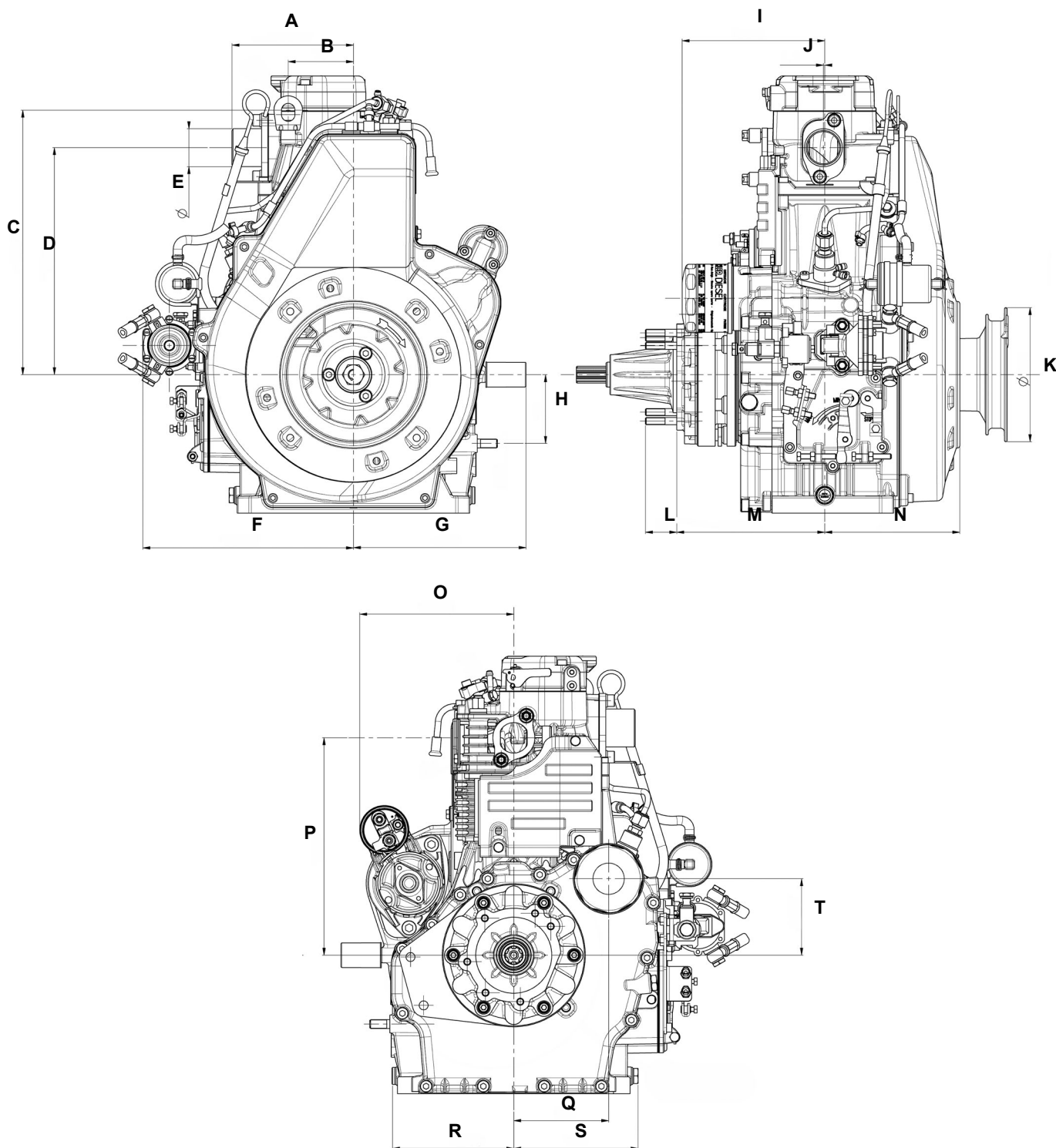
OVERALL DIMENSIONS

DIMENSIONS mm									
A	135.8	E	42.4	I	159.5	M	165.5	Q	106
B	73	F	235.5	J	1.5	N	151	R	135.5
C	296	G	193	K	150	O	172.2	S	139
D	254	H	77	L	35	P	243	T	85.5

ROUTINE ENGINE MAINTENANCE

Caution – Warning

Failure to carry out the operations described in the table may lead to technical damage to the machine and/or system

EXTRAORDINARY MAINTENANCE

OPERATION	ITEM	Interval Km
		After the first 1000 km
CHECK	Check the valves gap	
REPLACEMENT	Oil filter	
	Engine oil	

ORDINARY MAINTENANCE

OPERATION	ITEM	Maintenance interval at Km							
		1.000	5.000	10.000	20.000	30.000	70.000	100.000	
CLEANING	Dry air-cleaner								
	Cylinder cooling fins								
	Fuel filter - primary								
CHECK	Lube oil level								
	Valves gap								
	Water presence in the fuel filter								
	Fuel lines pipes								
	Injector and fuel injection pump								
	Idling speed								
REPLACEMENT	Lube oil								
	Oil filter								
	Fuel filter primary								
	Fuel filter - secondary								
	Dry air filter cartridge								
OVERHAUL	General overhaul								

LUBRICANT
SAE Classification

In the SAE classification, oils differ on the basis of their viscosity, and no other qualitative characteristic is taken into account.

The first number refers to the viscosity when the engine is cold (symbol W = winter), while the second considers viscosity with the engine at régime.

The criteria for choosing must consider, during winter, the lowest outside temperature to which the engine will be subject and the highest functioning temperature during summer.

Single-degree oils are normally used when the running temperature varies scarcely.

Multi-degree oil is less sensitive to temperature changes.

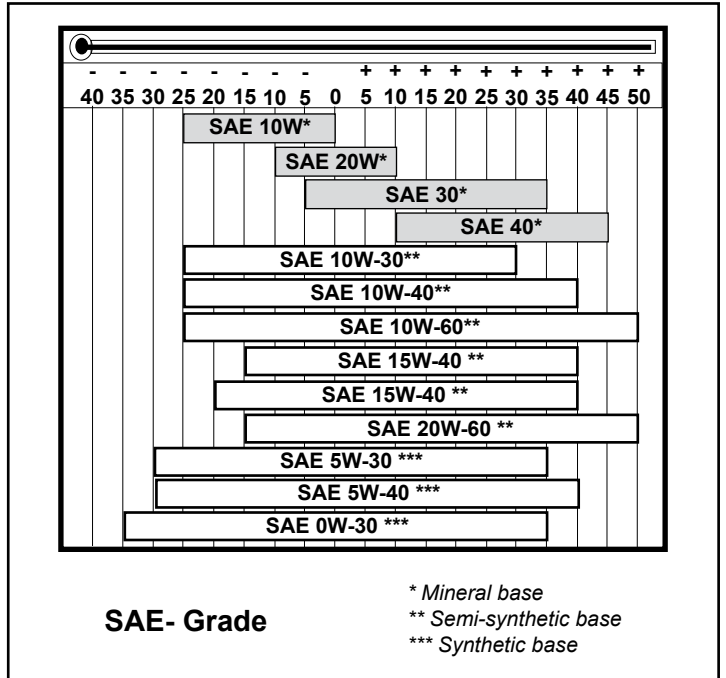

REHLKO X-treme 10W-40 Formula Pro; X-treme 10W-40; X-treme 5W-40 oil are preferred.

International specifications

They define testing performances and procedures that the lubricants need to successfully respond to in several engine testing and laboratory analysis so as to be considered qualified and in conformity to the regulations set for each lubrication kind.

A.P.I : (American Petroleum Institute)

MIL : Engine oil U.S. military specifications released for logistic reasons

ACEA : European Automobile Manufacturers Association

Tables shown on this page are of useful reference when buying a kind of oil.

Codes are usually printed-out on the oil container and the understanding of their meaning is useful for comparing different brands and choosing the kind with the right characteristics.

Usually a specification showing a following letter or number is preferable to one with a preceding letter or number.

An SF oil, for instance, is more performing than a SE oil but less performing than a SG one.

PRESCRIBED LUBRICANT
ACEA Regulations - ACEA Sequences
LIGHT DUTY DIESEL ENGINES

B1 = Low-viscosity, for frictions reduction
 B2 = Standard
 B3 = High performances (indirect injection)
 B4 = High quality (direct injection)

HEAVY DUTY DIESEL ENGINES

E1 = OBSOLETE
 E2 = Standard
 E3 = Heavy conditions (Euro 1 - Euro 2 engines)
 E4 = Heavy conditions (Euro 1 - Euro 2 - Euro 3 engines)
 E5 = High performances in heavy conditions (Euro 1 - Euro 2 - Euro 3 engines)

API / MIL Sequences

DIESEL								
API	CH-4	CG-4	CF-4	CF-2	CF	CE	CD	CC
MIL								
			L- 46152			D / E		
CORRENTI		CURRENT		OBSOLETI		OBSOLETE		

REHLKO X-TREME 10W-40 FORMULA PRO X-TREME 10W-40 X-TREME 5W-40	specifications	API CF- 4 ACEA B2 - E2 MIL - L-46152 D/E
---	----------------	---

Alternatively, use oil API CF/SH for Diesel engines or oil corresponding to the military specification MIL-L-2104 C/46152 D.

ENGINES OIL CAPACITY

OIL VOLUME AT MAX LEVEL	Litres	1.5
-------------------------	--------	------------

Danger – Attention

- The engine may be damaged if operated with insufficient lube oil. It is also dangerous to supply too much lube oil to the engine because a sudden increase in engine rpm could be caused by its combustion.
- Use proper lube oil preserve your engine. Good quality or poor quality of the lubricating oil has an affect on engine performance and life.
- If inferior oil is used, or if your engine oil is not changed regularly, the risk of piston seizure, piston ring sticking, and accelerated wear of the cylinder liner, bearing and other moving components increases significantly.
- Always use oil with the right viscosity for the ambient temperature in which your engine is being operated.

Danger – Attention

- The used engine oil can cause skin-cancer if kept frequently in contact for prolonged periods.
- If contact with oil cannot be avoided, wash carefully your hands with water and soap as soon as possible.
- Do not disperse the oil in the ambient, as it has a high pollution power.

FUEL RECOMMENDATIONS

Purchase diesel fuel in small quantities and store in clean, approved containers. Clean fuel prevents the diesel fuel injectors and pumps from clogging. Do not overfill the fuel tank.

Leave room for the fuel to expand. Immediately clean up any spillage during refueling.

Never store diesel fuel in galvanized containers; diesel fuel and the galvanized coating react chemically to each other, producing flaking that quickly clogs filters or causes fuel pump or injector failure.

High sulfur content in fuel may cause engine wear. In those countries where diesel has a high sulfur content, it is advisable to lubricate the engine with a high alkaline oil or alternatively to replace the lubricating oil recommended by the manufacturer more frequently. The regions in which diesel normally has a low sulfur content are Europe, North America, and Australia.

PRESCRIBED LUBRICANT	
Fuel with low sulphur content	API CF4 - CG4
Fuel with high sulphur content	API CF

FUEL TYPE

For best results, use only clean, fresh, commercial-grade diesel fuel. Diesel fuels that satisfy the following specifications are suitable for use in this engine: ASTM D-975 - 1D or 2D, EN590, IS 1460 or equivalent.

FUELS FOR LOW TEMPERATURES

It is possible to run the engine at temperatures below 0°C using special winter fuels. These fuels reduce the formation of paraffin in diesel at low temperatures. If paraffin forms in the diesel, the fuel filter becomes blocked interrupting the flow of fuel.

Fuel can be:

- Summer up to 0°C
- Winter up to -10°C
- Alpine up to -20°C
- Arctic up to -30°C

BIODIESEL FUEL

Fuels containing less than 20% methyl ester or B20, are suitable for use in this engine. Biodiesel fuels meeting the specification of BQ-9000, EN 14214 or equivalent may be used. DO NOT use vegetable oil as a biofuel for this engine.

Any failures resulting from the use of fuels other than recommended will not be warranted.

AVIATION FUEL

Aviation fuels suitable for use in this engine include JP5, JP4, JP8 and, JET-A (if 5 percent oil is added).

RECOMMENDATIONS FOR DISASSEMBLY



Important



Caution – Warning

To locate specific topics, the reader should refer to the index.

- Before any intervention, the operator should lay out all equipment and tools in such a way as to enable him to carry out operations correctly and safely.
- Before proceeding with operations, make sure that appropriate safety conditions are in place, in order to safeguard the operator and any persons involved.
- For safety and convenience, you are advised to place the engine on a special rotating stand for engine overhauls.

Please remember that any variation in the intake system during the application phase of KD 441 engines involves series anomalies to the engines for every variations to functional system.

Optimisation must be carried out beforehand at REHLKO testing centres. Non-approval by REHLKO of any modifications, releases the company from any damages incurred by the engine.

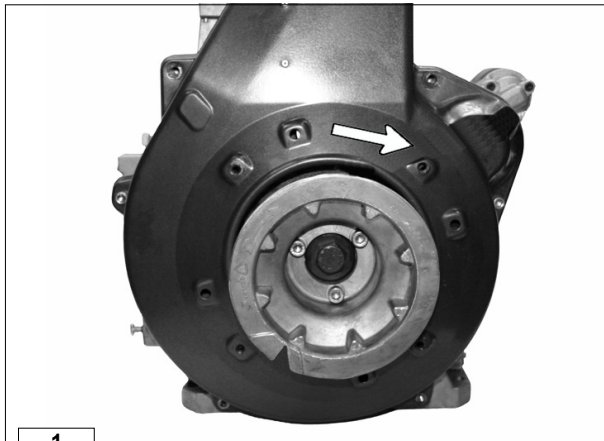

1

Decompression lever, operation check

Manually rotate the pulley clockwise up to the compression point.

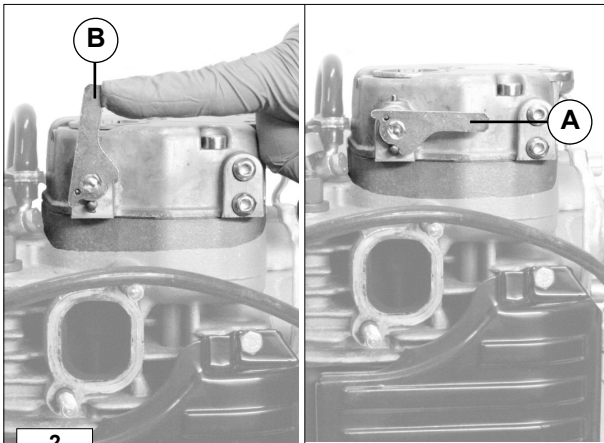

2

Operate the decompression lever by moving it up to position **B**. Check the proper functioning of the decompression lever as described in the following operations:

After bringing the engine at the T.D.C., check that the lever is in position **B**. The semiautomatic decompression lever should automatically return to resting position **A** by manually rotating the engine clockwise.



3

Engine starting by means of a rope (emergency starting)

Manually rotate the pulley clockwise up to the compression point. Operate the decompression lever by moving it up to position **B**. Place the knot of the rope in the appropriate space (see figure). Wind the rope on the pulley clockwise.

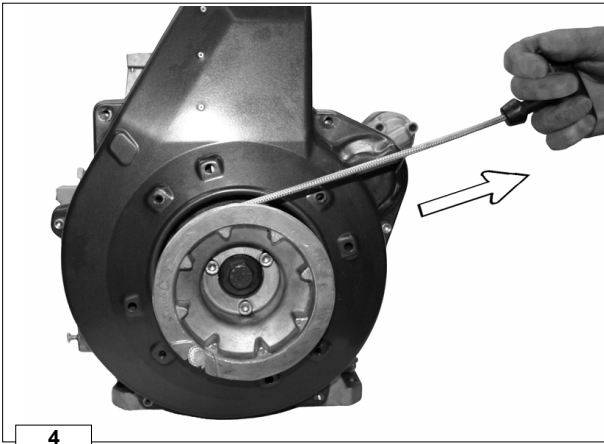

4

Hold the grip and firmly pull out the rope to start.

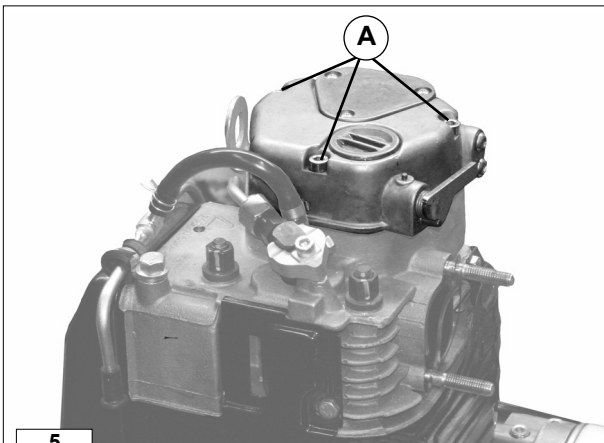

5

Rocker arm cover

Loosen fastening screws **A** and remove the rocker arm cover.

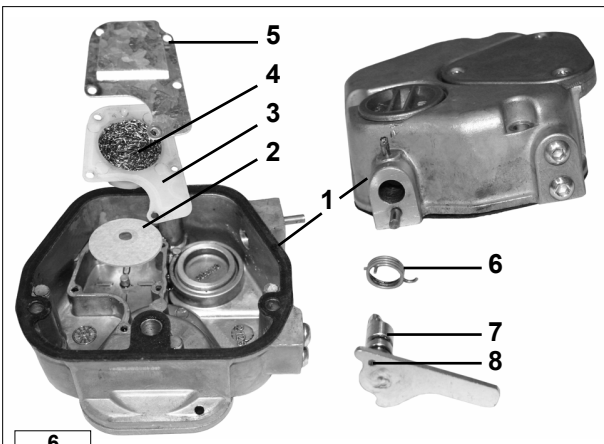

6

Rocker arm cover breather system

The crankcase breather system is located inside the rocker arm cover **1**. Check that diaphragm **2** is intact ; wash with Diesel oil and blow through the small mesh element **4** with compressed air. When reassembling fix box **3** with Loctite " Form-a- gasket No. 6" and screw plate **5**. To assemble decompression lever **7**, insert spring **6** (positioned as in figure) on the lever pin, considering that the spring clip should be inserted in hole **8**.

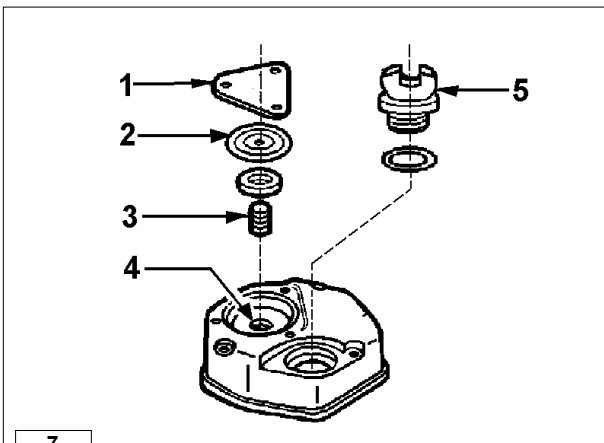

7

Rocker arm cover - Breather recirculation

⚠ Caution – Warning
Always check the the spring **3** and valve **2** to make sure they are in a good conditions.

Crankcase vapor recirculation occurs through duct **4**. If the air filter clogs, the increased intake vacuum could suck oil through duct **4** into the combustion chamber, causing the engine to operate at a runaway rate. This is prevented by valcuum valve **2** which, when the vacuum increases, overcomes the resistance of spring **3** and shuts the duct **4**. Make sure that oil plug **5** is correctly closed. Refit cover **1** and tighten rocker arm cover to 10 Nm.

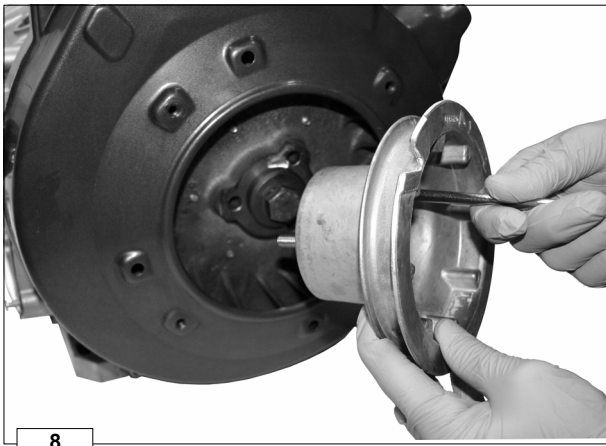

Start pulley

Loosen the 3 fastening screws and remove the pulley.

- When reassembling, tighten the screws to 23 Nm.

8

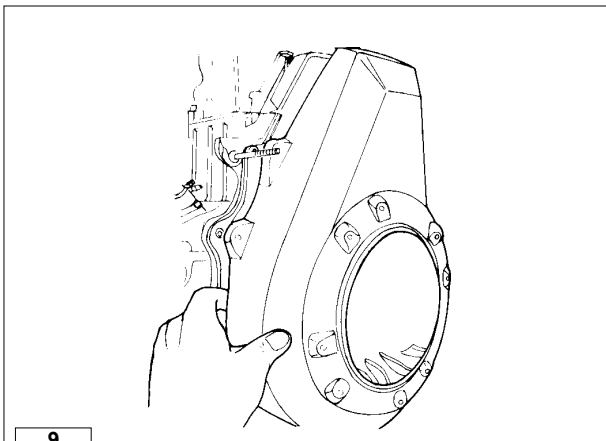

Shroud

Loosen the fastening screws and remove the conveyor.

- When refitting tighten shroud screws to 10 Nm.

9

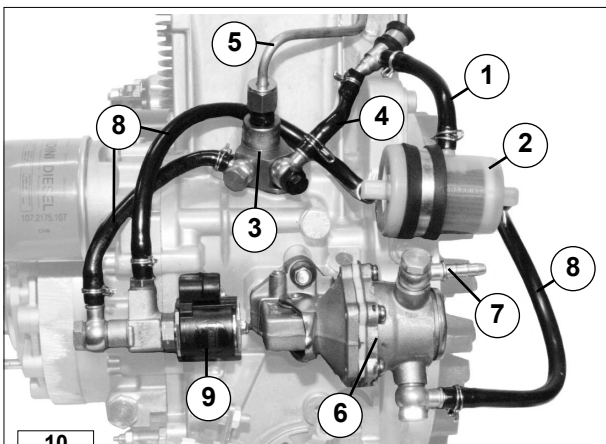

Fuelling/injection circuit

Components:

- 1 Fuel filter return tube
- 2 Fuel filter
- 3 Injection pump
- 4 Injector pump exhaust pipe
- 5 High pressure line
- 6 Fuel lift pump
- 7 Fuel pump suction (to be connected to the tank)
- 8 Fuel feeding tubes
- 9 Solenoid valve

10

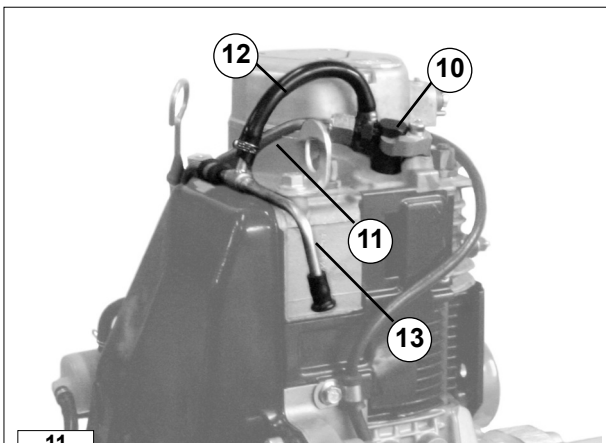

- 10 Injector
- 11 High pressure line
- 12 Injector leak-off line
- 13 Main fuel overflow pipe (to be connected to the tank)

11



12

Fuel overflow system, Disassembly

Loosen the outlet union of the injection pump and remove it.



13

Loosen and remove the support screw of the main fuel overflow pipe.



14

Remove the injector exhaust pipe from the main fuel overflow pipe.

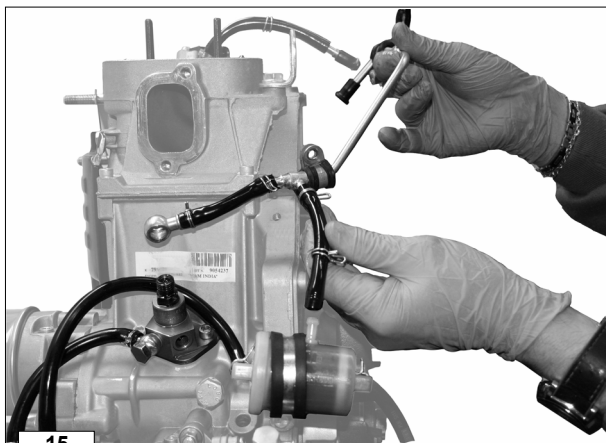

15

Disconnect the diesel fuel filter exhaust pipe and remove the whole fuel overflow pipe.

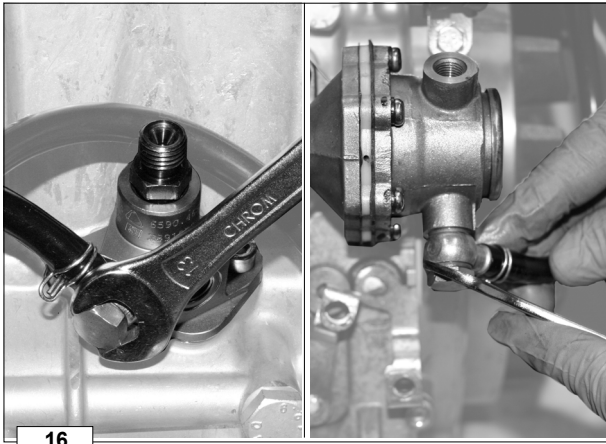

Loosen the inlet union of the injection pump.
Loosen the outlet union of the injection pump.

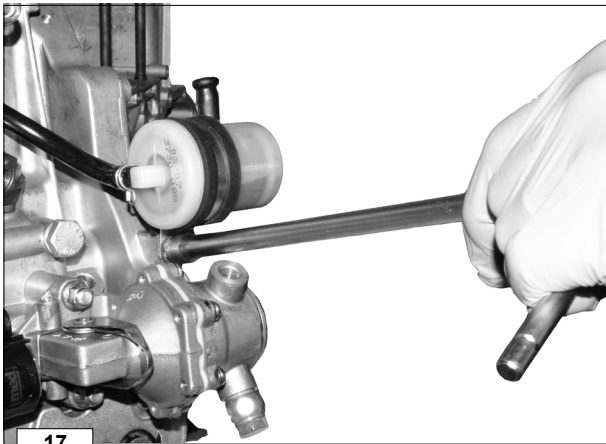

Loosen the fastening screw between the diesel fuel filter and the solenoid valve.
Remove the fuel supply circuit complete with solenoid valve, filter and fuel pump.

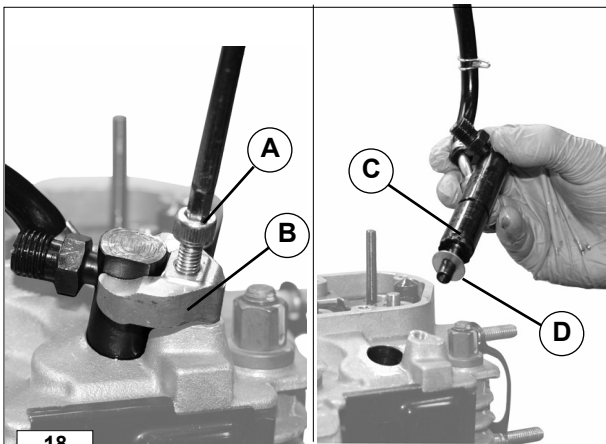

Injector

Loosen screw **A** and remove the bracket fixing injector **B** to the cylinder head.
Remove injector **C** together with copper seal **D**.

Important **Caution - Warning**

The correct protrusion of the spray nozzle from the cylinder head surface is obtained with copper seal **D** available in the following thicknesses: 0.5, 1 and 1.5 mm.

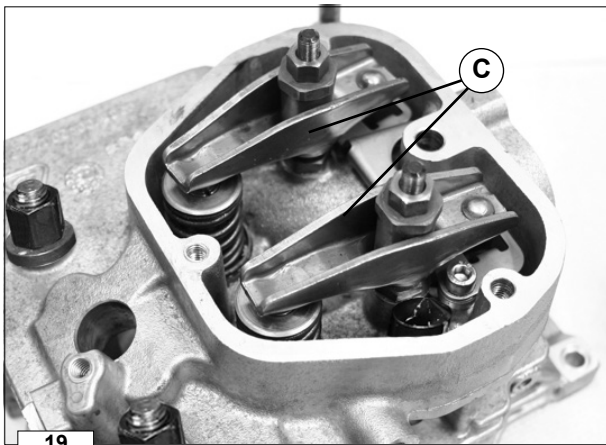

Cylinder head

Caution - Warning

Before disassembling the cylinder head, remove rocker arms **C** and the pushrods.

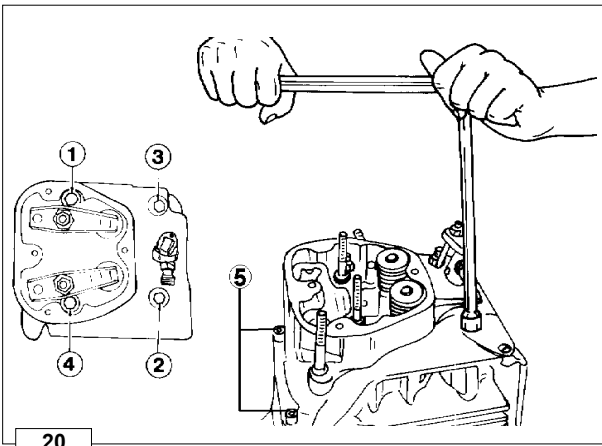

20



Caution – Warning

Do not demount when hot or the part could be deformed.

Loosen the four nuts and remove the cylinder head.
If the cylinder head surface is distorted, level it by removing up to 0.2 mm thickness.
Always replace the seal, see fig. 130-131 on page 55 for the correct thickness.
For overhaul and cylinder head checks, see page 33

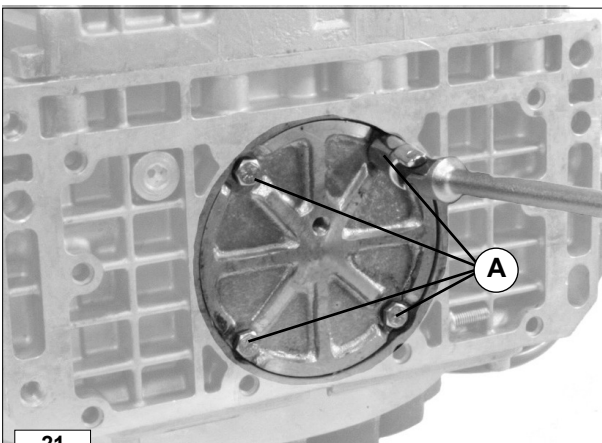

21

Connecting rod

Loosen the 4 fastening screws **A** of the bottom cap.

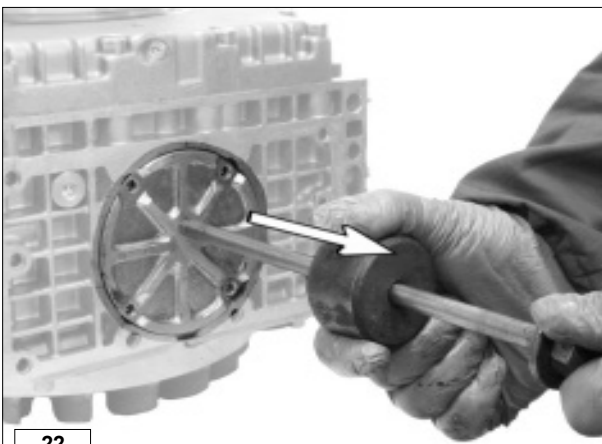

22

Tighten the hammer puller in the central hole and remove the bottom cap.

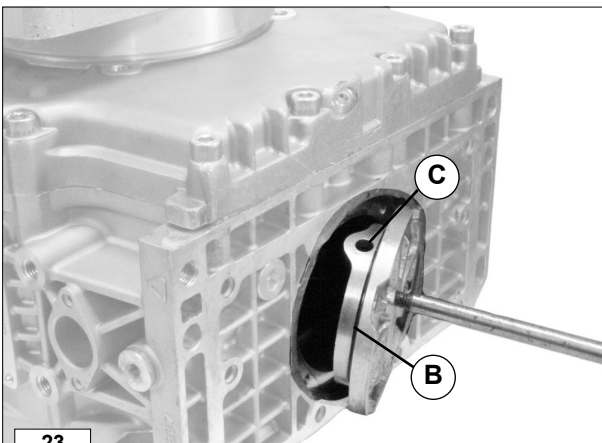

23

Remove the bottom cap.



Caution – Warning

When reassembling the cap, replace sealing O-ring **B and make sure that hole **C** is facing towards the timing system housing side.**

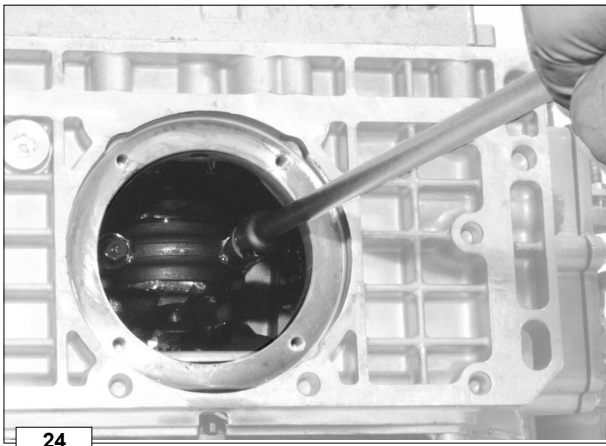

Place the piston to the B.D.C..
Loosen the screws of the cap on the connecting rod big end.

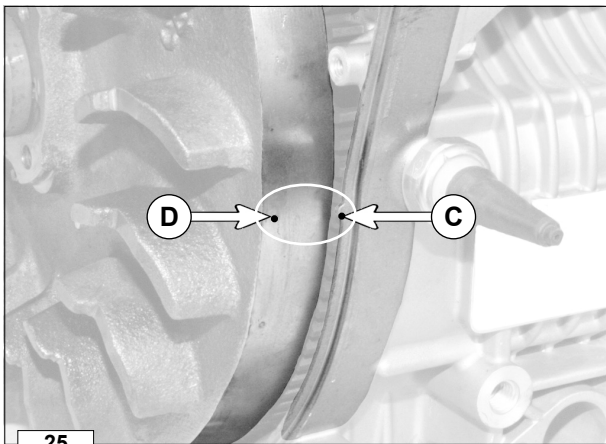

Rotate the crankshaft to T.D.C. position, until flywheel reference **D** is aligned with **C** on the crankcase.

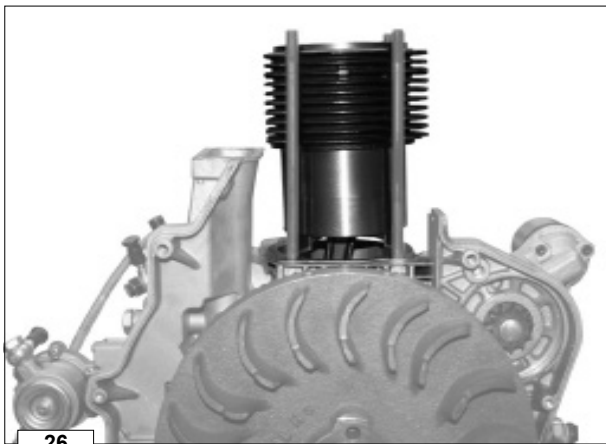

In T.D.C. position, the cylinder and the piston will be lifted as shown in the figure.

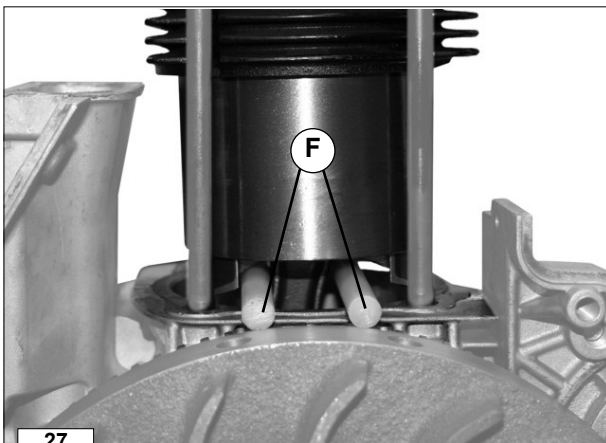

Insert the two nylon bars **F** under the cylinder to prevent the piston from being lowered.
Rotate the crankshaft to B.D.C. position to disconnect the cap on the connecting rod big end from the centering pins of the connecting rod.



Remove the cap on the connecting rod big end using the unthreaded part of the special tool p/n 1460-340.

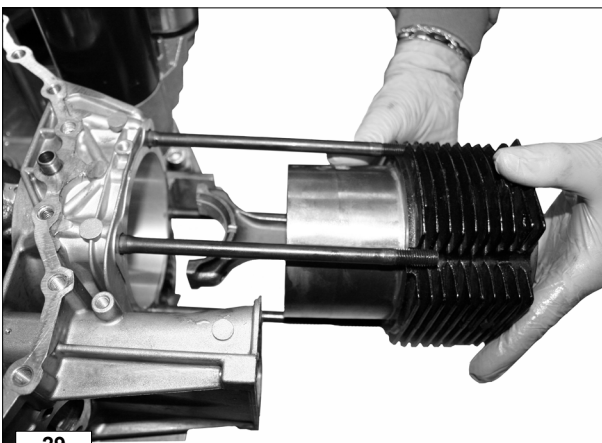

Cylinder

After removing the connecting rod cap, remove the cylinder, piston and connecting rod assembly from its seat. Remove the piston and the connecting rod from the cylinder by manually pushing the piston downwards with respect to the cylinder.

For dimensional checks of the connecting rod, piston and cylinder assembly see pages 37-38.

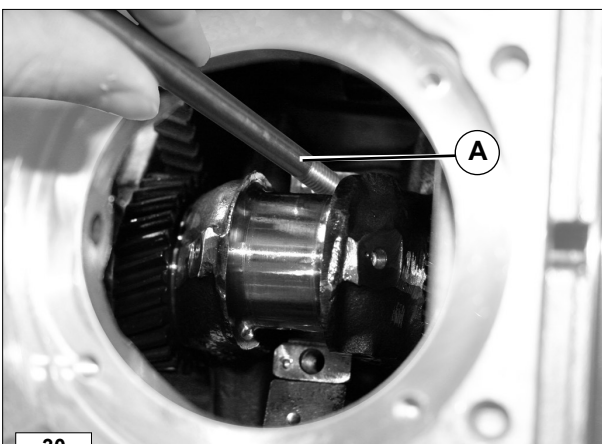

Connecting rod - upward replacement of the connecting rod half bearings

If necessary, it is possible to replace only the connecting rod half bearings without disassembling the connecting rod and the cylinder head assembly.

- 1- Remove the bottom cap (fig. 21-22-23)
- 2- Position the crankshaft to the B.D.C.
Remove the connecting rod cap screws (fig. 24)
- 3- Insert the special tool p/n 1460-340, unthreaded part first, replacing the screws on the cap.
- 4- After forcing carefully the two bars of the special tool to the right and to the left, disconnect the connecting rod cap from the shaft and remove it (fig. 28).
- 5- Tighten threaded bar **A** of the special tool in the threading of the connecting rod shaft (fig. 30).
- 6- Operate the decompression lever on the rocker arm cover to reduce compression resistance.
Push the connecting rod inwards so as to disconnect it from the crankshaft.
- 7- Rotate the crankshaft to release the connecting rod.
- 8- Using a nylon bar, keep the connecting rod shaft lifted and move the bar of the special tool from the upper hole to the lower hole.



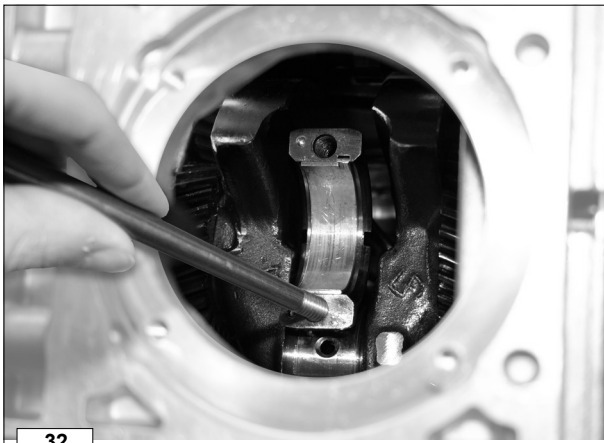

9- Pull the bar outwards so as to place the connecting rod shaft on the crankshaft and make the upper connecting rod half bearing accessible.



10- Using the nylon bar, push on a half bearing side and disconnect it.
 11- Using a magnet, remove the half bearing, taking care not to make it fall inside the engine.
 12- When reassembling, correctly place the half bearing in its seat. If necessary, push it with a nylon bar to avoid damages.
 13- Generously lubricate the half bearing and the connecting rod pin.
 14- Push the connecting rod upwards using the bar of the special tool to replace it in its seat on the connecting rod pin of the crankshaft.



15- Replace the half bearing of the connecting rod cap
 16- Reassemble the connecting rod cap after lubricating it generously.
 17- Tighten the screws alternately to a torque of 35 Nm.

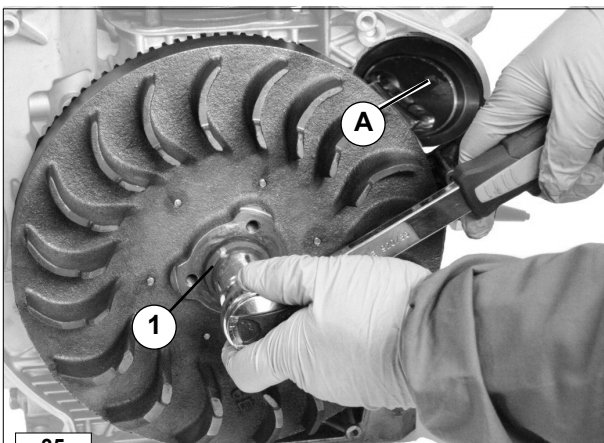

Flywheel

! Danger – Attention

During the demounting phases, pay particular attention to prevent the flywheel from dropping as this could seriously injure the operator.

Wear protective goggles when removing the flywheel ring.

Remove the starting motor and assemble special tool **A** p/n 1460-330 in its housing to lock the rotation of the flywheel.

Unscrew bolt **1** in a clockwise direction.

Remove the flywheel with a puller p/n° 1460-120.

Make sure that the tapered surface that couples to the drive shaft is not damaged.

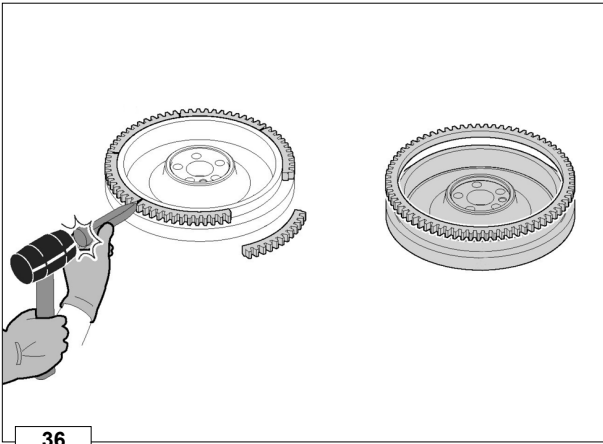

36

To remove the starter rim, it is advisable to cut it into several parts with a hacksaw and to then use a chisel. To replace, slowly heat for 15-20 minutes to a temperature of 300°C max. Fit the rim into the flywheel housing. make sure that it rests evenly against the support of the housing itself. Allow it to slowly cool.

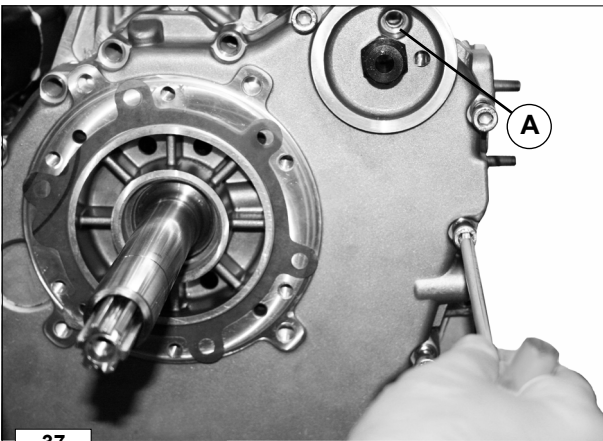

37

Timing cover

Disassemble the oil filter cartridge. Loosen the fastening screws of the timing cover including screw **A** housed in the seat of the oil filter cartridge.

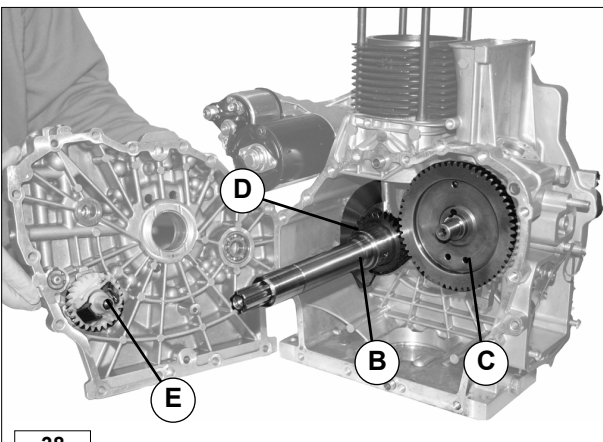

38

Components:

- B** Crankshaft
- C** Camshaft
- D** Equalizer shaft
- E** Speed governor / oil pump gear.



39

Camshaft

Remove camshaft **C**.

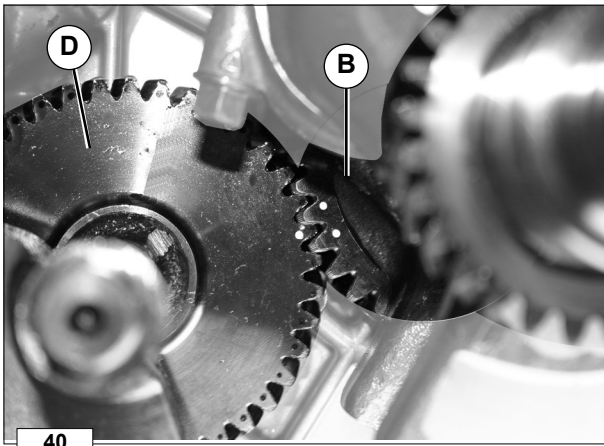

Equalizer shaft

Rotate crankshaft **B** to remove equalizer shaft **D**.

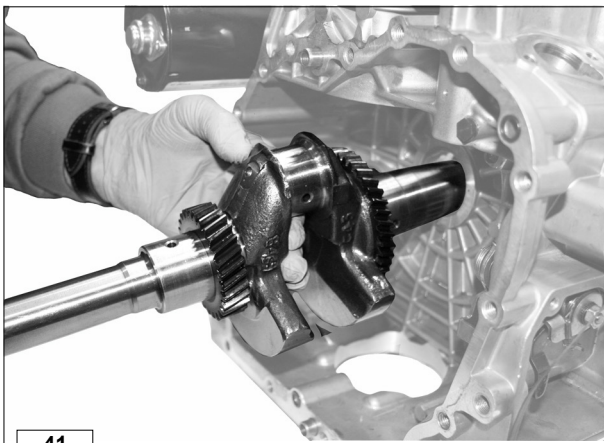

Crankshaft

Remove the crankshaft.

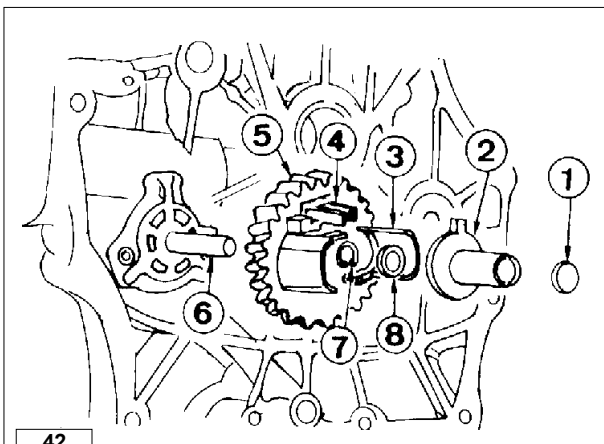

Speed governor gear

Components:

- 1 Spool spacer
- 2 Spool
- 3 Weights
- 4 Spool guide
- 5 Gear
- 6 Oil pump driving shaft
- 7 Circlip
- 8 Thrust ring

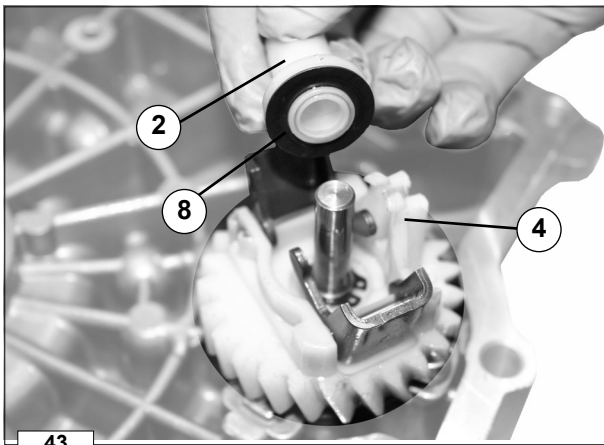

Remove drive rod **2** forcing the clamping teeth on rod collar **4** and the clearance shim **8**.

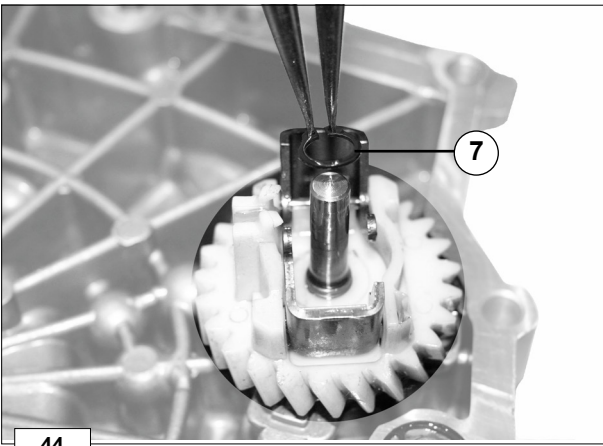

Remove governor lock tension washer 7.

44

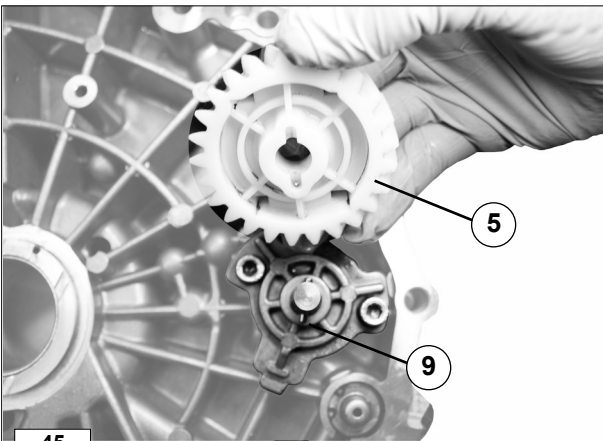

Remove governor gear 5 taking care not to make drive pin 9 drop.

45

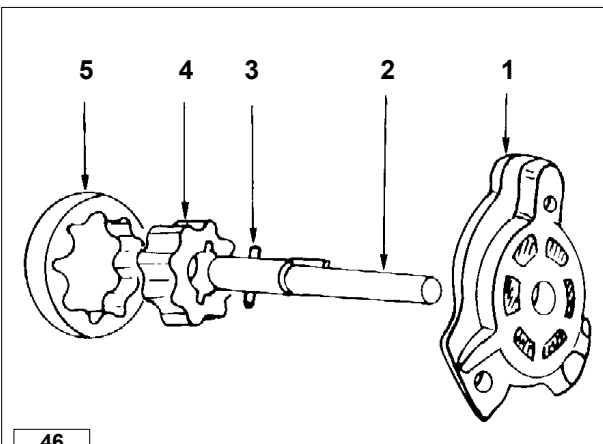

Oil pump

Components:

- 1 Cover
- 2 Oil pump driving shaft
- 3 Key
- 4 Pin
- 5 Internal rotor
- 6 External rotor

46

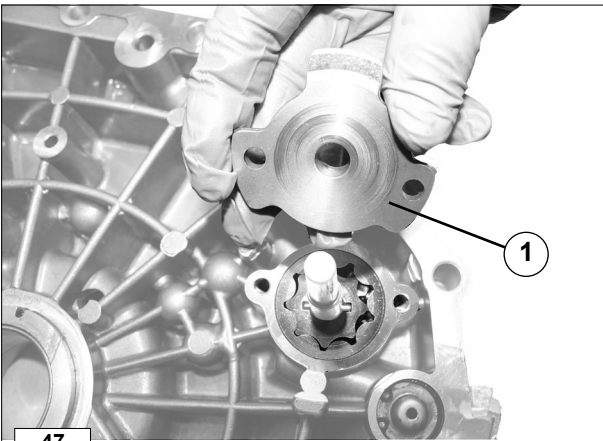

Loosen the fastening screws and remove oil pump cover 1.

47

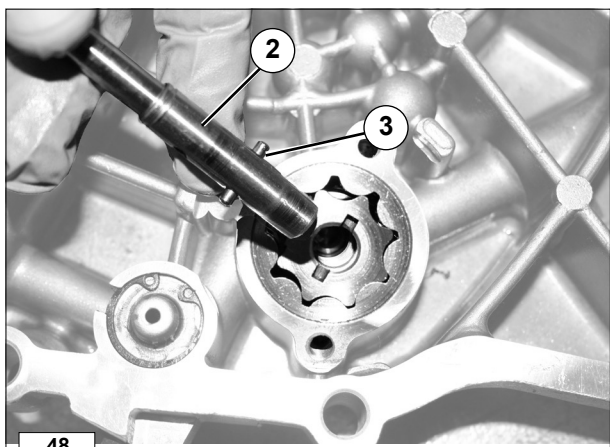

Remove oil pump drive shaft 2 with pin 3.

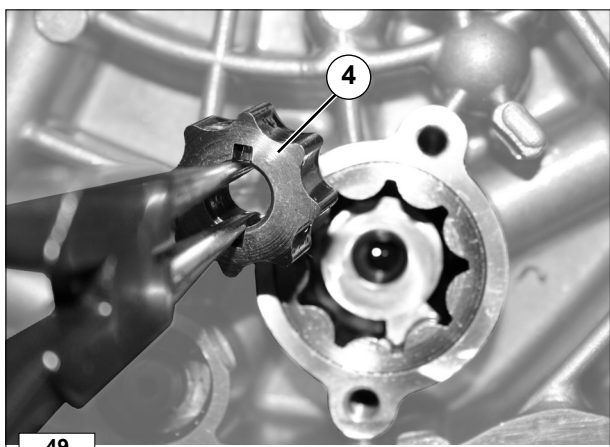

Remove internal rotor 4.

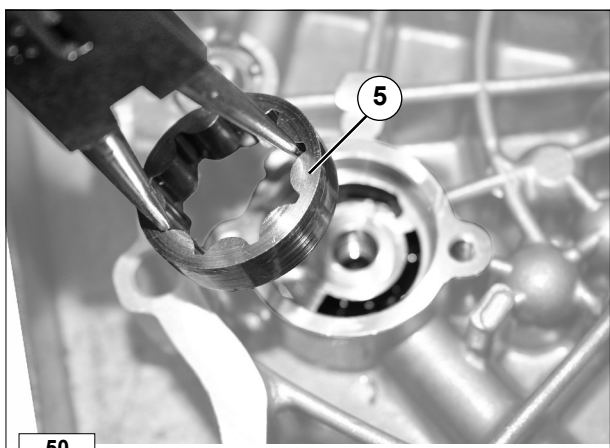

Remove outside rotor 5.

For overhaul and oil pump checks, see page 59.

RECOMMENDATIONS FOR OVERHAULS AND CHECKING

- Information is given in a logical order in terms of timing and sequence of operations. The methods have been selected, tested and approved by the manufacturer's technical experts.
 - This chapter describes procedures for checking, overhauling assemblies and/or individual components.
 - Wash the components with special detergent and do not use steam or hot water.
 - Do not use flammable products (petrol, diesel, etc.) to degrease or wash components. Use special products.
 - Dry all washed surfaces and components thoroughly with a jet of air or special cloths before reassembling them.
 - Apply a layer of lubricant over all surfaces to protect them against oxidation.
 - Check all components for intactness, wear and tear, seizure, cracks and/or faults to be sure that the engine is in good working condition.
 - Some mechanical parts must be replaced *en bloc*, together with their coupled parts (e.g. valve guide/valve etc.) as specified in the spare parts catalogue.
- Important**
To locate specific topics, the reader should refer to the index.
- Before any intervention, the operator should lay out all equipment and tools in such a way as to enable him to carry out operations correctly and safely.
 - The operator must comply with the specific measures described in order to avoid errors that might cause damage to the engine.
 - Before carrying out any operation, clean the assemblies and/or components thoroughly and eliminate any deposits or residual material.

Shaft seals

- Clean the shaft thoroughly and make sure that it is not damaged or scored or become oval-shaped in the areas of contact with the seals.
- Do not use a hammer directly on the gaskets during assembly, to avoid damaging them.
- Lubricate the seal lips, and pointing them in the right direction, place them in their seat using a special pad.
- Be careful not to damage the gaskets while joining them to the shaft.



Danger - Attention

During repair operations, when using compressed air, wear eye protection.

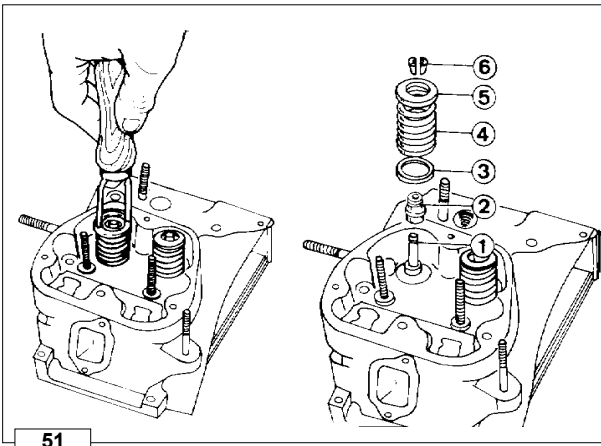

51

Cylinder head

Valves - Disassembly

Components:

- 1 Valve stem
- 2 Oil seal
- 3 Spring washer/set
- 4 Spring
- 5 Cap
- 6 Half collets

Note: To remove half collets place a suitable plate under the valve head and press down firmly as indicated in the figure.

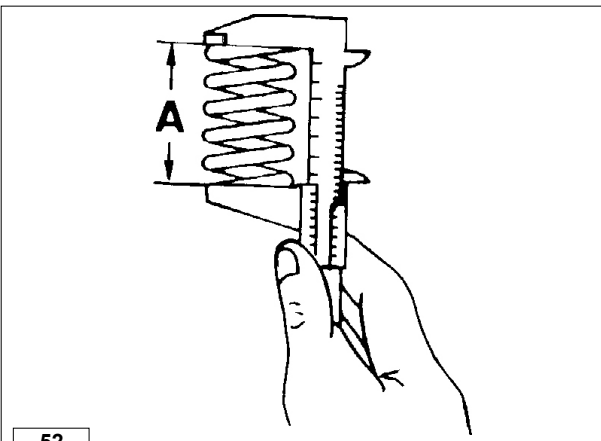

52

Valve, springs

Measure the free length with a caliper.

$A = 34.88$

Note: Replace the spring if the free length **A** is 1 mm less than specified.

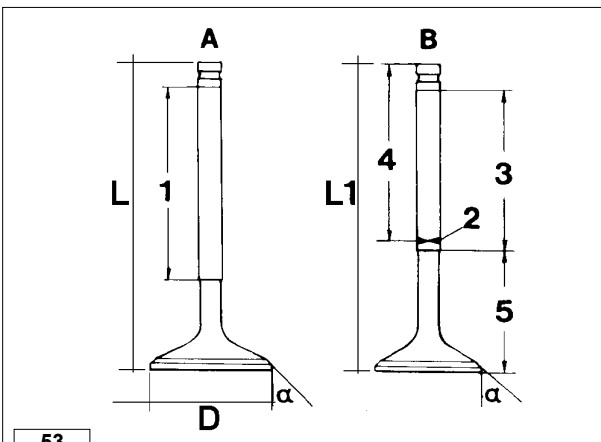

53

Valves, characteristics

Intake valve **A**

Base Material --> X 45 Cr Si 8 UNI 3992	
1	Chrome Plated
D	37.8 - 0 - 0.2
L	For mechanic tappets --> 96.2 - 0.2 + 0.2
α	45° 35' ÷ 45° 65'

Exhaust valve **B** - Stem and head are of two different materials

2	Weld Joint
3	Chrome Plated
4	Base Material --> X 45 Cr Si 8 UNI 3992
5	Base Material --> X 70 Cr Mn Ni N21.6 UNI 3992
L1	For mechanic tappets --> 96.2 - 0.2 + 0.2
α	45° 35' ÷ 45° 65'

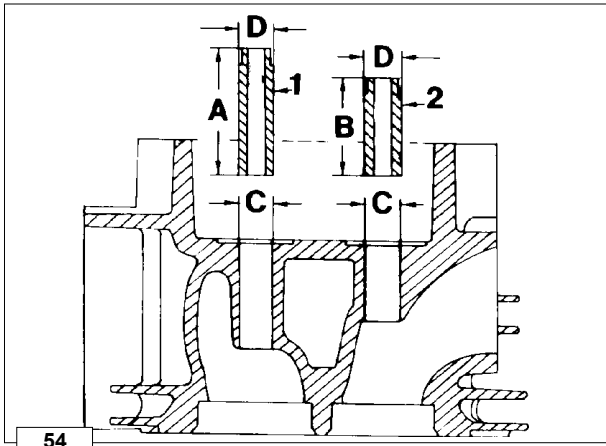

Valves, guides and housings

- 1 Intake guide
- 2 Exhaust guide

Dimensions (mm)

A	40
B	31
C	11.000÷11.018
D	11.040÷11.055

Note: Valve guides with outer diameters increased by 0.5 mm are also available as spares. In this case, housing C must be increased by 0.5 mm for assembly purposes.

54

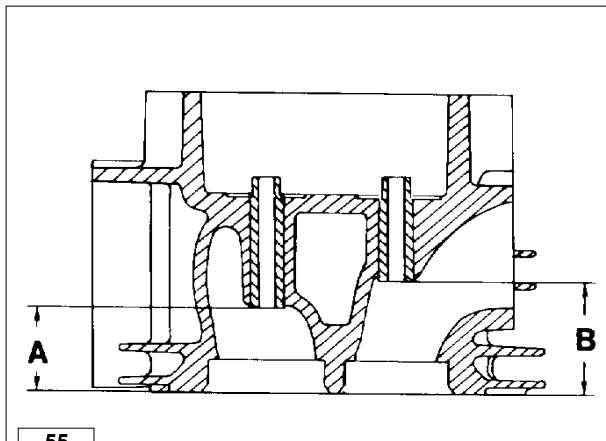

Valves, guide insertion

Insert the guides, considering distance A and B in relation to the block surface.

Dimensions (mm)

A	25.8÷26.2
B	34.8÷35.2

55

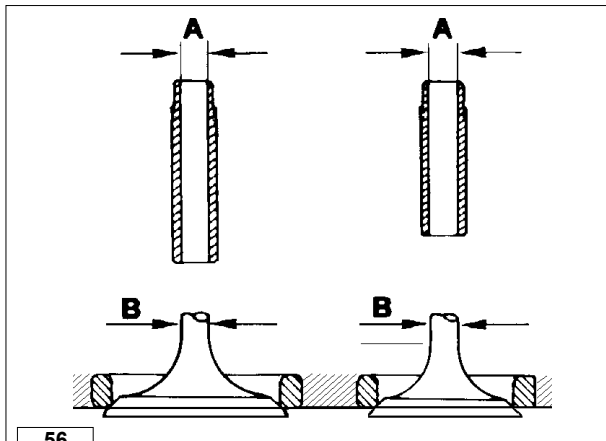

Dimensions and clearance between guides and valve stems (mm)

A	7.025÷7.040
B	6.985÷7.000
(A-B) Clearance	0.025÷0.055
(A-B) Limit	0.14

56

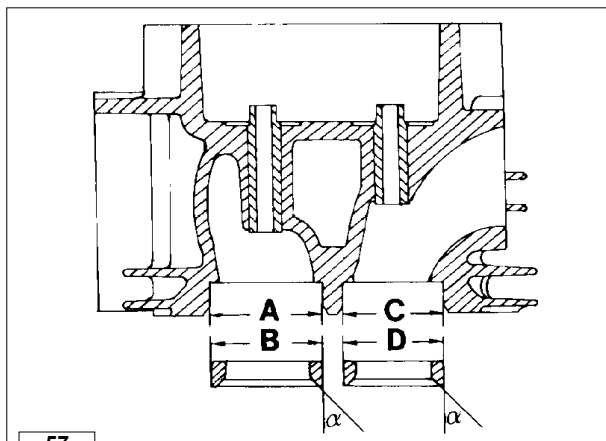

Valves seats and valve seat bores

Dimensions (mm)

A	39.00÷39.01
B	39.10÷39.12
C	35.00÷35.01
D	35.10÷35.12

Note : Since the seats are supplied pre-finished, they must not be machined after having been inserted.

57

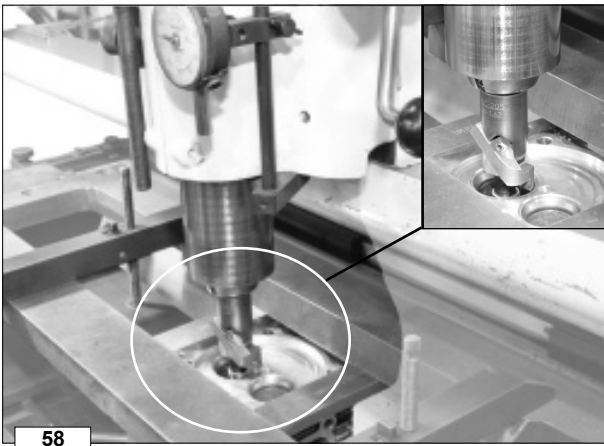

58

Valve seats - Removal

! Important

Place and clamp the cylinder head firmly onto the milling machine.

Remove the valves, taking care the milling machine is aligned to the valve seats (see detail in the figure).

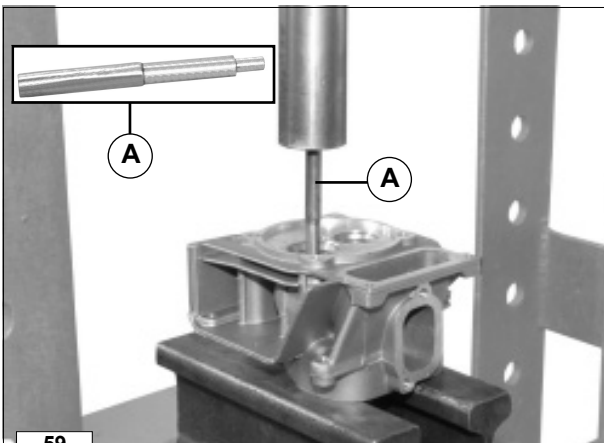

59

Valve guides - Removal

! Important

Firmly place the cylinder head under a press.

Place tool A, p/n 1460-337, in the valve guide. Operate the press and remove the valve guides.

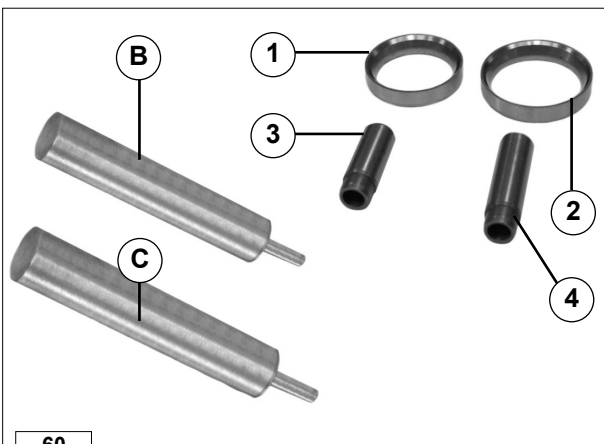

60

Legend

- 1 Exhaust valve seat
- 2 Intake valve seat
- 3 Exhaust valve guide
- 4 Intake valve guide

B Valve guide/valve seat pressing tool- intake valve, p/n 1460-338
 C Valve guide/valve seat pressing tool-exhaust valve, p/n 1460-339

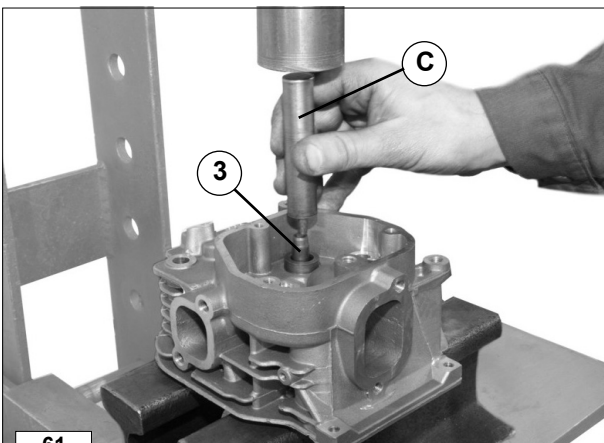

61

Valve guides - Reassembly

! Caution – Warning

Thoroughly wash the cylinder head and the valve guides before reassembly.

! Important

Firmly place the cylinder head under a press.

Fit the valve guide into its seat. Place tool C onto the valve guide. Operate the press to drive the valve guide until tool C touches the cylinder head surface. Repeat the same operations to assemble the other valve guide, using the tool B.

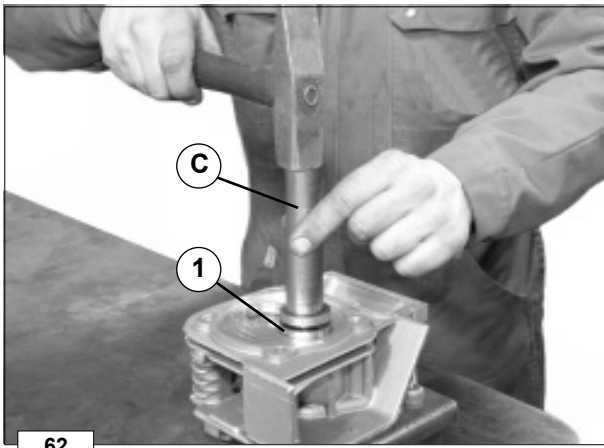

Valve seats - Reassembly

Caution – Warning

Thoroughly wash the cylinder head and the valve seats before reassembly.

Place valve seat **1** onto its seat.
Place the driving tool for valve seat **C** on the valve seat.
Drive the seat in by hammering on tool **C** until the seat is inserted in its housing to its limit stop.
Repeat these operations for valve seat **2** using the tool **B**.

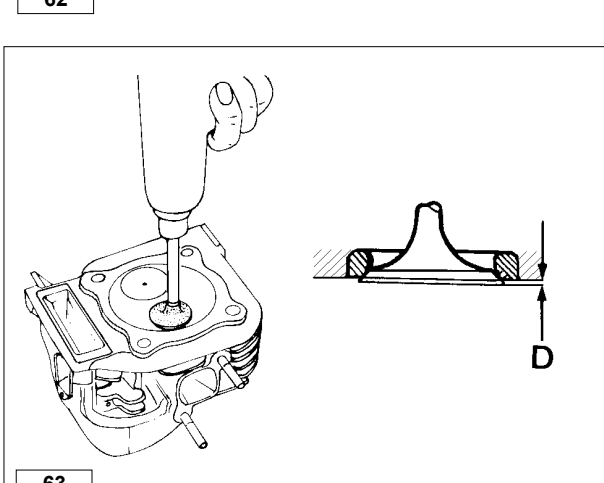

Valve seat lapping

After cutting valve seats, lap valve seats with fine lapping compound.

D	0.35÷0.65
wear limit	1.5

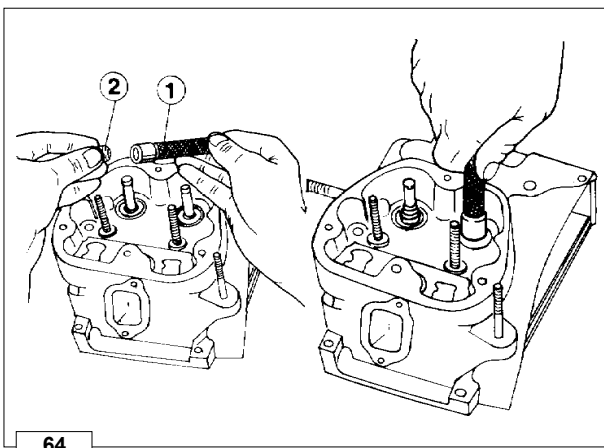

Valves - Oil seal in valve guide

To prevent seal **2** from being deformed when the valve guide is mounted, fit it into tool **1** p/n° 1460-047 after having thoroughly lubricated it.

Firmly press to insert the oil seal in the seat on the valve guide to its limit stop.

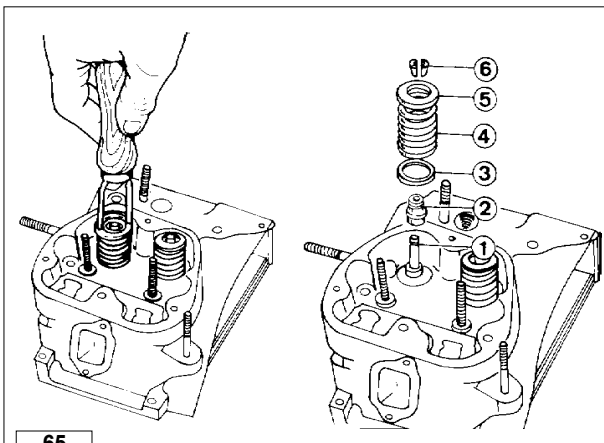

Valves - Reassembly

Components:

- 1 Valve stem
- 2 Oil seal
- 3 Spring washer/set
- 4 Spring
- 5 Cap
- 6 Half collets

Caution – Warning

To reassembly half collets place a suitable plate under the valve head and press down firmly as indicated in the figure.
Check that the half collets are correctly attached to the valve.

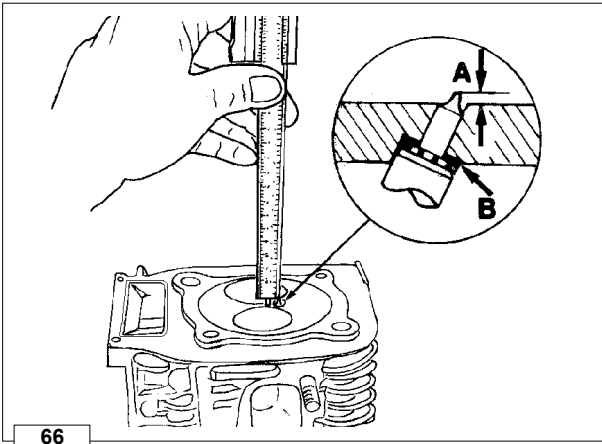

66

Injector protrusion

The end of nozzle **A** should protrude from the cylinder head plane :

mm 3.00 ÷ 3.50

- Adjust with copper gaskets **B** with thickness of 0.5, 1 and 1.5 mm

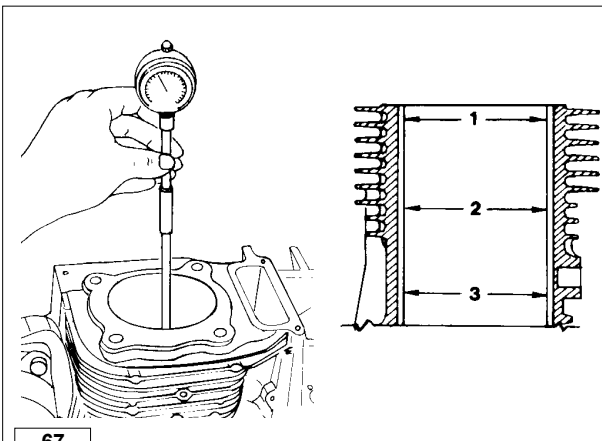

67

Cylinder

Set a bore gauge to zero with a calibrated ring.
Check diameter at **1**, **2** and **3**; repeat the operation at the same points after turning the bore gauge 90°.
If wear exceeds the max. given value by 0.05, bore the cylinder and fit oversize piston and rings.
See table "Piston and cylinder dimensions" for cylinder diameter values.

Important

Protect the contact surfaces with lubricating oil, to prevent them from rusting.

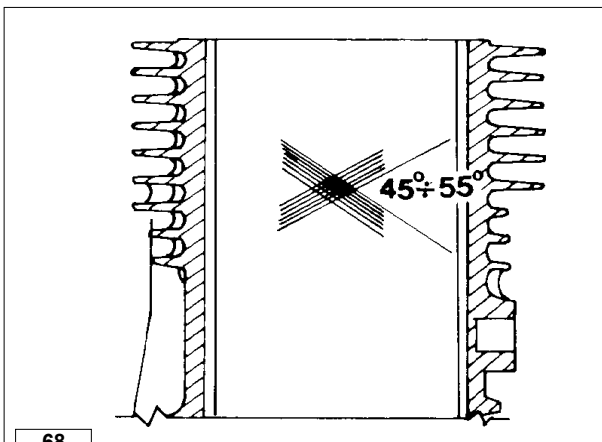

68

Caution - Warning

Do not manually hone the cylinder bore surfaces with emery cloth or other means.

Cylinder roughness

The cross-hatch pattern should be at an angle of 45°-55°; lines should be uniform and clear in both directions.
Average roughness must range between 0.35 ÷ 0.60 µm.
The cylinder surface which comes into contact with piston rings should be machined with the plateau method.

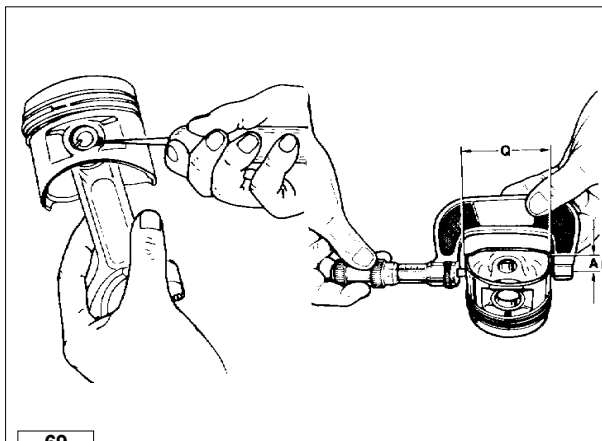

69

Piston

Remove circlips and piston pin.
Measure diameter **Q** at the **A** distance from the skirt bottom (**A**=12 mm).
Replace the piston and piston rings if wear on the diameter is 0.05 mm more than the minimum value given (see table).

Note: Oversize pistons of 0.50 and 1.00 mm are available.

Piston and cylinder dimensions (mm)		
Ø Cilinder	Ø Piston	Wear limit
86.000÷86.015	85.905÷85.920	0.08÷0.11

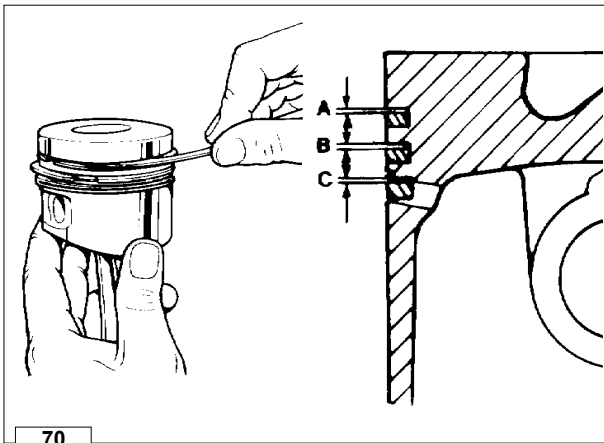

Piston rings, play between the slots (mm)

A	0.11÷0.15
B	0.07÷0.11
C	0.03÷0.065

Replace the piston or piston rings if the value exceeds the maximum limit.

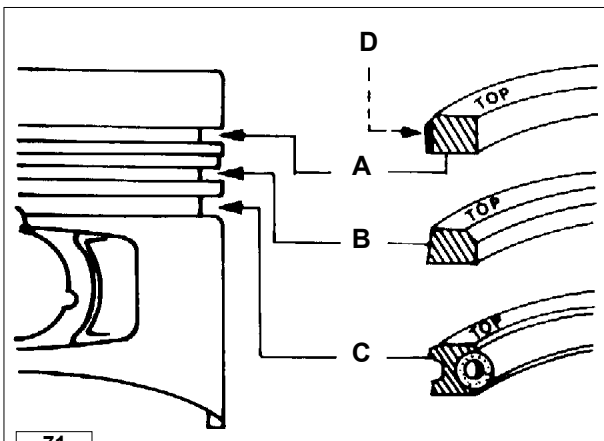

Piston rings, assembly order

- A = 1st Nitrided plated piston ring
- B = 2nd piston ring (torsional)
- C = 3rd Nitrided plated piston ring (oil scraper)
- D = Chromium plated zone

Note: If a word (top, or some other word) is written on the surface of a piston ring, mount that surface upwards.
Before inserting the piston into the cylinder, oil and turn the piston rings so that the cuts are staggered 120° to each other.



Piston rings, distance between the tips (mm)

Fit the piston ring into the top part of the cylinder and measure the distance between the tips.

Piston rings	Value	Wear limit	Stamped ko
1st piston ring	0.20÷0.35	1.00	chromium plated
2nd piston ring	0.30÷0.50	1.00	nitrided
3rd piston ring, oil scraper	0.20÷0.50	1.00	chromium plated

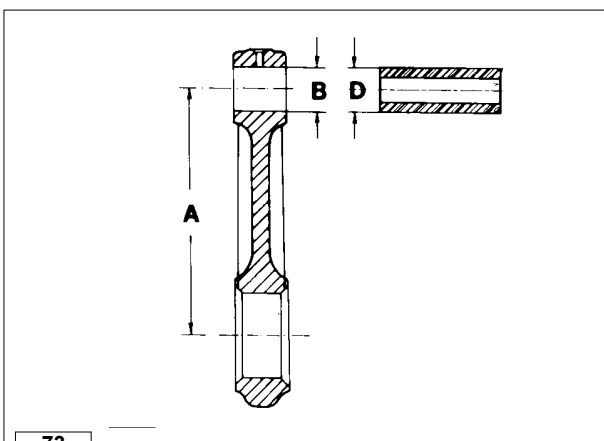

Connecting rod, piston pin

A	122.07÷122.13
B	23.04÷23.05
D	22.995÷23.000
(B-D)	clearance 0.04÷0.055
(B-D)	wear limit 0.08

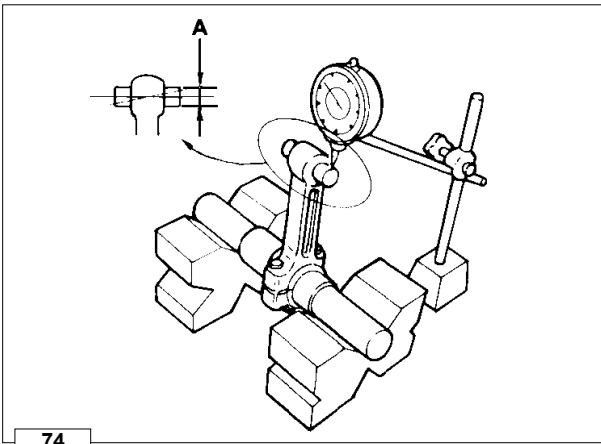

74

Connecting rod alignment

Use a dial gauge as shown in the figure.
Check that axes are aligned using the piston pin; axial mis alignment **A** = 0.015; limit 0.03 mm.
If the difference is greater, the connecting rod is not aligned, and it must be replaced with a new one.

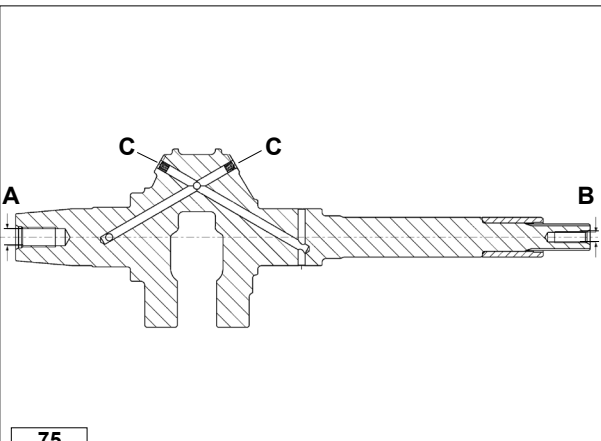

75

Crankshaft, lubrication ducts, bore thread on flywheel side and p.t.o.

Remove plugs **C** and check that the lubrication duct is perfectly clean.
Close with a new plug checking for proper sealing.
A = M14x1.5 (turn counterclockwise)
B = M8x1.25

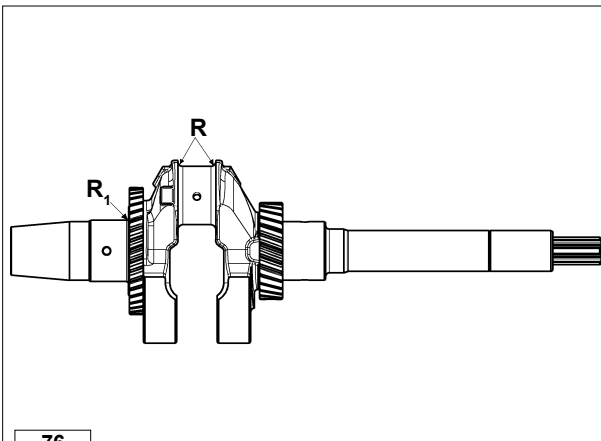

76

Crankshaft, connection radius

 **Caution – Warning**

When the crankpin and main journal are ground, values **R** and **R₁** must be obtained again to prevent the drive shaft from breaking.

Radius **R** that joins the crankpin to the supports is 3.3÷3.7 mm.
Radius **R₁** that joins the main journal to the timing gear is 1.5 mm.

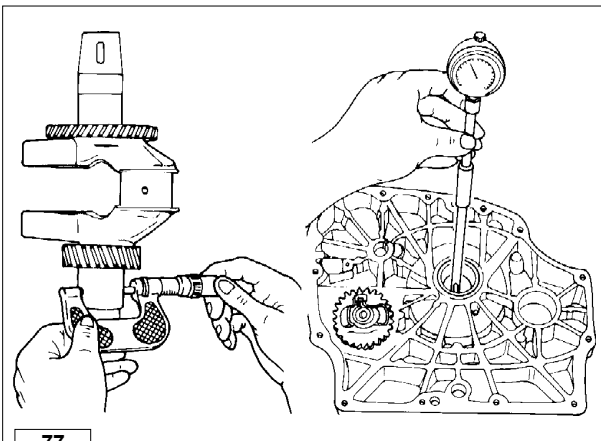

77

Crankshaft, journal/crankpin diameter check, timing cover bearing internal diameters and crankshaft and big end bearing support

Use an outside micrometer for the journal and an inside dial gauge for the timing cover, crankshaft and big end bearings.

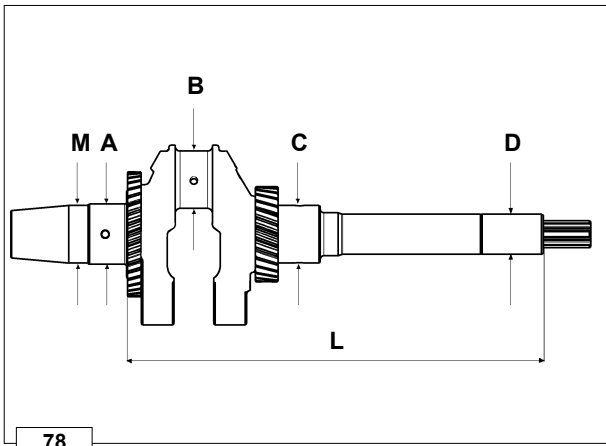

Crankshaft - journal diameter (mm)

The undersizes for the crankpin and main journal are 0.25, 0.50 and 1 mm.

M oil seal working area	39.959+39.975
A	41.984+42.000
B	39.984+40.000
C	39.984+40.000
D oil seal working area	27.990+27.977
L	291.500+291.700

78

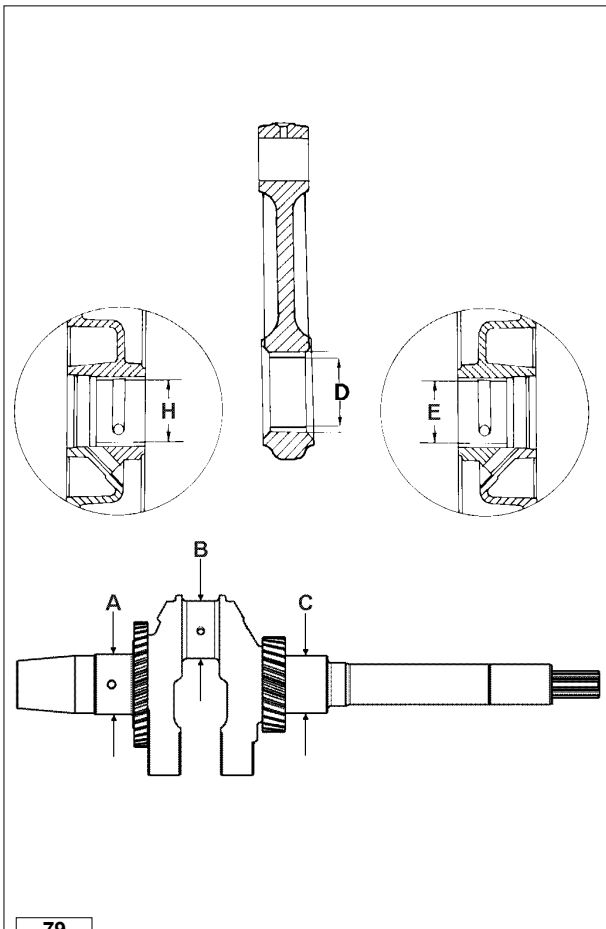

Crankshaft - Main bearing, big end, and crankshaft bearing internal diameters, and relevant clearances.



Caution – Warning

The gears must be mounted with the right tools so that they can be correctly timed.

The gears should not therefore be demounted.

Only the complete shaft is available as a spare.

Dimensions (mm)

D	40.030+40.046
E	40.030+40.050
H	42.020+42.062

Clearance (mm)

(D-B)	0.030+0.062
(D-B) Limit	0.120
(E-C)	0.030+0.066
(A-H)	0.020+0.078

79

Availability of bearings

Main bearings are available at their nominal value or undersized 0.25, 0.50 and 1.0 mm.

Connecting rods bearing are available at nominal value or undersized 0.25 and 0.50 mm.



80

Timing cover bearing, crankshaft bearing, and thrust washer replacement

Legend

- 1 Thrust washer on timing cover side
- 2 Thrust washer on crankcase side
- 3 Bearing on timing cover side
- 4 Bearing on crankcase side.

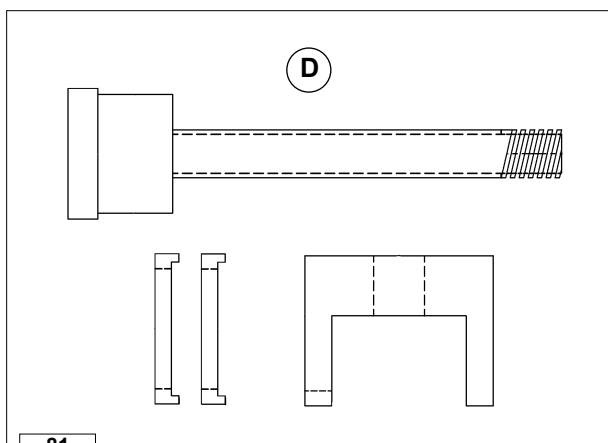

81

D Assembly/extraction tool for timing cover side bearing and for crankcase side bearing p/n 1460-333

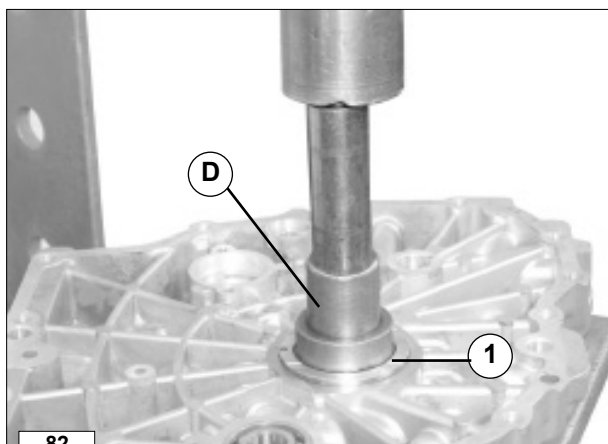

82

Timing cover bearing - Extraction

Important

Firmly place the timing cover on a press.

Place bearing extraction tool **D** on the bearing. Operate the press, remove the bearing and then thrust washer **1**.

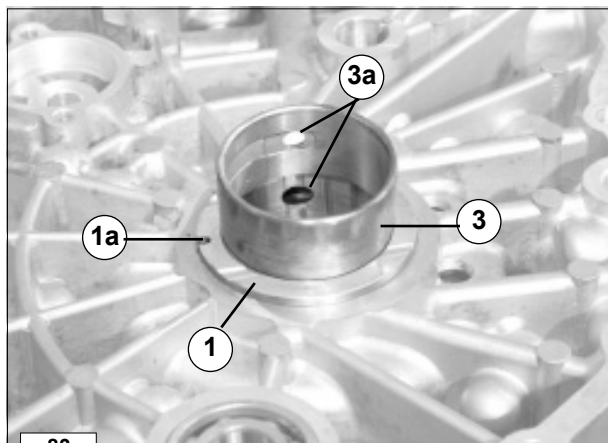

83

Timing cover bearing - Reassembly

Caution – Warning

Thoroughly wash the timing cover, thrust washer **1** and bearing **3**.

Important

Firmly place the timing cover on a press.

Assemble timing cover **1** referring to pin **1a** on the timing cover. Place bearing **3** for the assembly taking care holes **3a** are aligned.

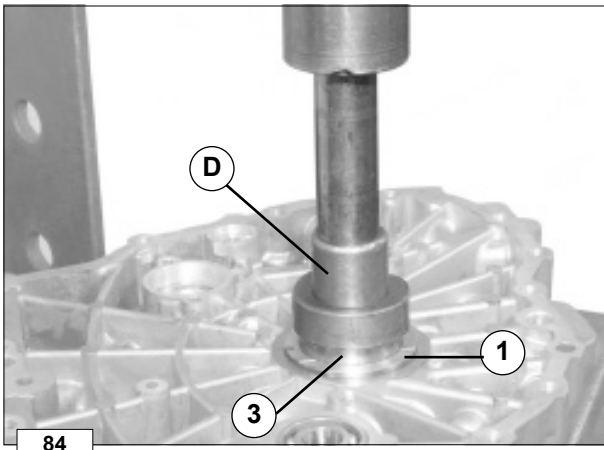

Place bearing driving tool **D** on bearing **3**.
Operate the press and drive bearing **3** in until tool **D** touches thrust washer **1**.

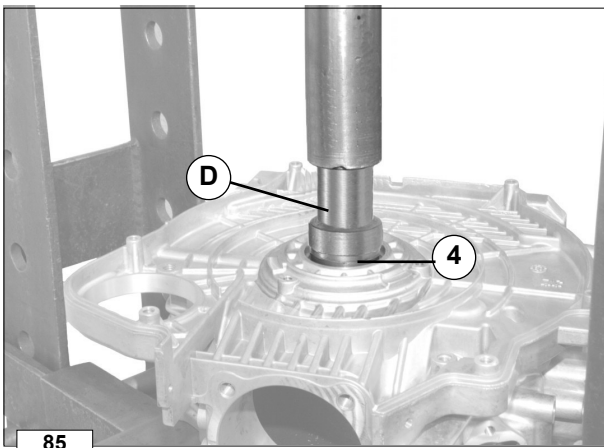

Crankcase bearing - Extraction



Important

Place the crankcase firmly on a press, flywheel side facing upwards.

Remove the oil seal ring flywheel side.
Place bearing extraction tool **D** on bearing **4**.
Operate the press, remove bearing **4** and then thrust washer **2**, placed inside the crankcase.

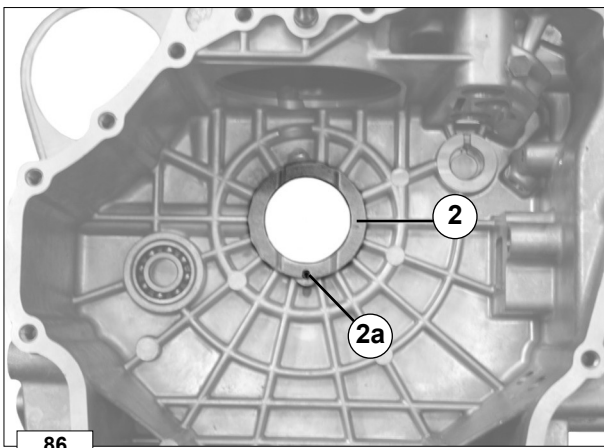

Crankcase bearing - Reassembly



Caution - Warning

Thoroughly wash the crankcase, thrust washer **2** and bearing **4**.



Important

Place the crankcase firmly on a press, flywheel side facing downwards.

Assemble thrust washer **2** referring to pin **2a** on the crankcase.

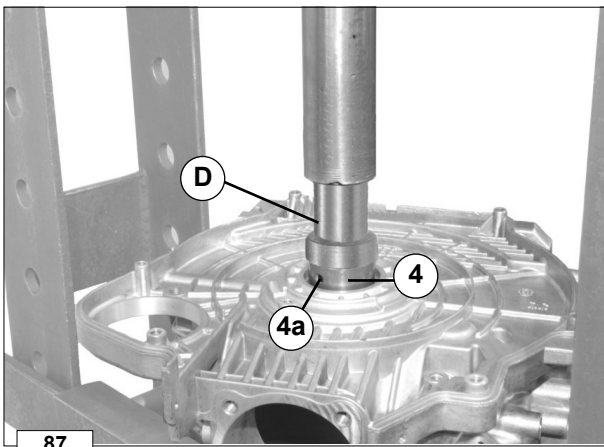

Important

Turn the crankcase with the flywheel side facing upwards, and place it firmly on a press.

Place bearing **4** for the assembly taking care holes **4a** are aligned (see figure).
Operate the press and drive bearing **4** in until tool **D** reaches its stop.

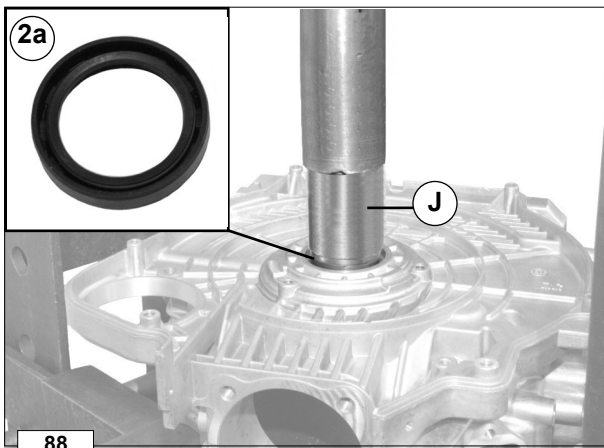

Oil seal ring on crankcase - Reassembly

After lubricating the oil seal ring **2a** (see detail), place it on the bearing making sure its internal channel (see figure on the side) is facing downwards.
Operate the press and drive the oil seal ring in until tool **J** reaches its stop.

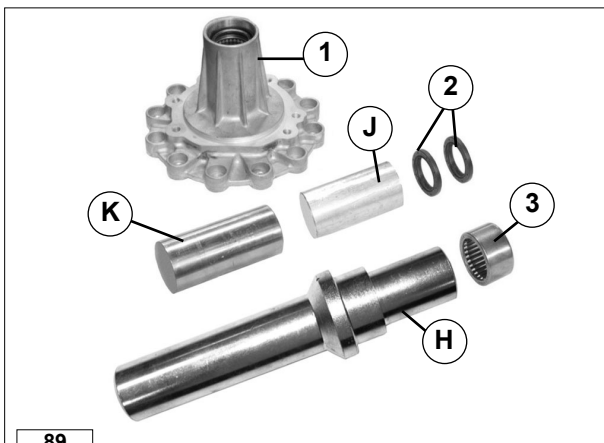

Gearbox extension, bearing and oil seal replacement

Legend

- 1 Gearbox extension
- 2 Gearbox extension oil seal rings
- 3 Roller bearing

- J Oil seal pressing tool flywheel side p/n 1460-328
- K Oil seal pressing tool PTO side (gearbox extension) p/n 1460-346
- H Roller bearing assembly/disassembly and PTO side oil seal pressing tool (gearbox extension) p/n 1460-347.

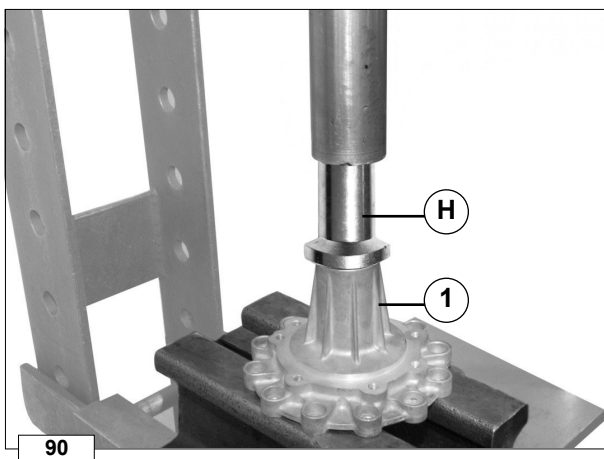

Roller bearing - Disassembly

Important

Firmly place gearbox extension 1 on the press.

Place bearing assembly tool **H** on the bearing.
Operate the press to remove the roller bearing and the oil seal ring.

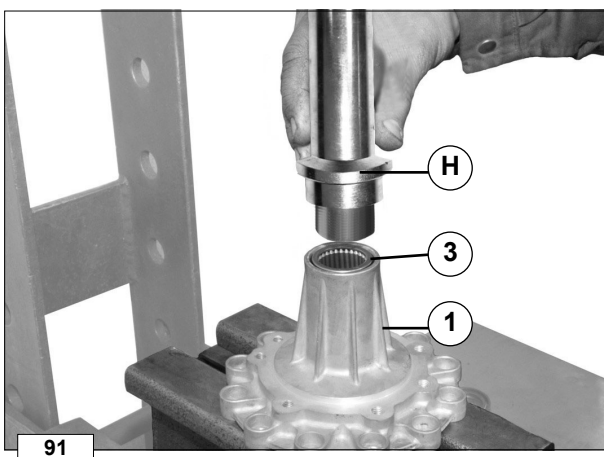

Roller bearing - Reassembly

Caution – Warning

Thoroughly wash the gearbox extension and the roller bearing.

Important

Firmly place gearbox extension 1 on the press.

Place roller bearing **3** on the gearbox extension opening.
Place bearing assembly tool **H** on roller bearing **3**.
Operate the press to assemble the roller bearing.

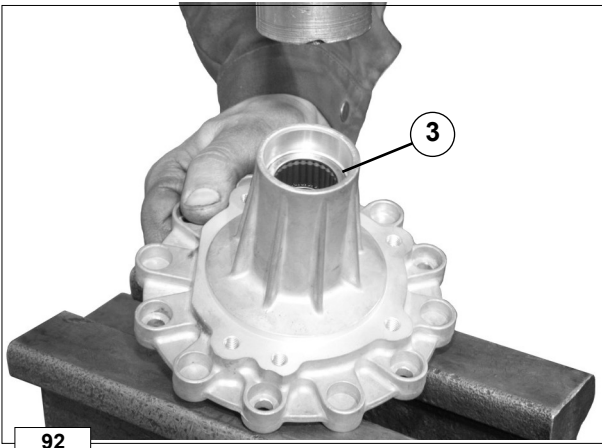

Once assembled, roller bearing 3 should be at the same level of the reference ridge on the gearbox extension.

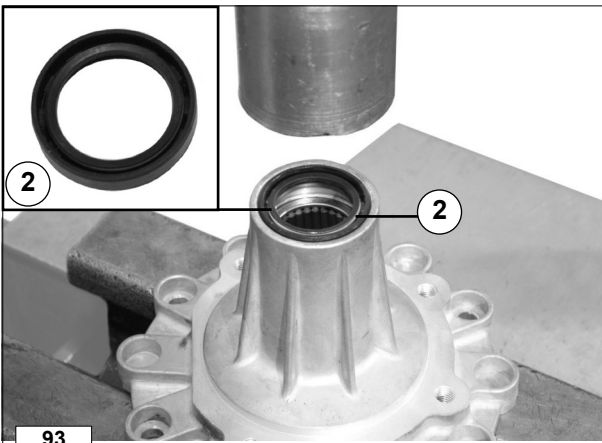

Oil seal ring - Reassembly

Caution – Warning

Lubricate the oil seal ring before reassembly.

Place oil seal ring 2 on the gearbox extension opening making sure the channel is facing upwards (see figure on the side).

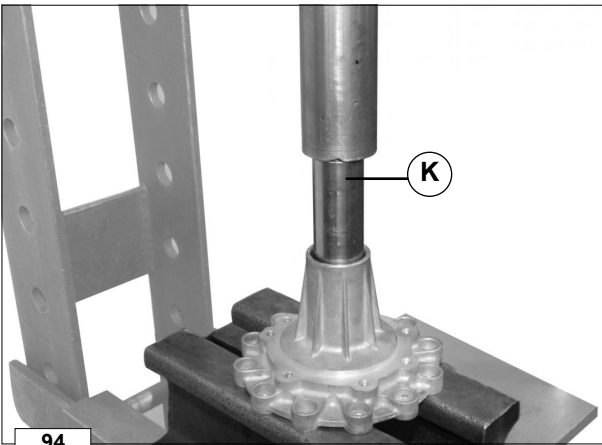

Place oil seal ring assembly tool K on oil seal ring 2.

Operate the press to assemble the oil seal ring.

Repeat these operations for the second oil seal ring, using the tool H. Make sure the second oil seal ring is placed on the first one with its channel facing downwards.

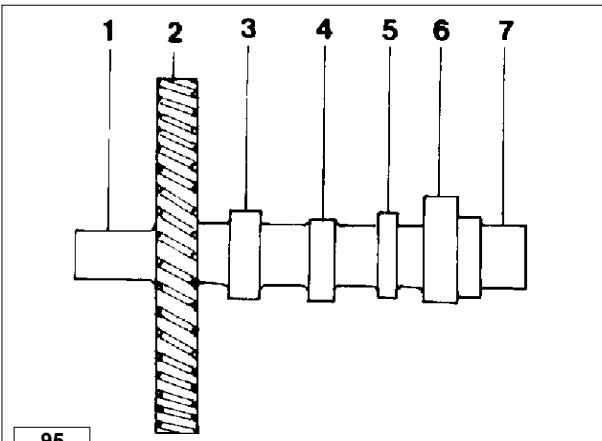

Camshaft

Components:

- 1 Journal, gear cover on timing side
- 2 Gear
- 3 Exhaust lobe
- 4 Injection lobe
- 5 Fuel pump eccentric
- 6 Intake lobe
- 7 Journal, crankcase side

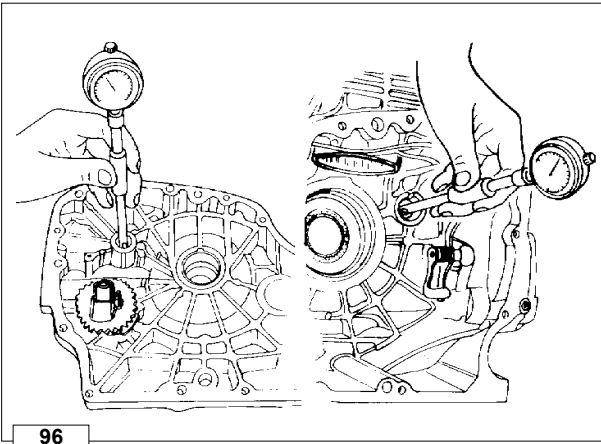

96

Camshaft journals and bore

Use an inside dial gauge to measure the camshaft pin housing diameters.

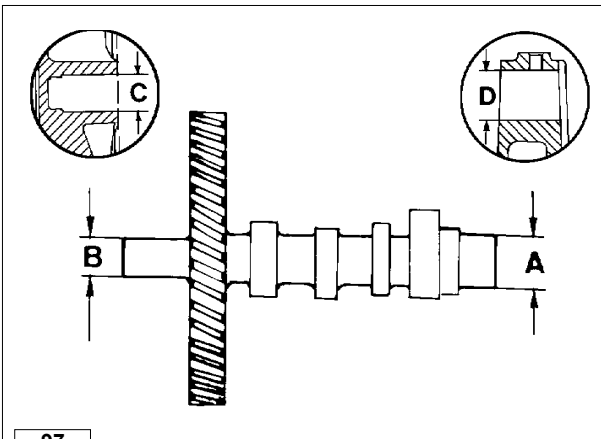

97

Camshaft, pin and housing dimensions, and relevant clearances (mm)

A	17.966÷17.984
B	15.957÷15.984
C	16.000÷16.018
D	18.00÷18.018
(D-A)	0.016÷0.052
(D-A) Limit	0.100
(C-B)	0.016÷0.061
(C-B) Limit	0.120

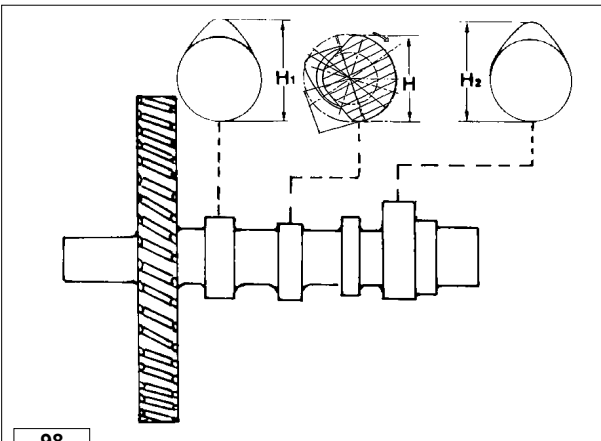

98

Camshaft, cam height (mm)

H	39.75÷39.80
H₁	36.15÷36.20
H₂	35.85÷35.90

Note: Replace camshaft if cam wear exceeds the minimum given value of **H**, **H₁** and **H₂** by 0.1 mm.

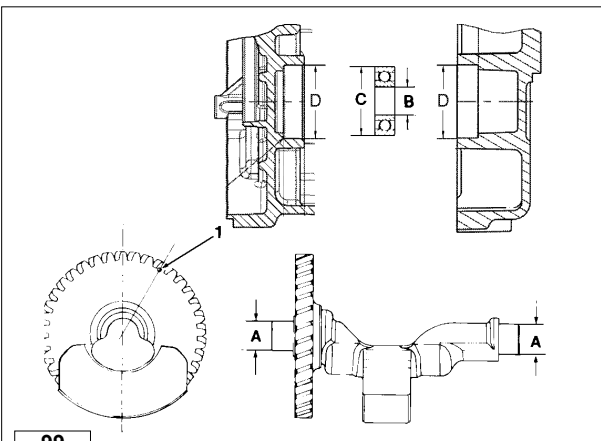

99

Dynamic balancer (on request)

The dynamic balancer is supported by two identical ball bearings housed in the crankcase and in the gear cover on the timing side respectively.

1 is the reference point for timing with the cranksaft gear (see below). Dimensions (mm):

A	14.969÷14.980	
B	14.990÷15.000	
C	34.989÷35.000	
D	34.958÷34.983	(bearing housing diameter on crankcase and gear cover on timing side).

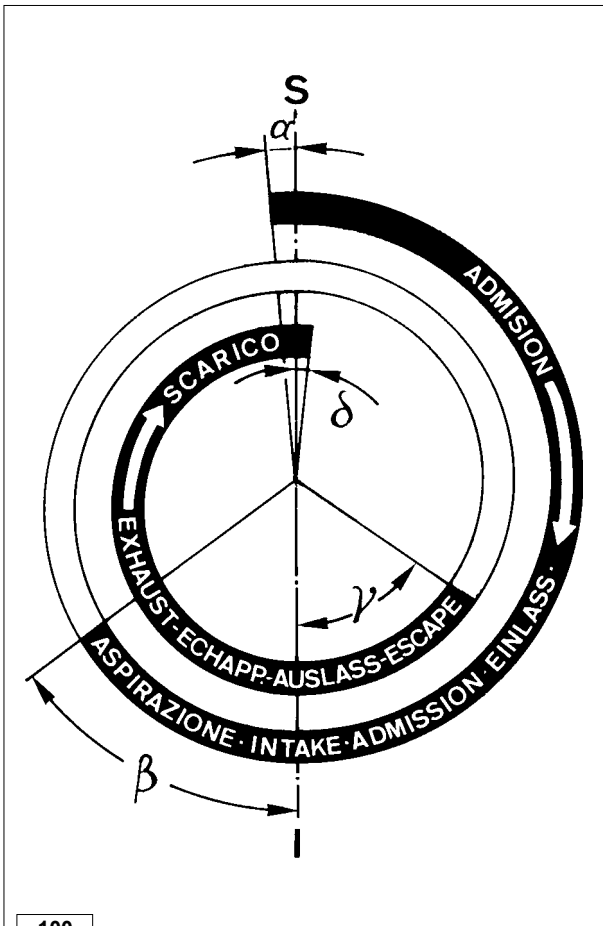

100

Valve timing - Angles

Angle values are measured by turning the crankshaft clockwise.

S = Piston at top dead centre
I = Piston at bottom dead centre

α = Intake valve opening
β = Intake valve closing
γ = Exhaust valve opening
δ = Exhaust valve closing

Operating valve timing angles with prescribed valve clearance

α = 21° before **S**
β = 58° after **I**
γ = 80° before **I**
δ = 33° after **S**

Timing valve angles for checking

To check the timing valve angles set the valve clearance to 0 (zero); measure the angles achieved when the valve lift is 2 mm.

α = 20° after **S** corresponding to 45 mm
β = 17° after **I** corresponding to 38.5 mm
γ = 26° before **I** corresponding to 59 mm
δ = 20° before **S** corresponding to 45 mm

Note: Values measured on the circumference of the flywheel **D** = 260 (one degree corresponds to 2.26 mm).



Caution – Warning

After checking set the valve clearance back to the prescribed one.

RECOMMENDATIONS FOR REASSEMBLING

- Information is given in a logical order in terms of timing and sequence of operations.
The methods have been selected, tested and approved by the manufacturer's technical experts.
 - This chapter describes procedures for installing assemblies and/or individual components that have been checked, overhauled or replaced with original spare parts.
- Important**
- To locate specific topics, the reader should refer to the index.
- The operator must wash, clean and dry components and assemblies before installing them.
 - The operator must make sure that the contact surfaces are intact, lubricate the coupling parts and protect those that are prone to oxidation.
 - Before any intervention, the operator should lay out all equipment and tools in such a way as to enable him to carry out operations correctly and safely.
 - For safety and convenience, you are advised to place the engine on a special rotating stand for engine overhauls.
 - Before proceeding with operations, make sure that appropriate safety conditions are in place, in order to safeguard the operator and any persons involved.
 - In order to fix assemblies and/or components securely, the operator must tighten the fastening parts in a criss-cross or alternating pattern.
 - Assemblies and/or components with a specific tightening torque must initially be fastened at a level lower than the assigned value, and then subsequently tightened to the final torque.

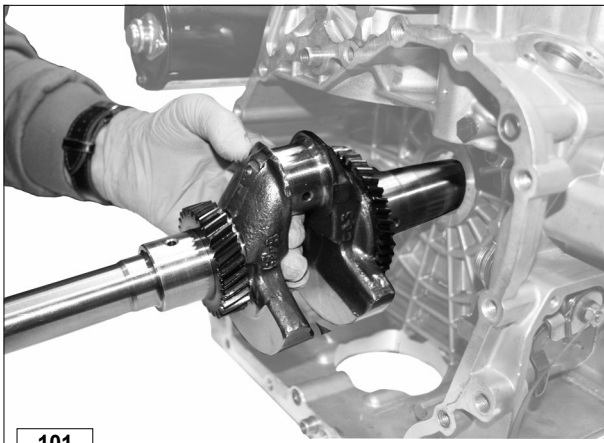

101

Crankshaft

After lubricating the crankshaft and the main bearing, insert the crankshaft into the crankcase support, as shown in the figure.

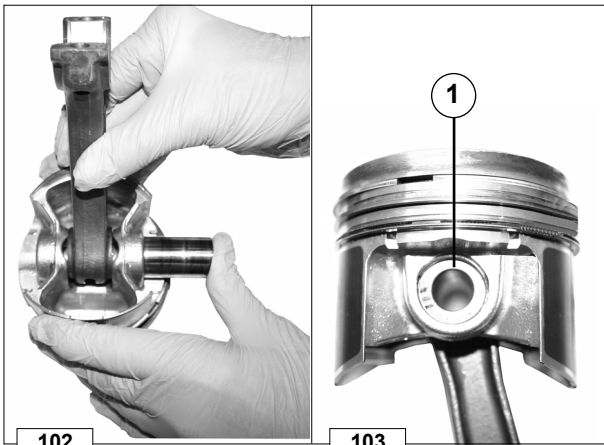

102

103

Piston



Caution – Warning

Lubricate the following parts with oil before mounting: the piston pin, the piston, the cylinder and the big-end bearing

Connect piston to connecting rod, lubricate piston pin and introduce it into the piston / connecting rod assembly by exerting pressure with your thumb (fig. 104).

Fit both piston pin circlips **1** and check that they are well seated.



Rings



Important

**Generously lubricate the rings.
Offset the ring tips by 120°.**

Use compression pliers to insert the piston into the cylinder.

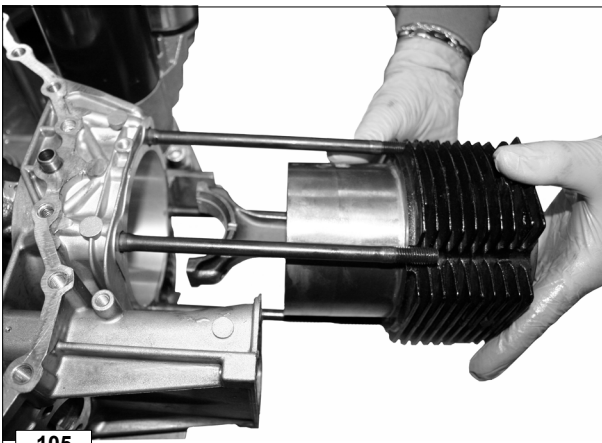

Cylinder

After lubricating the connecting rod big end bearing, insert the cylinder, piston and connecting rod assembly from its seat into the crankcase, taking care the cylinder keeps its correct position, as shown in figure 106.

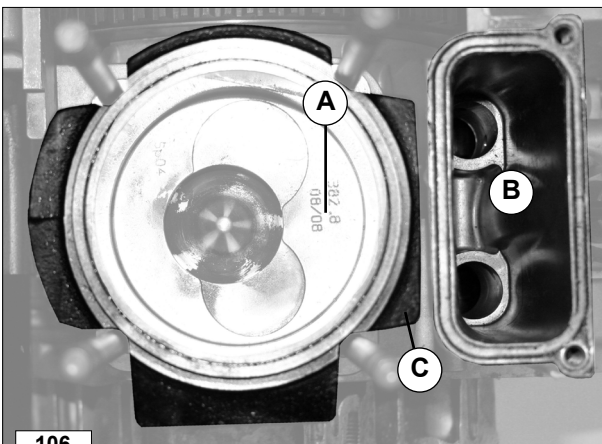

Note: When introducing both the connecting rod and the piston into the cylinder make sure that the larger crown surface **A** (if compared to the combustion chamber) is on the same side as the pushrod opening **B**.

Insert the cylinder in the crankcase with the shorter and flatter side of cooling fins **C** facing the push-rod opening **B**.

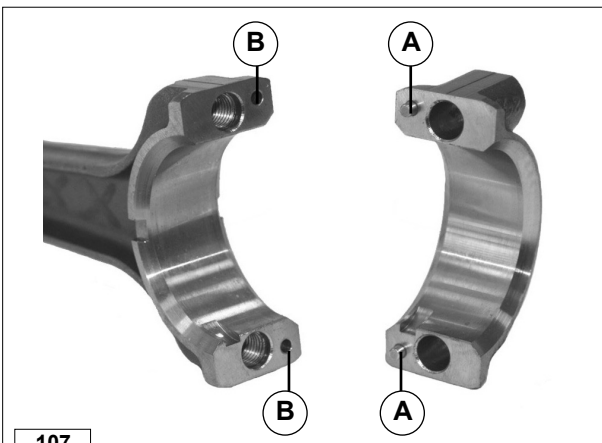

Connecting rod big end cap



Caution - Warning

While reassembling the big end, we suggest cleaning all parts thoroughly, as well as lubricating generously in order to avoid risks of seizure at the first start

When reassembling, make sure pins **A** on the connecting rod big end cap are in line with holes **B** on the connecting rod shaft.

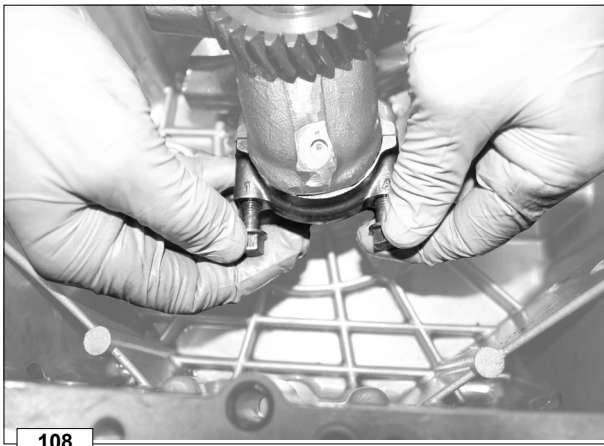

108

Connecting rod, tightening

Insert the connecting rod cap screws without tightening too firmly.

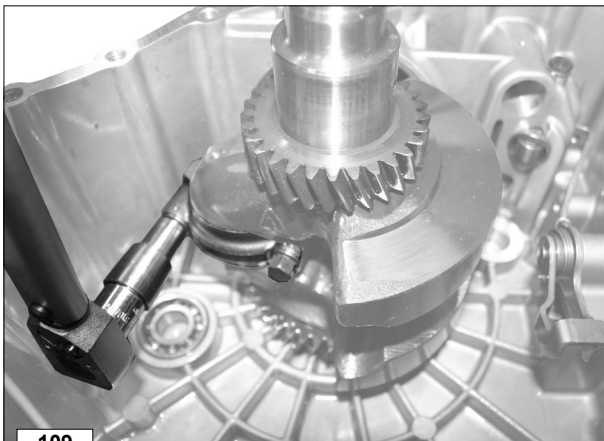

109

Tighten the connecting rod cap screws alternately by using a torque wrench until they have been tightened to the specified torque of 35 Nm.

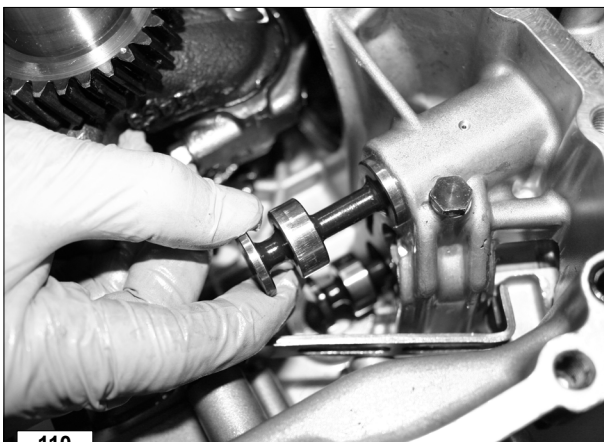

110

Valve tappets

Insert the tappets after lubricating them in their seat in the crankcase.

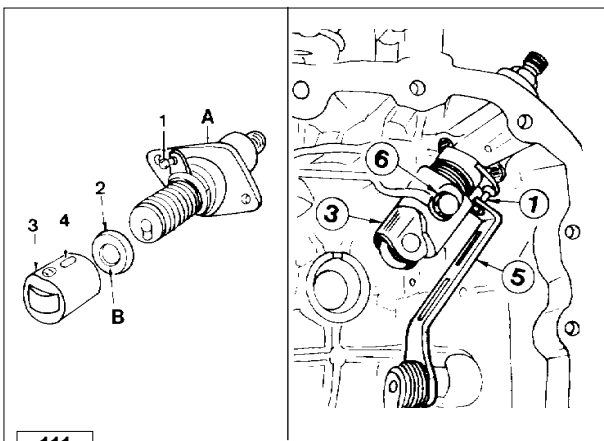

111

Injection pump and tappet fitting in the crankcase

Fit tappets **3** so that screw **6** is introduced into guide **4**. Tighten screw **6** to 9 Nm and check that the tappet is free to move downwards.
 Fit pad **2** into the tappet so that recess **B** points downwards as shown in the figure. (For pad spacer, see fig. 162)
 Fit the injection pump into the crankcase complete with gasket positioning flow control **1** in the fork of lever **5** which should be in the maximum flow position.

Caution – Warning

When removing the injection pump from its housing make sure that spacer **2 is not dropped into the oil sump; injection pump operation will be impaired if the spacer is not installed.**

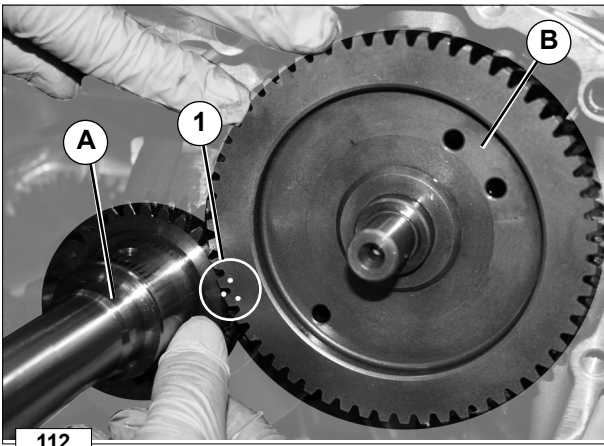

Camshaft



Lubricate the camshaft bearing on the crankcase.

Match the reference tip on crankshaft gear **A** with the 2 ones on camshaft gear **B** (see circled area 1).
Insert the camshaft.

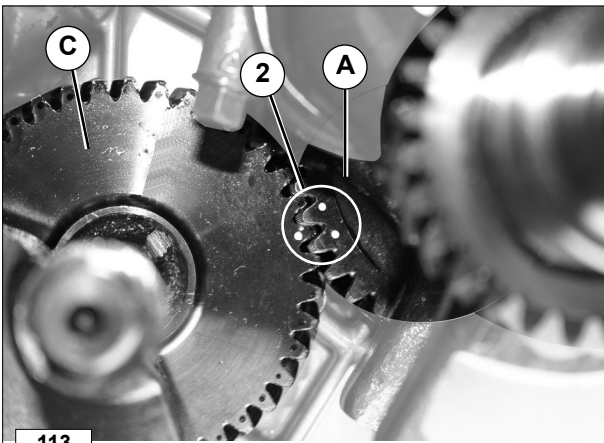

Equalizer shaft



Lubricate the equalizer shaft support bearing.

Match the 2 reference points on crankshaft gear **A** with the one on equalizer shaft **C** (see circled area 2).
Insert the equalizer shaft.

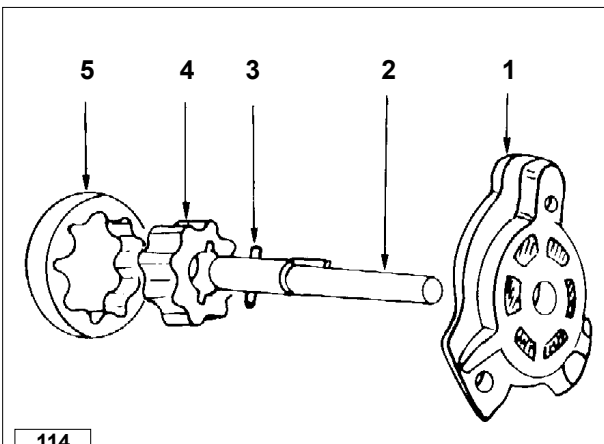

Oil pump

Components:

- 1 Cover
- 2 Oil pump driving shaft
- 3 Key
- 4 Pin
- 5 Internal rotor
- 6 External rotor

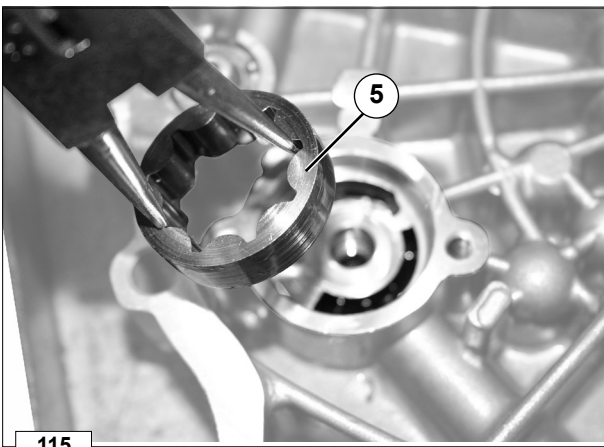

Insert outside rotor **5**.

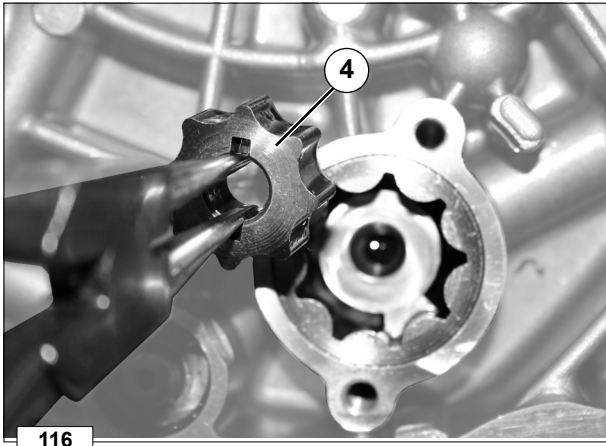

Insert internal rotor **4** with pin seat **3** facing the assembler.

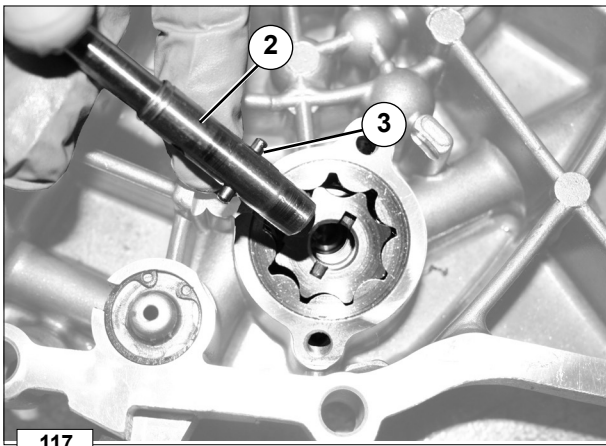

Insert oil pump drive shaft **2** together with pin **3**, which should be inserted in its seat on internal rotor **4**.

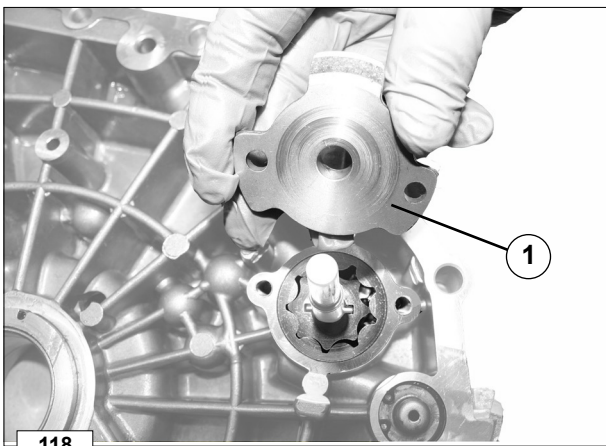

Assemble oil pump cover **1** and tighten the screws alternately to 10 Nm.

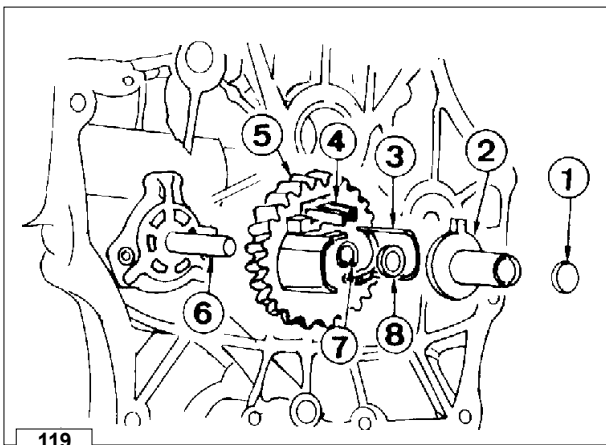

Speed governor gear

Components:

- 1 Spool spacer
- 2 Spool
- 3 Weights
- 4 Spool guide
- 5 Gear
- 6 Oil pump driving shaft
- 7 Circlip
- 8 Thrust ring

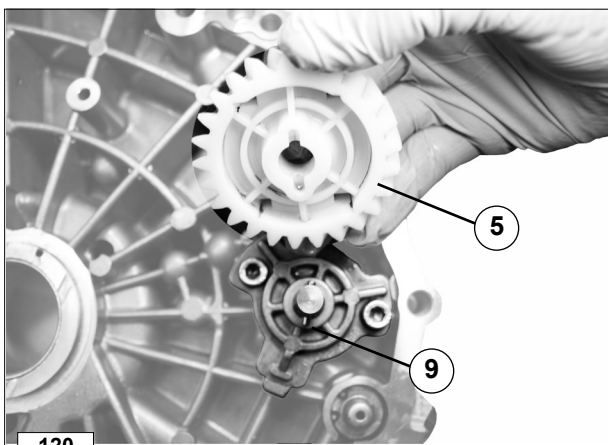

Assemble governor gear 5 by inserting drive pin 9 into its seat on the gear.

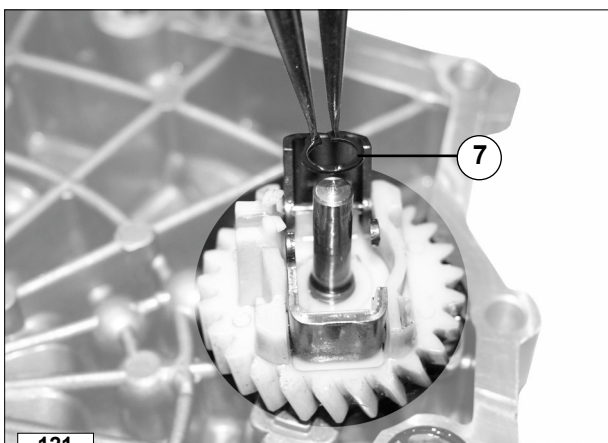

Assemble governor lock tension washer 7.

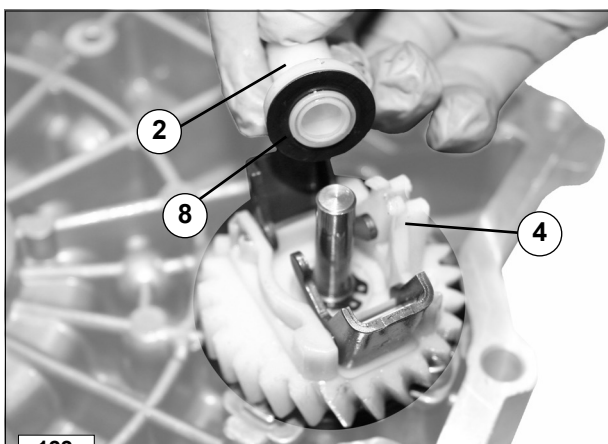

Insert drive rod 2 with clearance shim 8 forcing the clamping teeth on drive collar 4.

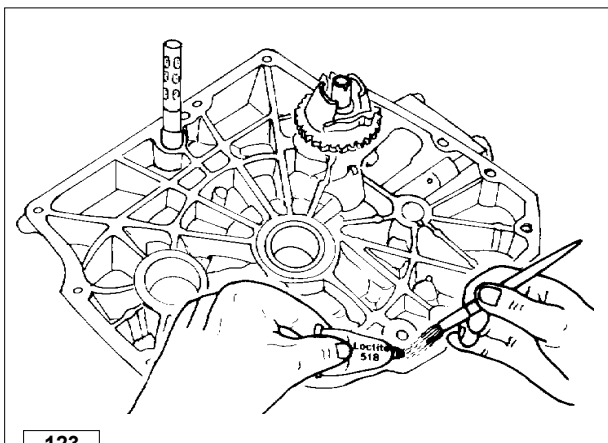

Gear cover on timing side

Proper sealing between gear cover and crankcase is ensured by the liquid sealant "Loctite 5205". Carefully clean the two sealing surfaces and spread the sealant uniformly.

○ Tighten screws to 23 Nm.

Caution – Warning
 Wait 3 hours before starting again the engine.

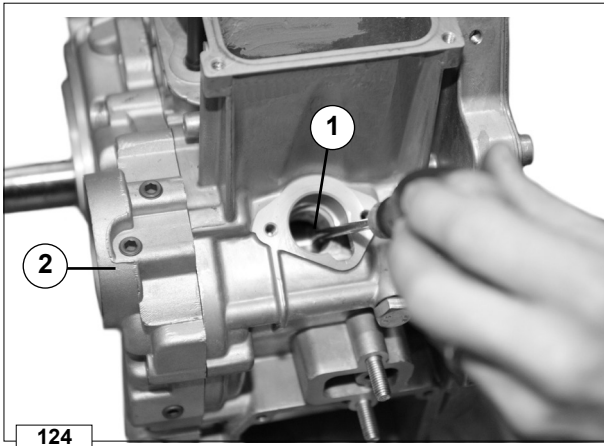

Camshaft end play

Temporarily fit camshaft **1** complete with washer; tighten gear cover **2** to 25 Nm.
Check end play by moving the camshaft back and forth using a suitable tool; the end play value is 0.10 ± 0.25 mm and is not adjustable.
In case of excessive clearance, replace the camshaft and the timing cover.

124

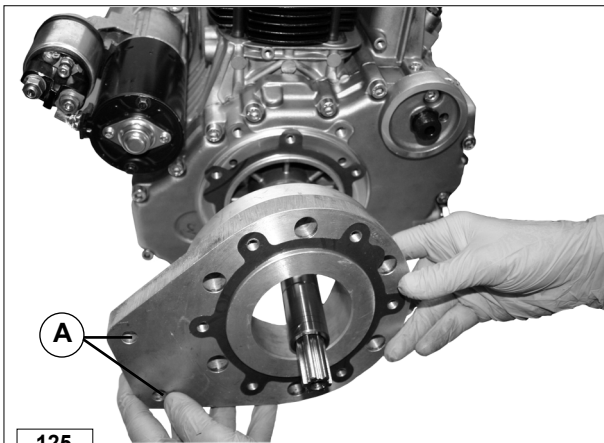

Gearbox extension, intermediate flange

Assemble the gasket on the timing cover.
Assemble the intermediate flange with gearbox fixing holes **A** facing the starting motor side.
Tighten the fastening screws to 25 Nm.

125

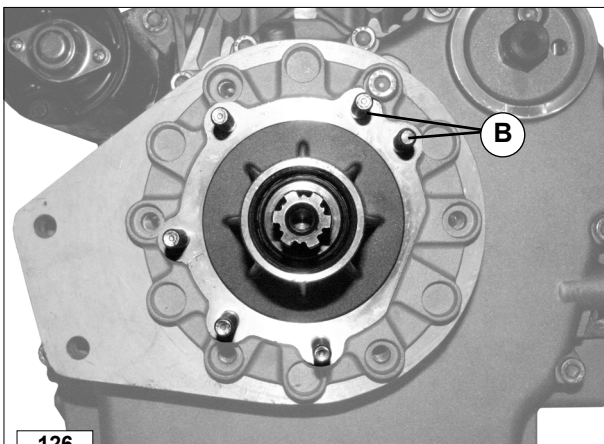

Gearbox extension

Assemble the gasket between the intermediate flange and the gearbox extension.
Assemble the gearbox extension using special tool p/n 1460-329 to avoid damaging the oil seal rings, and taking care that the gearbox fastening flange is correctly positioned with stud bolts **B** facing the oil filter.
Tighten the fastening screws to 25 Nm.

126

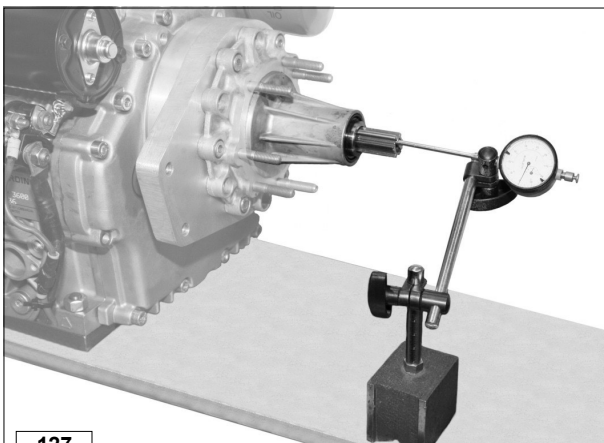

Crankshaft end play

Secure the engine to a metal base or table. Use a dial indicator with column and magnetic base plate. Place the stylus on the crankshaft.
Push and pull the driving shaft on the flywheel side.
End play should be 0.05 ± 0.25 mm; it is not adjustable.
In case of excessive clearance, replace the clearance shims.

127

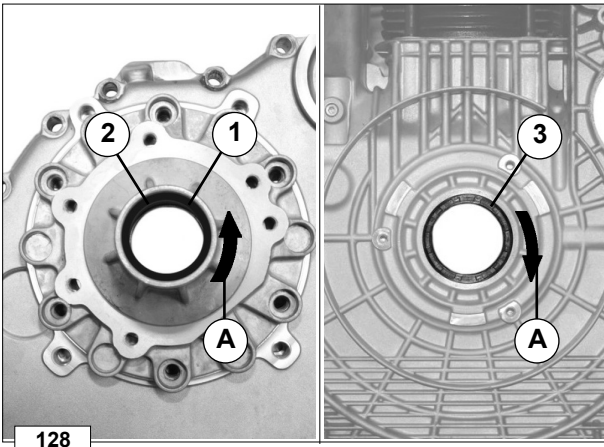

Oil seals, crankshaft - Replacement

It is possible to replace the oil seal rings if the crankshaft is assembled by following the instructions below.

Caution – Warning

A warped oil seals may allow the introduction of air into the engine thus causing crankcase ventilation problems. Use genuine oil seals.

Oil seal rings 1 and 2 are inserted in the timing cover side while ring 3 in the crankcase flywheel side.

Arrows A show the crankshaft rotation direction.

Drive the rings into their seats with a buffer exercising a uniform pressure on the whole front surface, after lubricating them generously.

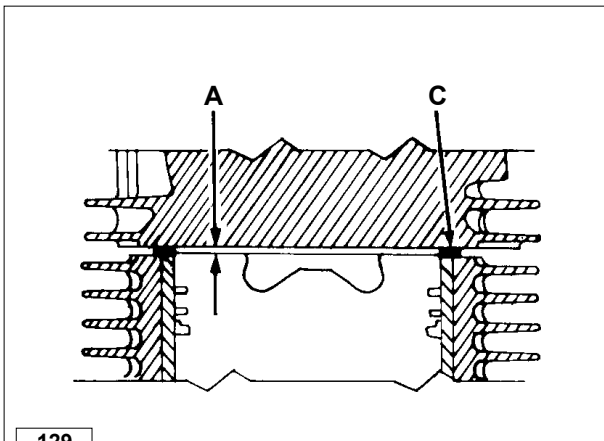

Assessing head gasket thickness

- A = Clearance
- C = Head gasket

The thickness of gasket C determines the clearance A, which must be 0.45÷0.50 mm.

For the correct thickness of gasket C see table "Head gasket" on page 47.

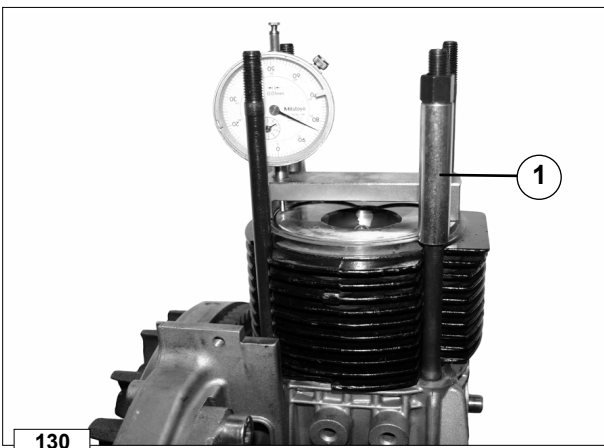

Piston protrusion check

To calculate the right thickness for the gasket, the protrusion between the piston and the cylinder head surface must be measured.

Lock the cylinder with spacers 1.

Use a dial indicator with base plate. Reset to zero while resting on a surface plate, then position against the cylinder head base plane as shown in the diagram, so that the dial indicator rod rests against the piston. Now take the reading.

Repeat the operation in the other three points (going crosswise) and take the readings. Calculate the average of these four readings to get the precise measurement of the protrusion between the piston and the cylinder head base plane.

Choose the appropriate gasket according to the following table.

Head gasket (mm)

Piston protusion	Gasket Thickness
0.250÷0.300	0.70
0.301÷0.350	0.75
0.351÷0.400	0.80
0.401÷0.450	0.85
0.451÷0.500	0.90
0.501÷0.550	0.95
0.551÷0.600	1.00
0.601÷0.650	1.05
0.651÷0.700	1.10
0.701÷0.750	1.15
0.751÷0.800	1.20
0.801÷0.850	1.25

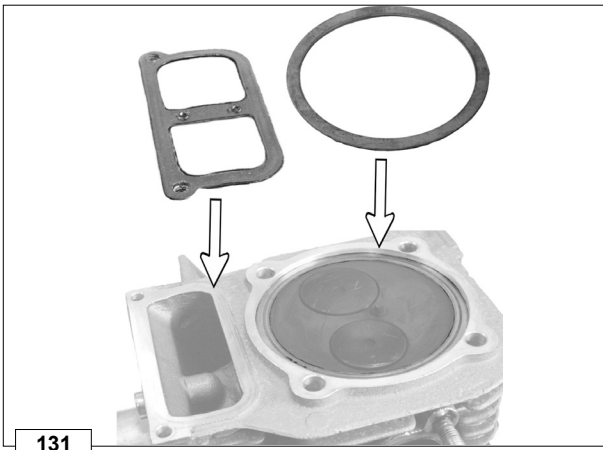

131

Having chosen the required thickness, mount the gasket as shown in the figure.

Together with the head gasket, assemble the pushrod gasket.

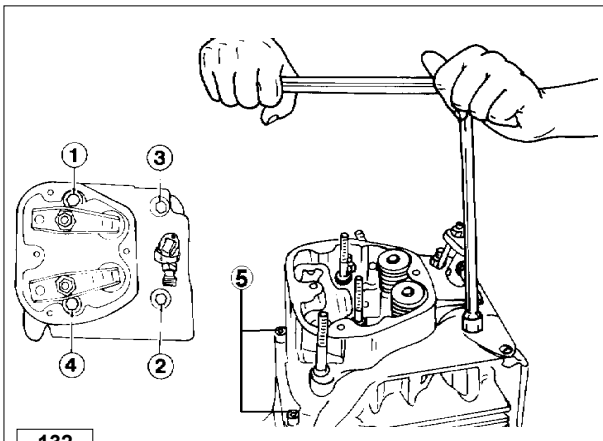

132

Head tightening



Caution – Warning

Lubricate the nuts and the washers with engine oil.

Follow the order shown in the figure to tighten the 4 nuts M9 at different stages with a torque wrench.

1st phase: tighten all nuts cross way to 5 Nm

2nd phase: tighten all nuts in the same order to 20Nm

3rd phase: tighten all nuts in the same order to 30Nm

4th phase: tighten all nuts in the same order with further rotation of 90°.

Tighten the 2 side nuts M6 to 10 Nm.

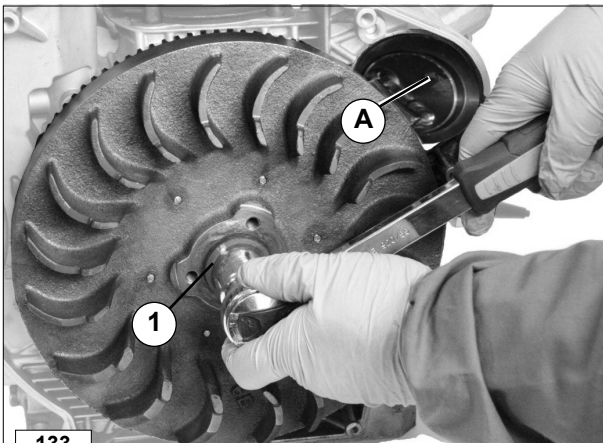

133

Flywheel



Danger – Attention

During the assembly phase, pay particular attention to prevent the flywheel from dropping as this could seriously injure the operator.

Wear protective goggles when removing the flywheel ring.



Important

Assemble the flywheel onto the crankshaft taking care that the reference key is correctly inserted into its seat on the flywheel.

Assemble special tool **A** p/n 1460-330 to lock the rotation of the flywheel in its housing in the starting motor.

Tighten bolt **1** counterclockwise.

○ Tighten bolt **1** to 150 Nm.

Remove the flywheel locking tool and install the starting motor.

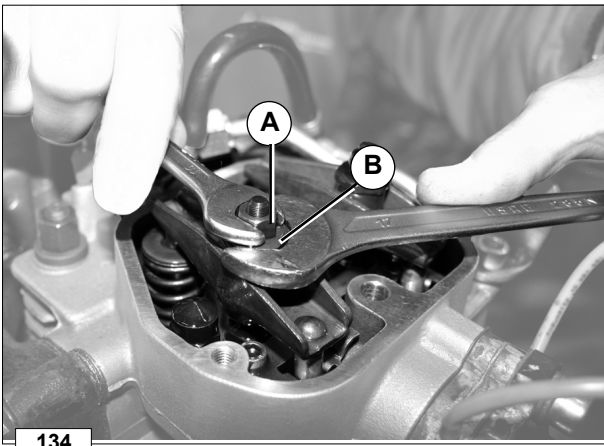

134

Valve/rocker arm clearance

 **Caution – Warning**

Adjust the valve/rocker arm clearance when the engine is cold.

Turn the engine clockwise and place the piston at the TDC. Loosen lock nut **A** while locking lock nut **B** in its position, as shown in the figure.

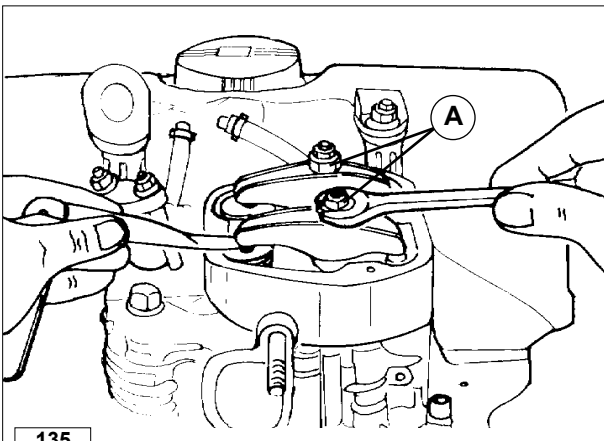

135

Set clearance at 0.10±0.15 mm using a thickness gauge.

- Tighten lock nut **A** at a torque of 7 Nm.

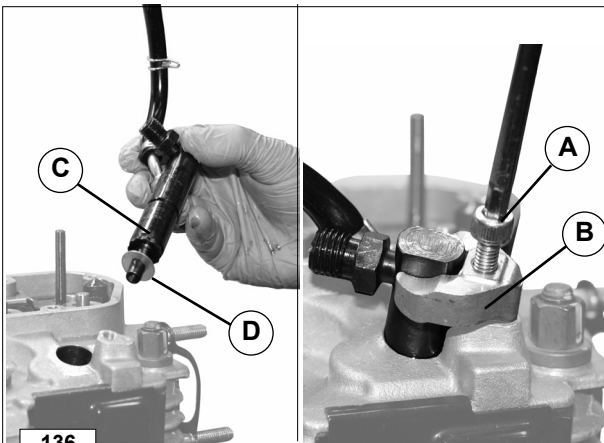

136

Injector

Assemble injector **C** together with copper seal **D**. Tighten injector bracket **B** fastening screw **A** to the cylinder head to a torque of 9 Nm.

 **Important**  **Caution – Warning**

The correct protrusion of the spray nozzle from the cylinder head surface is obtained with copper seal **D** available in the following thicknesses: 0.5, 1 and 1.5 mm.

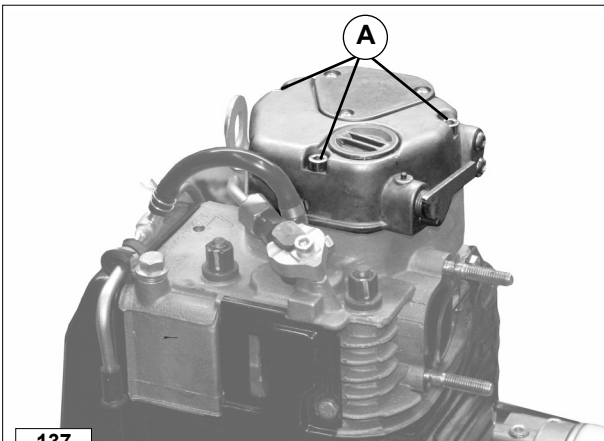

137

Rocker arm cover

Replace the seal and assemble the rocker arm cover by tightening the 3 screws **A** to a torque of 10 Nm.

! Danger – Attention

The engine can be damaged if allowed to operate with insufficient oil. It is also dangerous to add too much oil because its combustion may lead to a sharp increase in the rotation speed.

Use suitable oil in order to protect the engine.

Nothing more than lubrication oil can influence the performances and life of an engine.

Use of an inferior quality oil or failure to regularly change the oil will increase the risk of piston seizure, will cause the piston rings to jam and will lead to rapid wear on the cylinder liner, the bearings and all other moving parts. Engine life will also be notably reduced. The oil viscosity must suit the ambient temperature in which the engine operates.

! Danger – Attention

Old engine oil can cause skin cancer if repeatedly left in contact with the skin and for long periods of time. Wear protective gloves to avoid touching used oil. If contact with the oil is unavoidable, you are advised to wash your hands with soap and water as soon as possible. Dispose of old oil in the correct way as it is highly polluting.

LUBRICATION SYSTEM

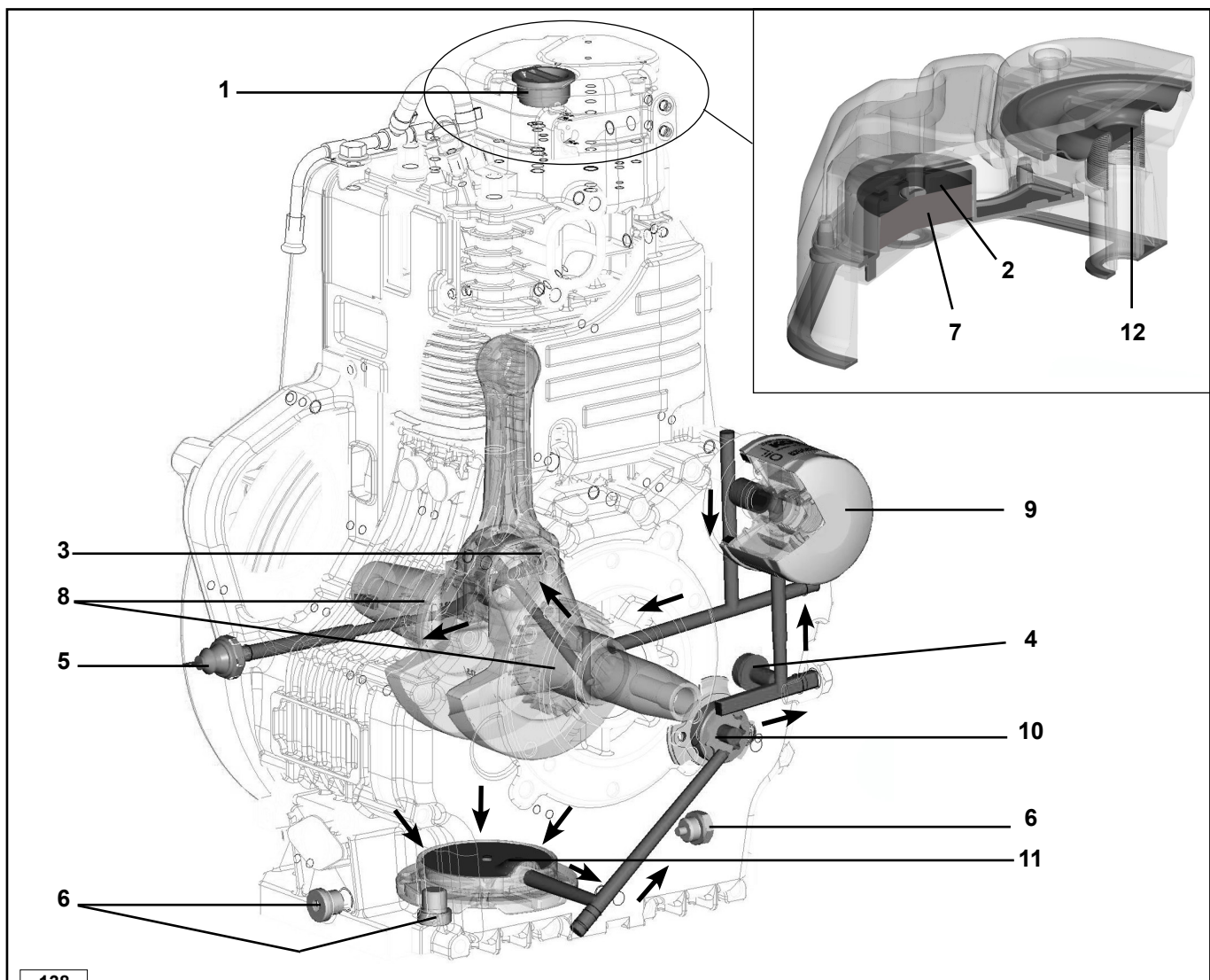

138

Components:

- | | | |
|---------------------------|-------------------------|-----------------------|
| 1) Oil fill cap | 6) Oil drain plug | 11) Oil intake filter |
| 2) Safety valve | 7) Oil vapour separator | 12) Safety valve |
| 3) Rod journal | 8) Main journal | |
| 4) Pressure control valve | 9) Oil filter | |
| 5) Pressure gauge | 10) Oil pump | |

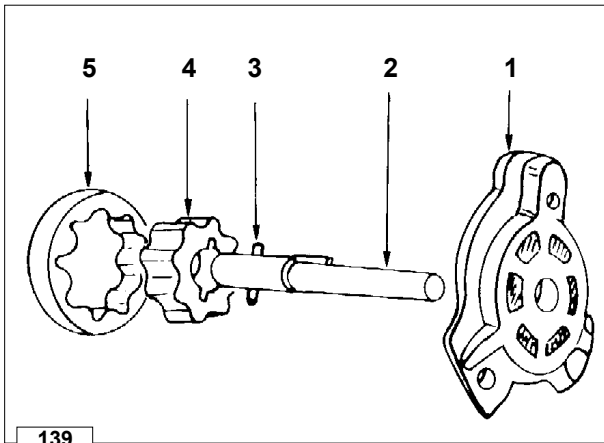

139

Oil pump

Components:

- 1 Cover
- 2 Shaft
- 3 Key
- 4 Pin
- 5 Internal rotor
- 6 External rotor

Oil pump delivery at 3000 rpm is 5.8 l/min.

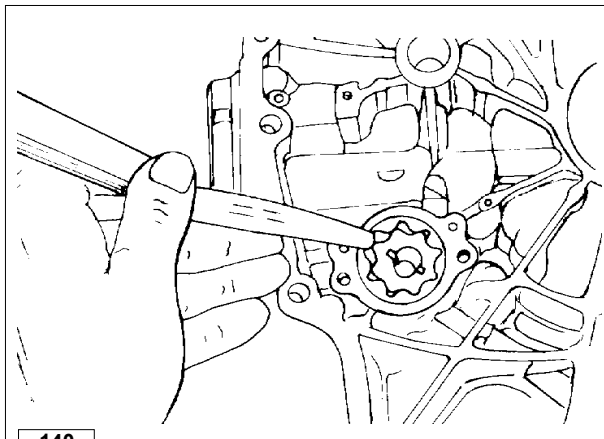

140

Oil pump - Clearance between rotors

Measure clearance as shown in the figure; the max. value is 0.13 mm; wear limit 0.25 mm.

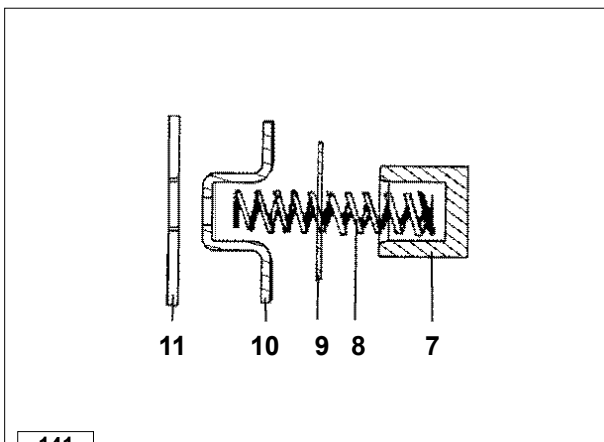

141

Oil pressure regulation valve

Components

- 7 Plunger
- 8 Spring
- 9 Washer
- 10 Cup
- 11 Snap ring

 Free length **A** of the spring is 25.50±25.75 mm.

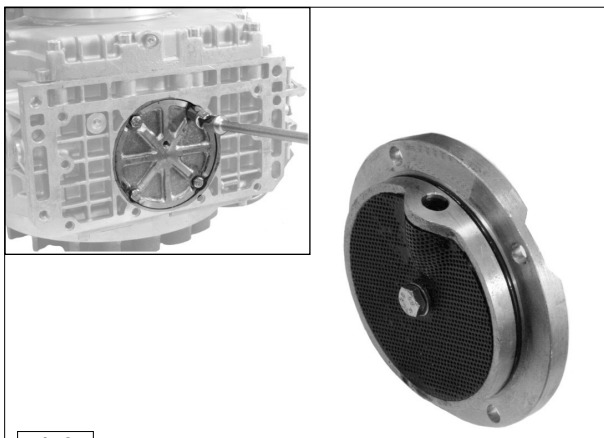
Note: If **A** is 1 mm less than the given value, replace the valve.
Valve setting is not adjustable.

142

Internal strainer

Placed inside the bottom cap (see figure).

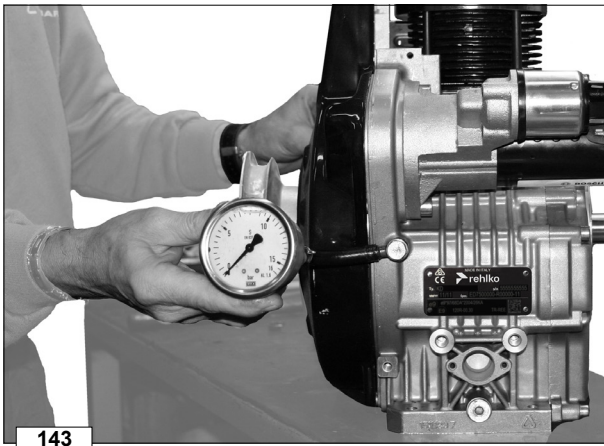

143

Oil pressure check

Connect a 10 bar pressure gauge to the oil filter fitting. Start the engine and check pressure as a function of the oil temperature (see below).

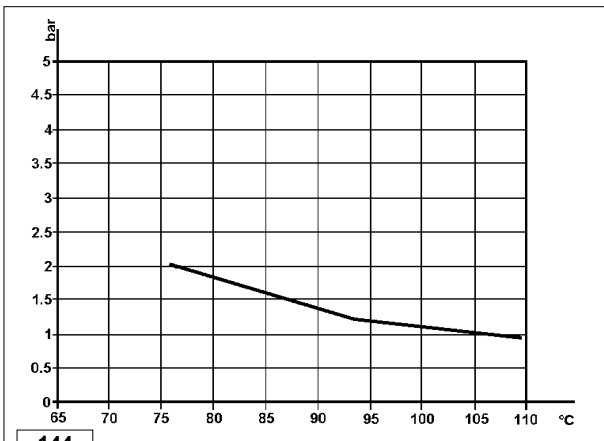

144

Oil pressure curve at idle rotation speed

The curve is obtained with engine running at a constant speed of 1200 r.p.m. in no-load conditions; pressure is given in bar and temperature in centigrades.

The curve represents the minimum pressure value.

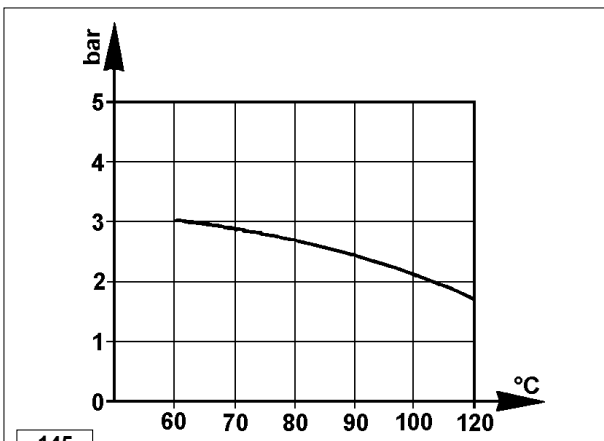

145

Oil pressure curve at full rotation speed

The curve is obtained with engine running at 3600 r.p.m. at the N power; pressure is given in bar and temperature in centigrades.

The curve represents the minimum pressure value.

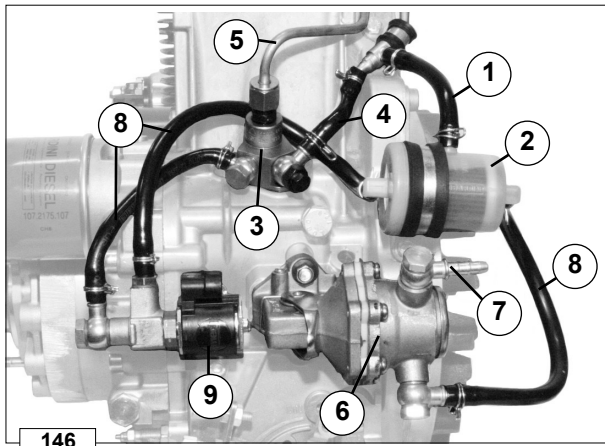

Fuelling/injection circuit

Components:

- 1 Fuel filter return tube
- 2 Fuel filter
- 3 Injection pump
- 4 Injector pump exhaust pipe
- 5 High pressure line
- 6 Fuel lift pump
- 7 Fuel pump suction (to be connected to the tank)
- 8 Fuel feeding tubes
- 9 Solenoid valve

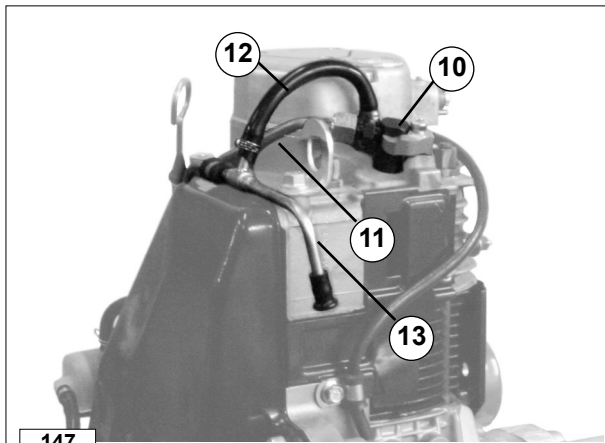

- 10 Injector
- 11 High pressure line
- 12 Injector leak-off line
- 13 Fuel overflow pipe (to be connected to the tank)

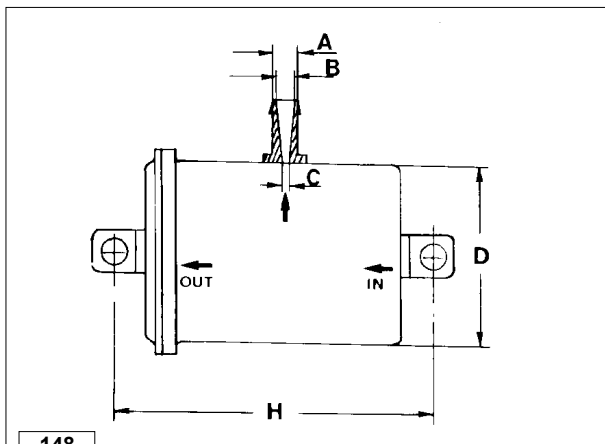

Fuel filter

Dimension (mm)

A	B	C	D	H
7.3	3.8÷3.81	1÷1.2	42	75

Characteristics: Filtering area..... $\geq 390 \text{ cm}^2$
Filtration level..... $\leq 7 \mu\text{m}$

See page 14 for fuel filter replacement.

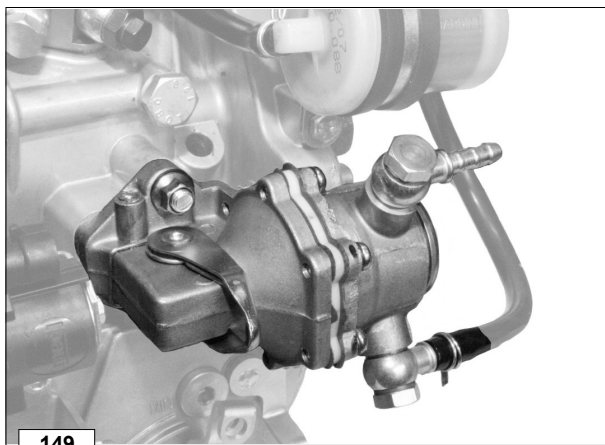

Fuel lift pump

The pump is the diaphragm type and is operated by a camshaft eccentric through a drive rod.
Tighten screws to 15 Nm.

Characteristics:

At 2000 rpm of the camshaft, the minimum delivery is 40 l/h, while the automatic adjustment pressure is $0.5 \div 0.7 \text{ bars}$.

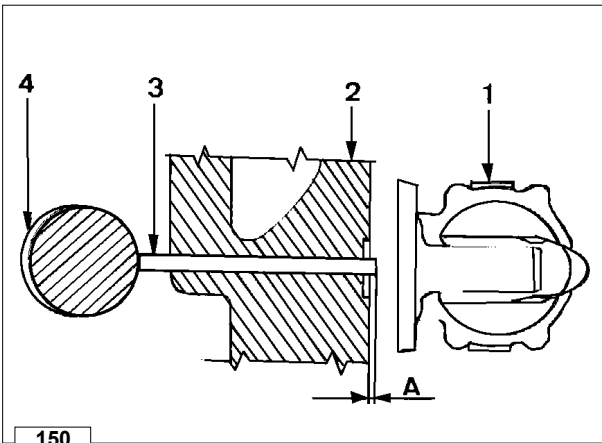

Fuel pump, drive rod protrusion

Components:

- 1 Fuel pump
- 2 Crankcase
- 3 Drive rod
- 4 Eccentric

Check while eccentric 4 is at rest (lowest point of travel).
Protrusion A of drive rod 3 is 1.5÷1.9 mm; it is not adjustable.
Replace the drive rod if it does not comply with tolerance.

Drive rod length 70.8÷80.0 mm

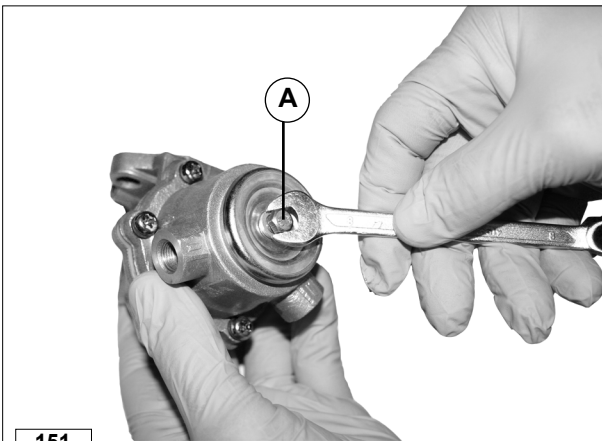

Fuel lift pump - Filter cleaning

To clean the fuel pump filter loosen screw A.

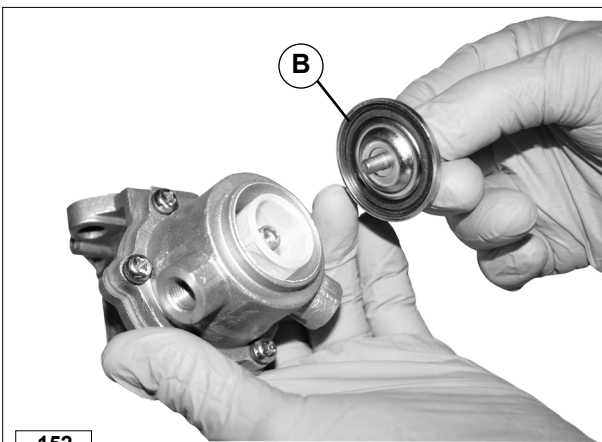

Remove the fuel pump cover B.

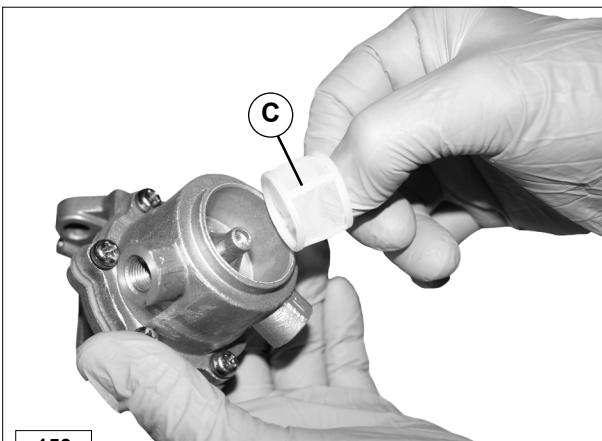

Pull out the filter C.
Clean the filter, put it back in seat, mount the fuel pump cover and
retighten the screw to 4.5 Nm.

Solenoid valve

Dimensions (mm)

F	G
10	10

Characteristics:
12 V 0.9 A.

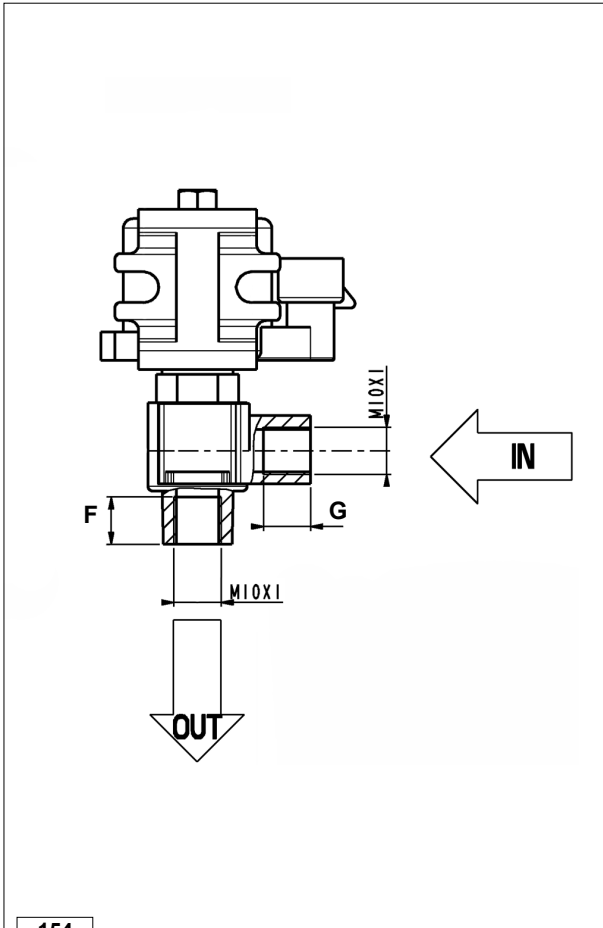

Injection pump

This is of the simplified QLC type; it is housed in the crankcase and is controlled by the camshaft via tappets.

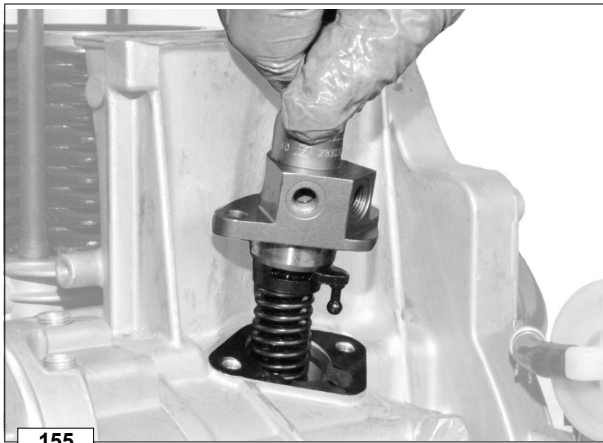

Injection pump fitting in the crankcase

Fit pad 2 into the tappet so that recess B points downwards as shown in the figure. (For pad spacer, see fig. 165)
Fit the injection pump into the crankcase complete with gasket positioning flow control 1 in the fork of lever 5 which should be in the maximum flow position.

Caution – Warning

When removing the injection pump from its housing make sure that spacer 2 is not dropped into the oil sump; injection pump operation will be hampered if the spacer is not installed.

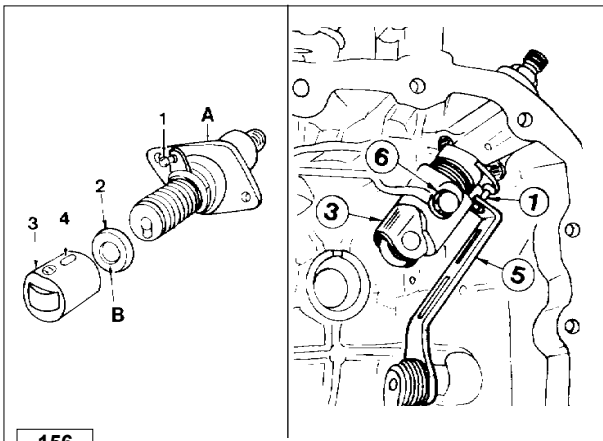

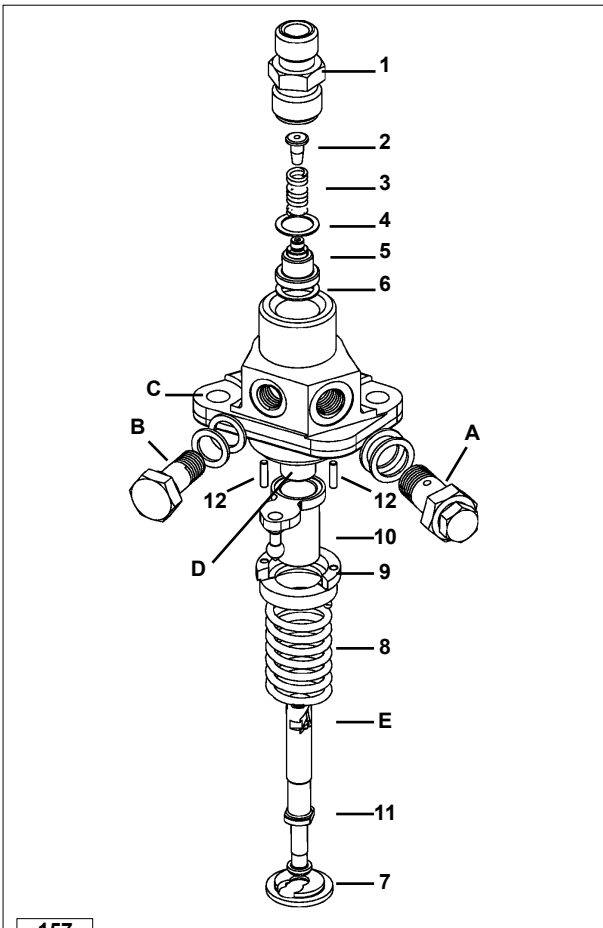

157

Injection pump components and disassembly

- 1 Delivery union
- 2 Filler
- 3 Spring
- 4 Gasket
- 5 Delivery valve
- 6 Gasket
- 7 Spring retainer
- 8 Spring
- 9 Sleeve
- 10 Rack
- 11 Piston (pumping element)
- 12 Pin

- A Fuel exhaust union screw with non-return valve
- B Fuel inlet union screw
- C Fastening
- D Plunger barrel (in the injection pump case)
- E RH helix

Demount in compliance with the numeric order.
 Plate 9 is held firm by pins 12. Lever up by inserting a tool between the plate and the body of the pump.
 The volume shifted by delivery valve 5 is 21 mm³.

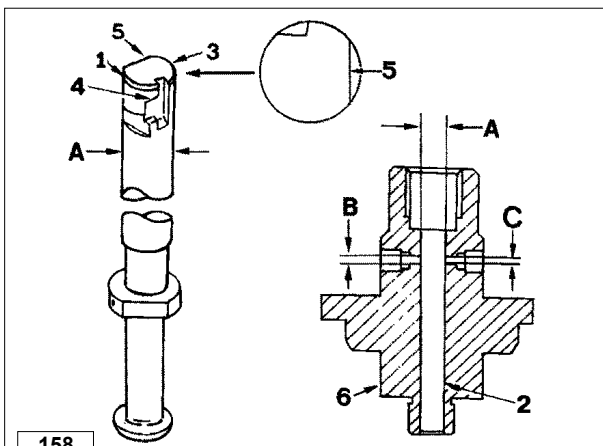

158

Injection pump, body, plunger and delivery valve

Components:

- 1 Collar
- 2 Barrel
- 3 Piston (or pumping element)
- 4 Right helix
- 5 Delay notch
- 6 Pump body
- B Inlet hole
- C Exhaust hole

Dimensions mm:
 A = 7.00 (nominal diam.)
 B = 2.00÷ 2.03
 C = 1.50÷1.53

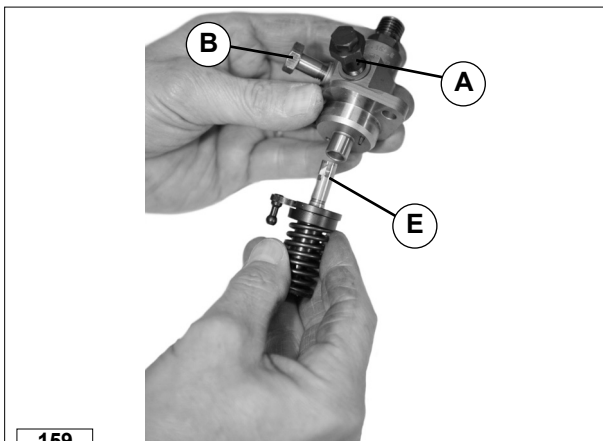

159

Injection pump refitting

The plunger is fitted with helix E facing towards the outlet union A; if it is mistakenly fitted with the helix facing the intake coupling B the injection pump no longer operates (there is no danger of engine run-away); complete refitting following fig. 136.

Injection pump non-return valve

In the exhaust union screw there is a non-return valve. The purpose of this valve is to improve the injection phase by expelling the air in the fuel and preventing it from being sucked in by the pump during the intake phase. This also ensures that the engine stops promptly as soon as the stopping device is activated by means of the solenoid valve.

Outlet fitting components with non-return valve

- 1 Outlet fitting
- 2 Ball Ø3.968 mm
- 3 Threaded screw
- 4 Ball retaining seat
- 5 Exhaust holes

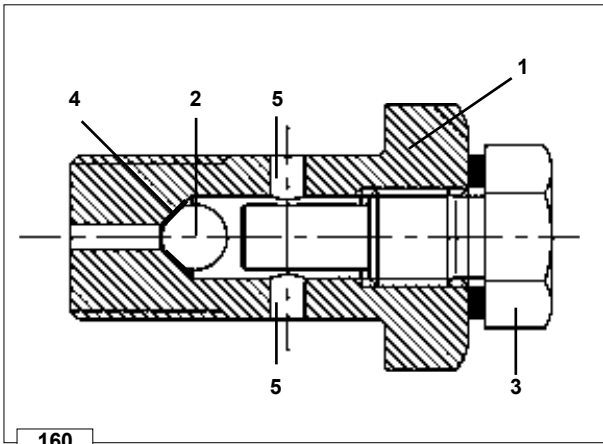

160

Static injection timing

- 1 - Disconnect the pipe from injection pump outlet 1.
- 2 - In its place, assemble a clear nylon hose 2 as shown in the figure.
- 3 - Insert a metal wire, protruding about 10 mm, into the hose to allow an easier check of fuel leaks.
- 4 - Connect the injection pump intake 3 with a hose 4 to an auxiliary tank placed at about 50 cm higher than injection pump.
- 5 - Fill the tank with the fuel
- 6 - Set the flow governor lever of the injection pump in the stop position and lock it there.

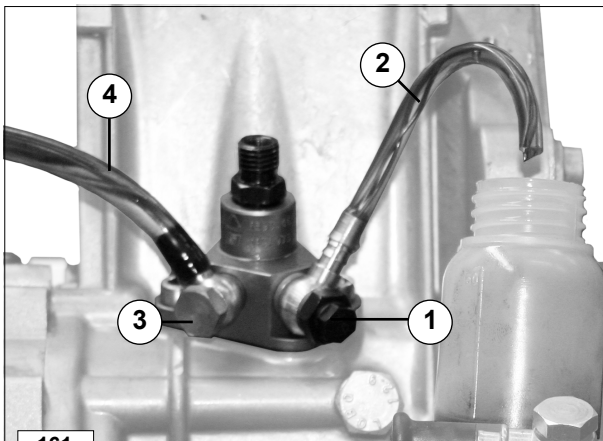

161

- 7 - Turn the flywheel in the engine rotation direction.

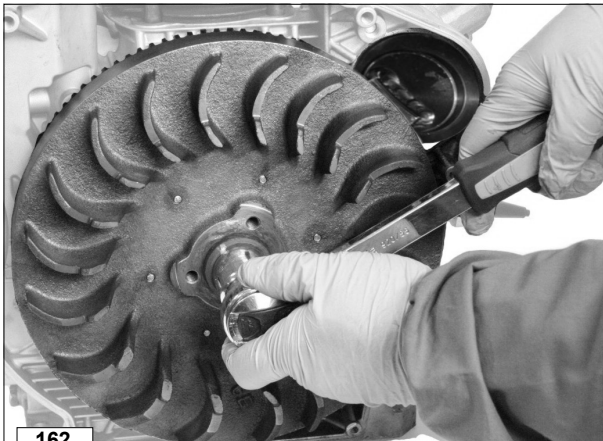

162

- 8 - Proceed slowly during the compression phase. The fuel that flows from tube 2 will tend to diminish.
- 9 - Stop as soon as it ceases to drip (one drop of fuel every 30-40 seconds is tolerated).
- 10- This is the static injection lead.
- 11- Use a tape measure from above the flywheel to measure the distance between the fixed TDC reference A fig. 164 on the crankcase and the TDC reference point C on the flywheel.
- 12- Compare the value found in the "Conversion table from millimetres into degrees" to find the advance degrees.
- 13- If the value found does not match the specified value (see "Injection advance specified value" table), replace the pad below the injection pump (fig. 165)



163

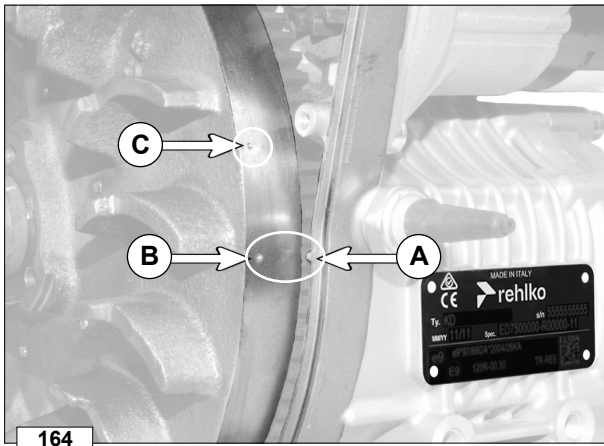

164

References on the flywheel

- A** = Reference of fixed TDC on crankcase
B = Injection lead reference on the flywheel
C = TDC reference on flywheel
 α = Reference in degrees between **B** and **C**.

Injection advance specified value

Motor type	A/C mm	α
	with external \varnothing flywheel 260	
recorded to 3600 [rpm]	27.21	12

Conversion table from millimetres into degrees

A/C mm	α
13.61	6
15.87	7
18.14	8
20.41	9
22.68	10
24.94	11
27.21	12
29.48	13
31.75	14
34.02	15

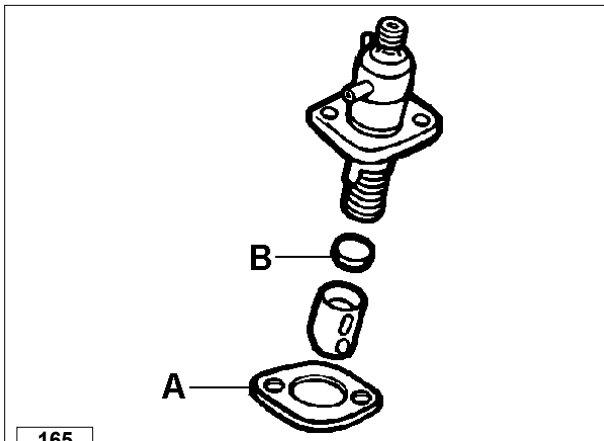

165

Injection advance adjustment

To alter the value of injection advance the pad must be replaced with another of a suitable thickness (see fig. 83÷83_a).
 To extract pad **B**, use a rod with a suction cap or magnet at one end.
 The replacement pads supplied have 10 different thicknesses (between 4.0 and 4.9mm).

Note: When the thickness of the pad varies by 0.1mm under the pump, **B** is delayed or brought forward by 1° on the flywheel.

Injector

Components:

- 1 Body
- 2 Union
- 3 Adjusting shim
- 4 Spring
- 5 Pressure rod
- 6 Pin
- 7 Nozzle
- 8 Nozzle cup
- 9 Needle valve
- 10 Tip
- 11 Duct
- 12 Return hole

After re-assembly, tighten ring nut 8 to a 50 Nm torque value.

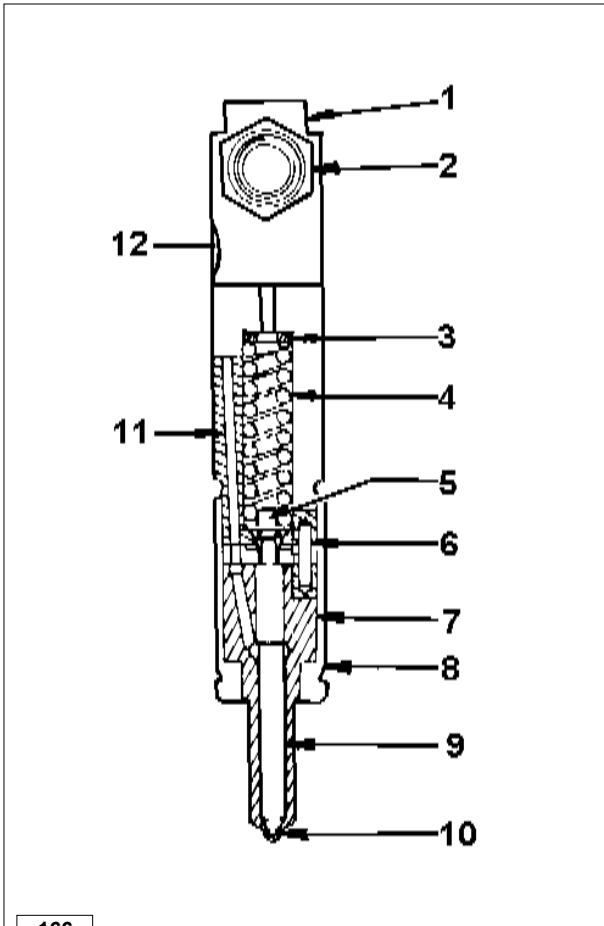

166

Bar filter

Bar filter **A** is a filter inside the injector inlet union. If obstructed, replace the inlet union together with the bar filter.

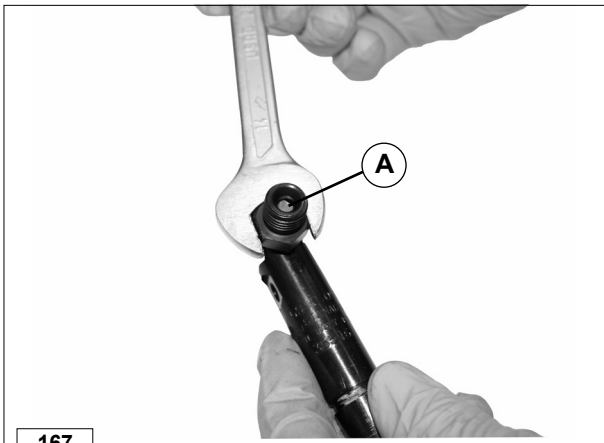

167

Replace inlet union **B** and gasket **C**.



Important

The bar filter cannot be cleaned. The inlet union and the gasket must be therefore replaced.

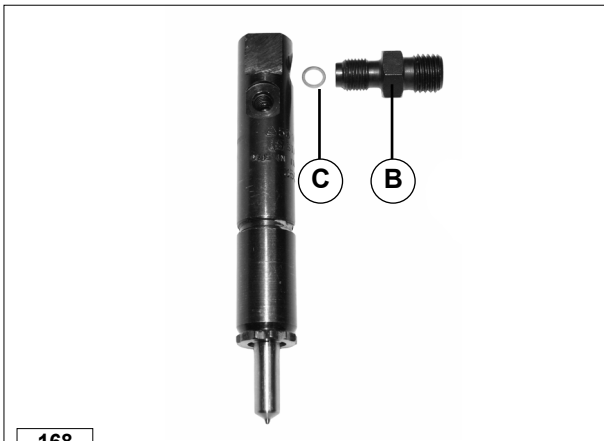

168

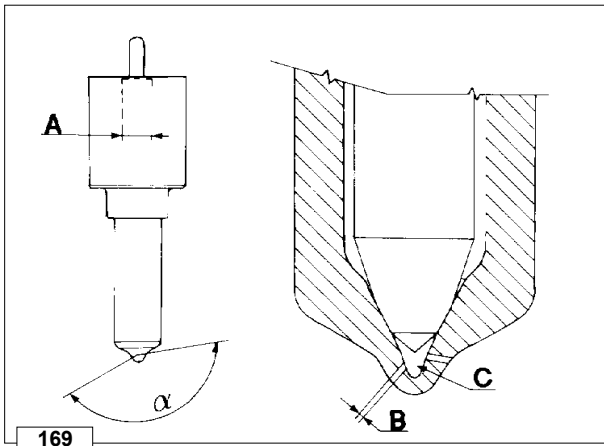

169

Nozzles

The set-up between the needle and the guide must leave the needle free to fall and merely as a result of its own weight, when lifted 7mm from its seat and rotated in different directions, with the nozzle kept at a 45° angle.

Rotation of the needle must be completely smooth and uninhibited by obstacles and malformations.

Moreover, on being squeezed against its seat, it must fall freely, when the nozzle is inverted.

The test must be carried out after rinsing both the needle and nozzle with trichloroethane and wetting with AGIP FANUM FLUID CD.

A	4.5
B (n° and diam. of holes)	5 x 0.150
hole length	0.8
α	160°
pin height	0.375÷0.425
C sump volume	0 mm ³
Pressure (bar)	255÷263

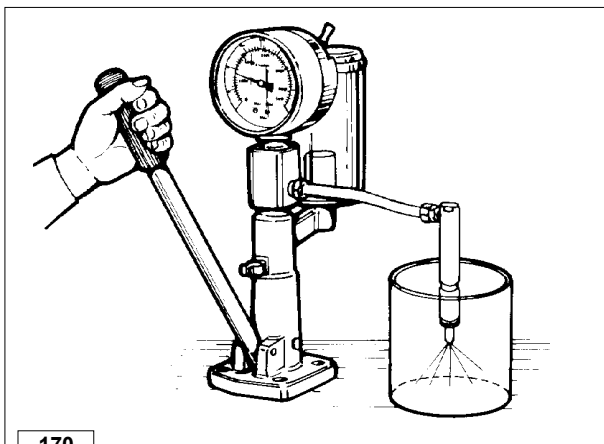

170

Injector calibration

Connect the injector to a manual pump and adjust the setting pressure, if necessary, by modifying adjusting shim 3 fig. 145 above the spring.

When the spring is replaced, calibration must be carried out at a pressure higher than 10 bars to counterbalance adjustments while running.

Spraying and opening pressure

With the pressure gauge closed, press hard on the hand pump at least 10 times.

Open the pressure gauge and press down on the pump once every second, while keeping a check on the spraying process and pressure. The opening pressure must lie between the two values given in the table. Jets must be uniform and well distributed.

Leakage time (waste)

Pressure must drop from 150 to 100 bars in a span of not less than 8 seconds and not more than 30.

Seat seal

Nozzle tip wet.

Pressure must be kept 20 bars below the opening pressure for 10 seconds.

After this time, dampness on the nozzle tip is acceptable, and may be identified by touching with a dry finger. Only a drop of dampness is acceptable and not a large thick patch which would indicate a leak.

12V, 17A electric ignition diagram

Components:

- 1 Alternator
- 2 Starter motor
- 3 Voltage regulator
- 4 Battery
- 5 Oil pressure switch
- 6 Oil pressure light
- 7 Key switch
- 8 Battery charging light
- 9 Capacity bank
- 10 Push button switch

Note: The battery, which is not supplied, should have 12V nominal voltage rating and a capacity of not less than 44 Ah / 210 Amp. of fast discharge intensity.

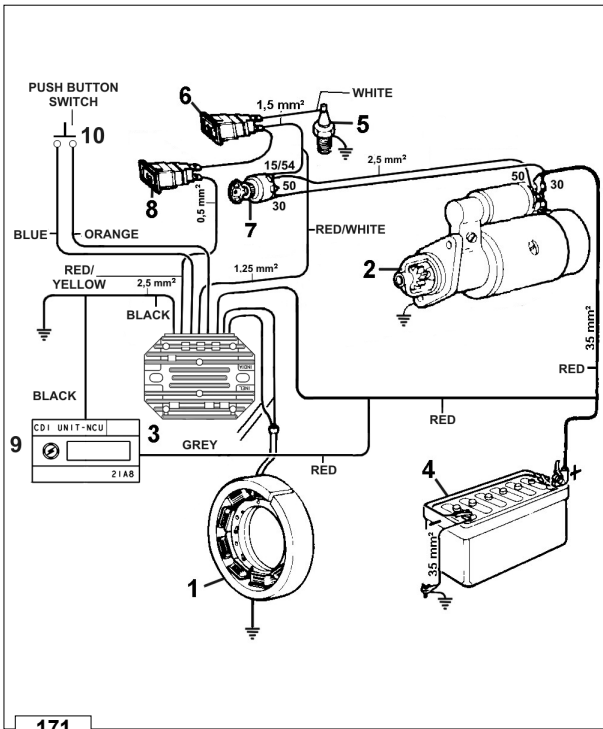

171

Alternator

Components:

- 1 Ring gear
- 2 Flywheel
- 3 Rotor
- 4 Stator

The stator fixing screws must be tightened to 1.2 Nm.

Note: The rotor is made up by a plastoferrite ring which is fixed to flywheel while the stator is mounted on the crankcase.

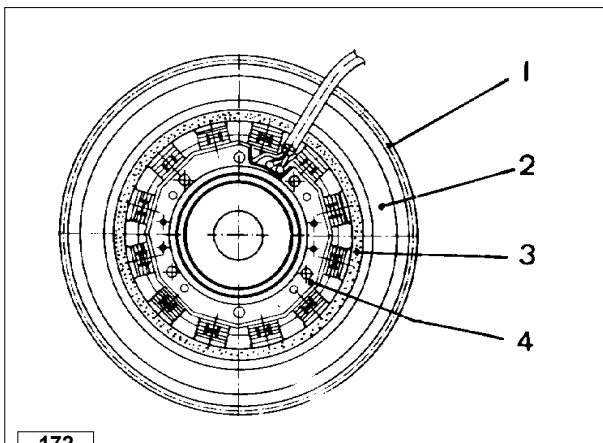

172

Alternator charger graph (12V, 17A)

This test has been carried out after thermal stabilization at 20°C for 2 minutes at 3000 r.p.m. with constant battery voltage of 12.5V. The value of the power supplied with reference to the curve may change in a range between +10% and -5%.

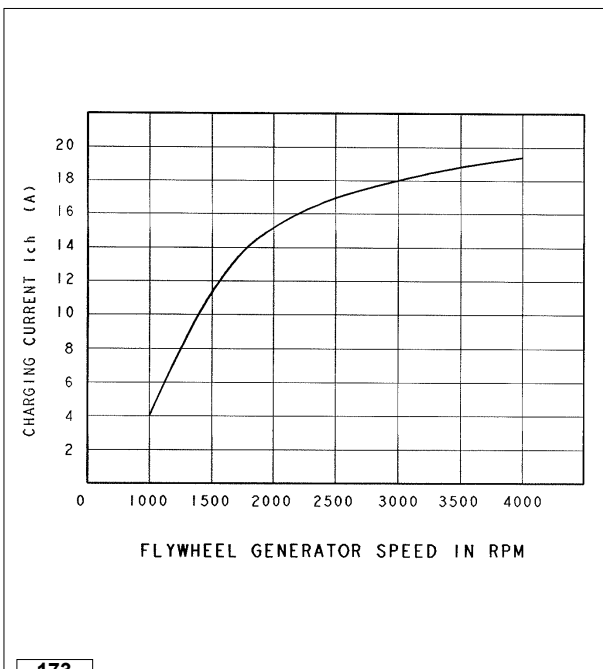

173

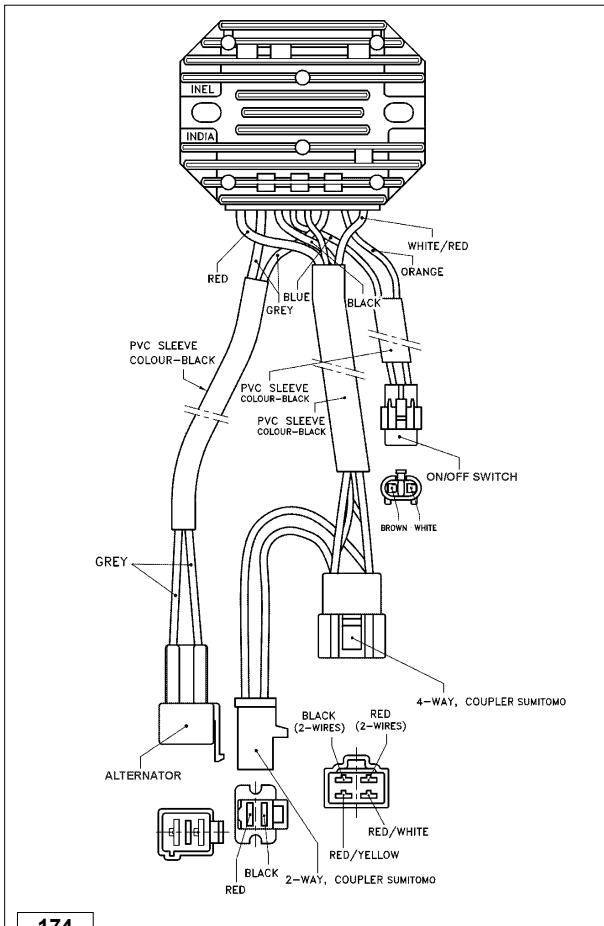

174

Voltage regulator

14.5V, 20A: for 12V, 17A alternators with 2 output wires

The tabs are in different sizes to prevent incorrect connections.



Caution – Warning

When the engine is running do not disconnect battery cables or switch key to "off" position.

Do not place the governor near heat sources, but in well ventilated areas above 75°C.

Do no electric welding on engine or application.

Connection Diagram

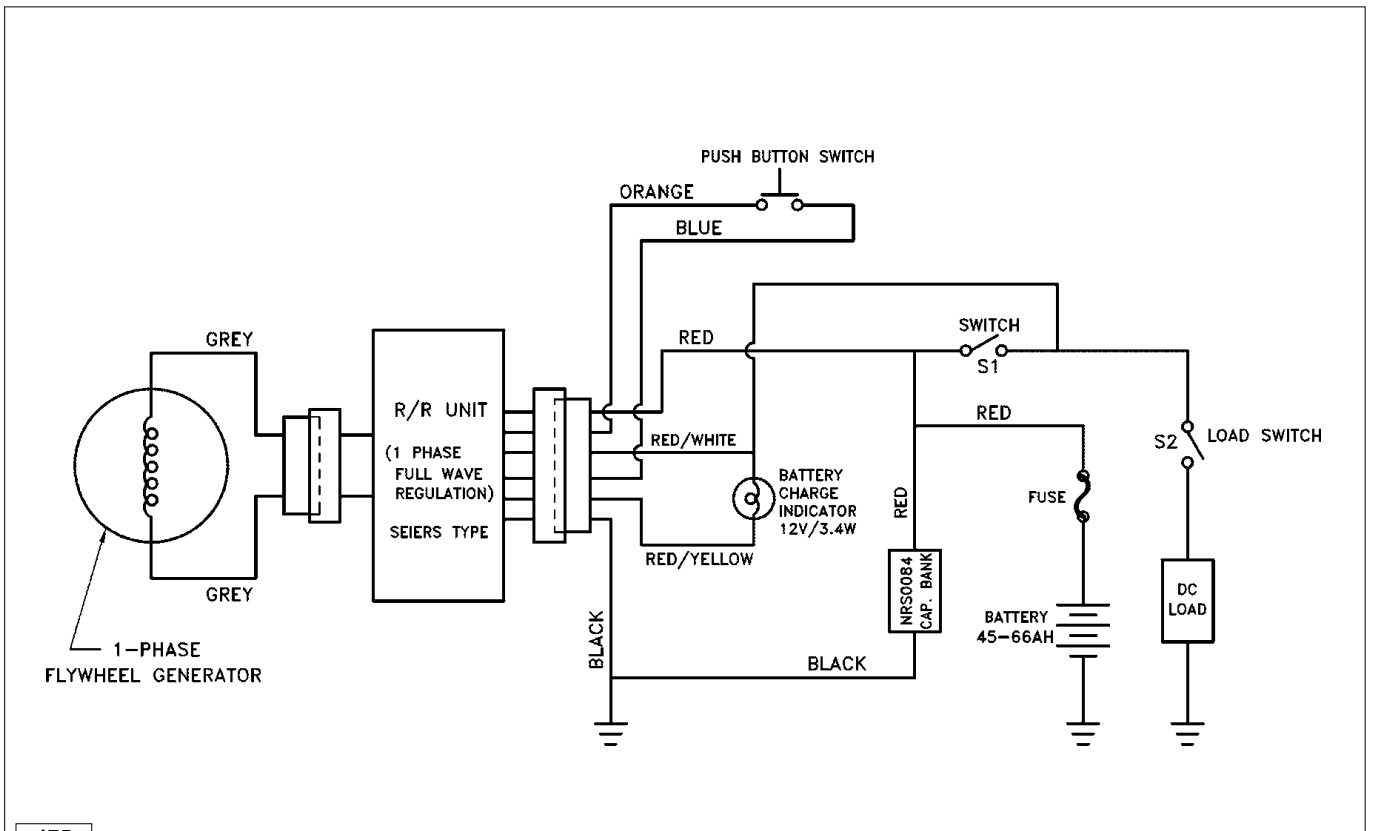

175

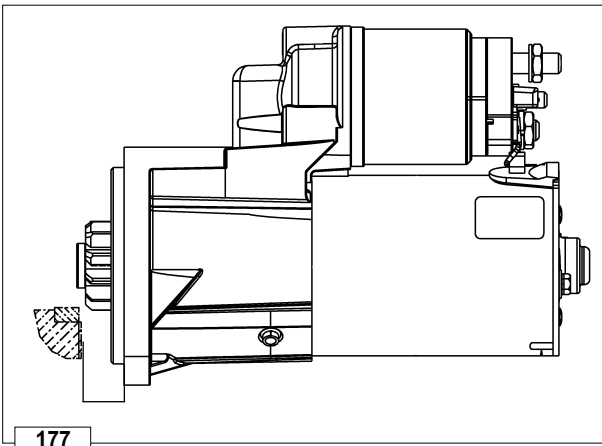

177

Starting motor - BOSCH

Anti-clockwise rotation direction (viewed from pinion side)

A = 17.5÷19.5 mm

Distance from flywheel rim surface to starter motor flange surface.

Note: Contact Bosch service centers for repair operations.

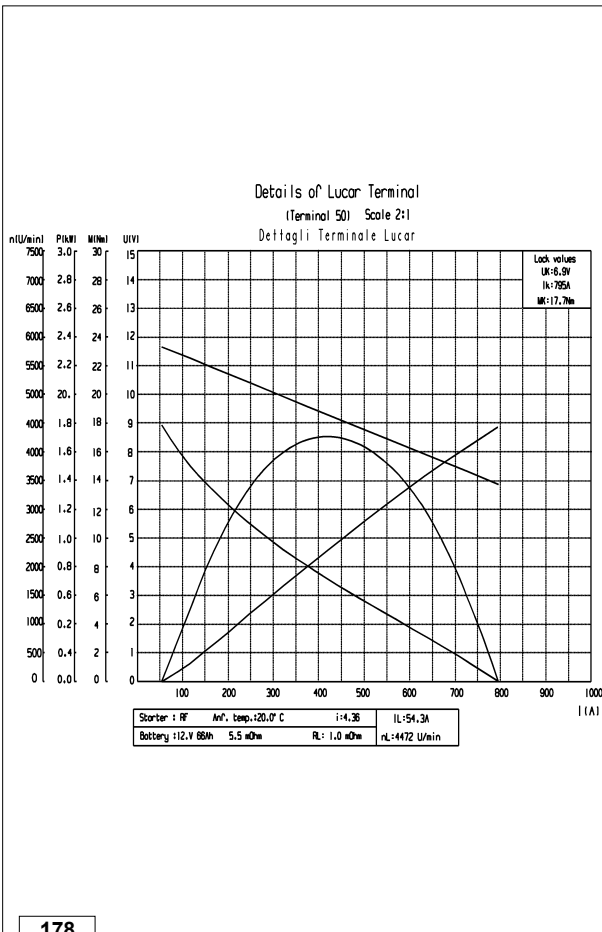

178

Characteristic curves for starting motor type BOSCH DW (L) 12V, 1.2 KW

The curves were obtained at a temperature of -20°C with 66 Ah battery.

U = Motor terminal voltage in Volts

n = Motor speed in r.p.m.

M = Torque in Nm

J(A) = Absorbed current in Ampere.

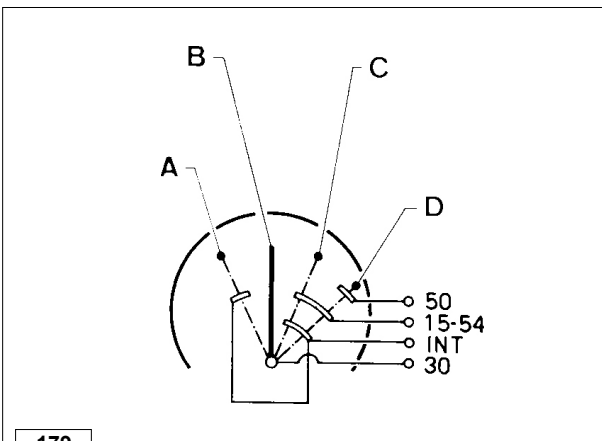

179

Ignition switch positions

A Accessory

B Off

C On

D Start

Accelerator lever for speed governor with min/max speed system

- A** Internal governor lever into control group
- B** Nut
- C** Internal accelerator lever into control group
- D** Lock ring
- E** Max. speed spring
- F** Min. speed spring

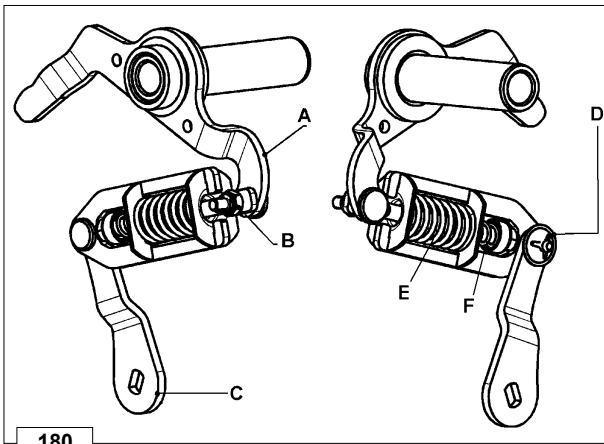

180

Assembly procedure for accelerator lever of speed governor with min/max speed system

Insert the pin in the hole on the internal accelerator lever.
Mount the lock ring on the pin.

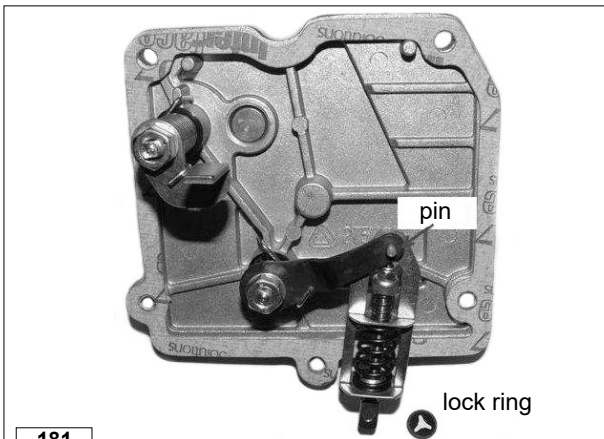

181

With a special fork tool matr.1460-341, take the min-max assembly as shown in the front and top figure.

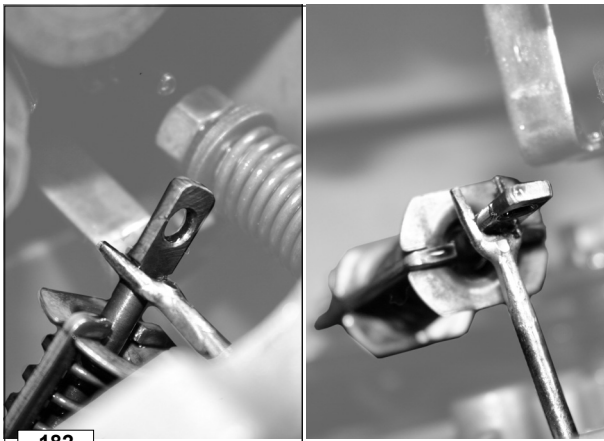

182

The threaded pin of the governor lever must enter in to the hole on the min-max assembly

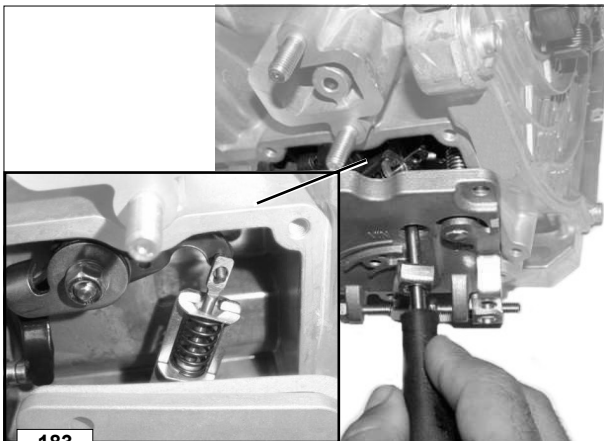

183

184

With a special tool matr.1460-342, mount the nut on the threaded pin

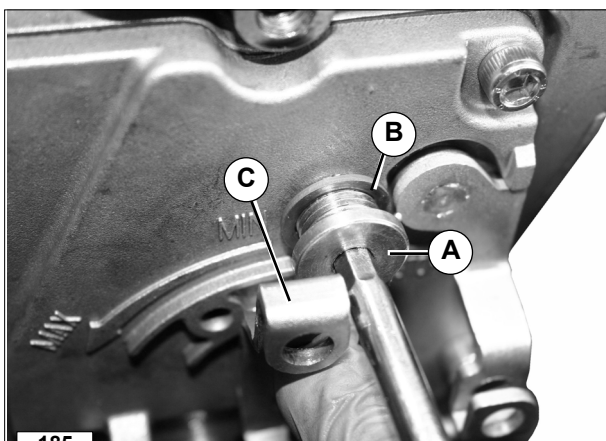

185

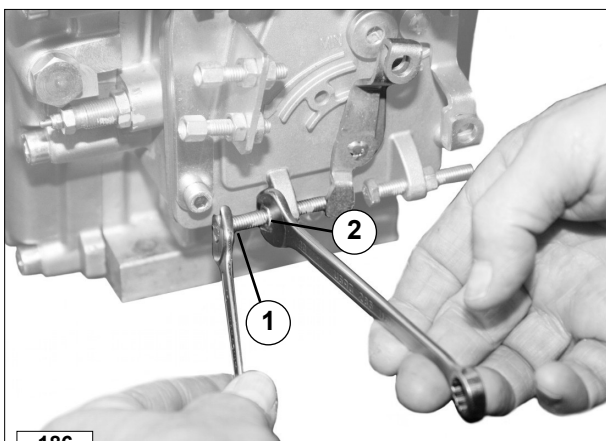
Keeping lever **C** displaced, close the hole with plug **A** and gasket **B**.

186

Setting the slow idle (standard) rotation speed

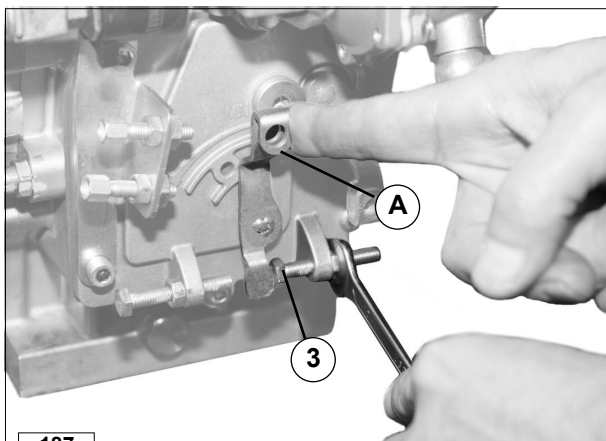
After having filled the engine with oil and fuel, start it and allow it to warm up for 10 minutes.
Using adjuster screw **1**, regulate the idling rate at 1000-1250 rpm.
Tighten the check nut **2**.

187

Setting the fast idle (standard) rotation speed

After having adjusted the idling rate, operate lever **A** to accelerate the engine.
Use screw **3** and regulate the top rate at 3800 rpm (for engines set at 3600 rpm on load).

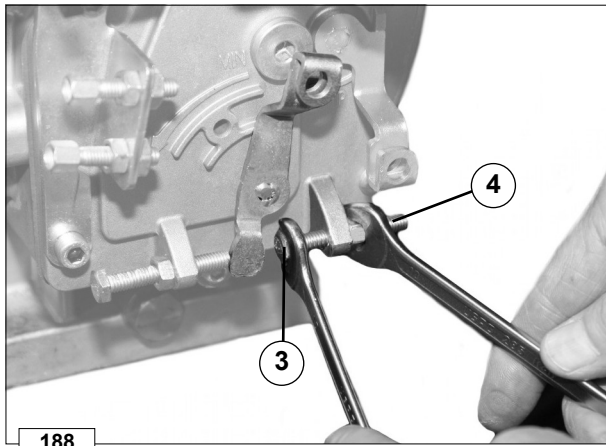

Fasten lock nut **4** keeping adjusting screw **3** in its position.

188

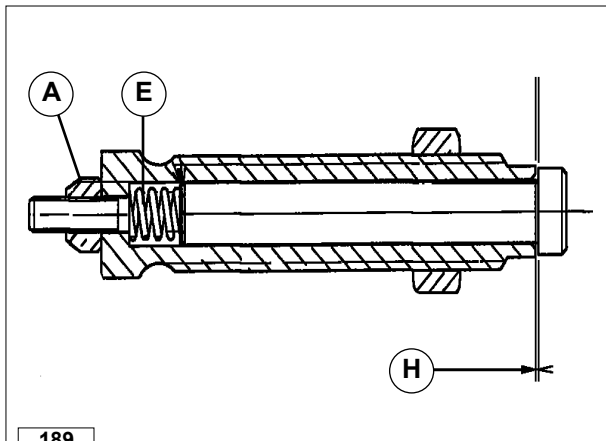

Injection pump delivery limiting and torque adapter

Delivery limiting device **C** has the function of limiting the injection pump max. delivery.

The same mechanism acts also as a torque gearing device. Indeed, under torque, spring **E** inside the limiter is compressed when subject to the action of the governor levers, by exploiting the opposed forces of the accelerator spring and of the centrifugal weights of the speed governor. Stroke **H** that the torque gearing device allows to be carried out by lever **A** is $0.25 \div 0.30$ mm. It can be adjusted by means of nut **A**, and consequently the injection pump delivery will increase under the specified set torque value.

189

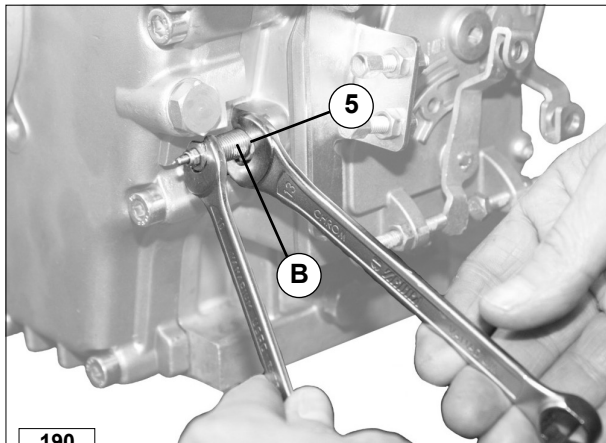

Injection pump delivery approximate setting

This regulation must be carried out by means of a water brake, otherwise the adjustment will be approximate. proceed in the following way.

Loosen flow rate limiter **B** by 5 turns.

Accelerate the engine to no-load top rate, i.e. to 3800 rpm.

Re-tighten limiter **B** until the engine tends to decelerate.

Loosen limiter **B** by one and a half turns.

Tighten the check nut **5**.

Note: tighten **B** to a 1/4 of full turn if the engine produces an excessive amount of exhaust in the maximum load condition; loosen **B** of a 1/4 of a full turn if no smoke is exhausted and if the engine is unable to develop its maximum power.

190

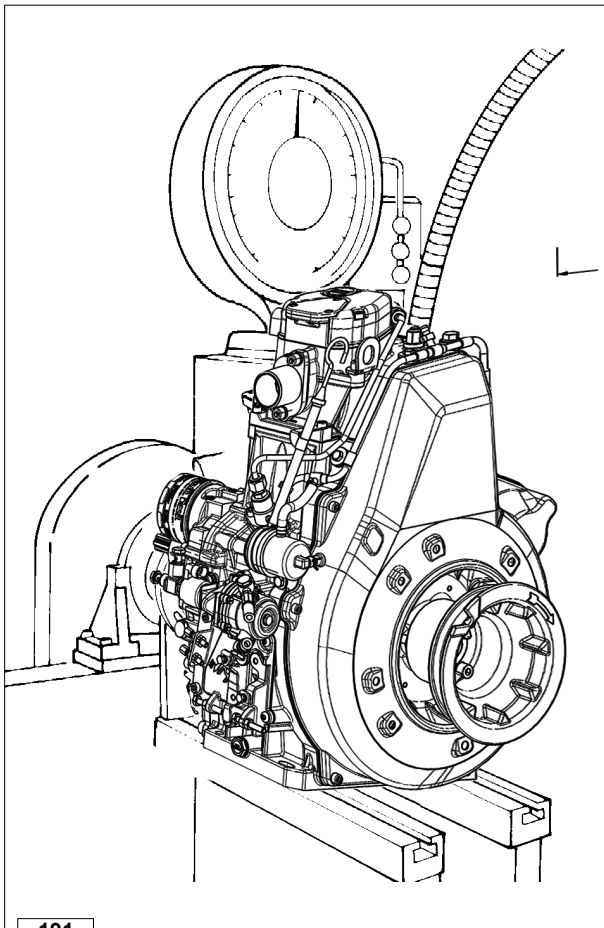

191

Injection pump delivery setting for engines with dynamometric brake

- 1 - Start engine to idling speed
- 2 - Unscrew delivery limiting device **C** (see fig.187)
- 3 - Accelerate the engine and load the dynamometric brake until obtaining power at the rpm required by the application manufacturer.
- 4 - Check that fuel consumption falls within the table specifications (see below).
If consumption is not as indicated change balance conditions at the torque dynamometer by varying the load and adjusting the governor. Under stable engine conditions check consumption again.
- 5 - Tighten limiting device **C** until the engine rpm slightly decreases. Lock the limiting device by means of lock nut.
- 6 - Completely release the brake and check the idle speed at which the engine settles.
Speed governor should comply with the requirements of the class indicated by the manufacturer of the device.
- 7 - Engine running at idle speed. Set the idle speed with warm engine
- 8 - Check valve clearance when engine has cooled down.
- 9 - Stop the engine.

Required settings (the most common ones)

R.P.M.	Power kW	Specific fuel consumption	
		Time (sec) pour 100 cc	g/kW.h
3600	6.8	162	273

ENGINE STORAGE

- **When the engines are not in use for more than 6 months, they have to be protected performing the operations described in the following pages.**
- If the engine is not to be used for extensive periods, check the storage area conditions and the type of packaging and make sure that these are suitable for correct storage.
If necessary, cover the engine with a proper protective sheet.
- Avoid storing the engine in direct contact with the ground, in environments that are humid and exposed to bad weather, near high voltage electric lines, etc.

**Important**

If, after the first 6 months, the engine is still not used, it is necessary to carry out a further measure to extend the protection period (see "Protective treatment").

PROTECTIVE TREATMENT

- 1 - Pour in the engine housing AGIP RUSTIA C protective oil up to the maximum level.
- 2 - Fill up with fuel containing 10% AGIP RUSTIA NT.
- 3 - Start the engine and keep it idle at minimum speed for some minutes.
- 4 - Bring the engine to $\frac{3}{4}$ of the maximum speed for 5÷10 minutes.
- 5 - Turn off the engine.
- 6 - Empty out completely the fuel tank.
- 7 - Spray SAE 10W on the exhaust and intake manifolds.
- 8 - Seal the exhaust and intake ducts to prevent foreign bodies from entering.
- 9 - Thoroughly clean all external parts of the engine using suitable products.
- 10 - Treat non-painted parts with protective products (AGIP RUSTIA NT).
- 11 - Cover the engine with a proper protective sheet.

**Caution - Warning**

In countries in which AGIP products are not available, find an equivalent product (with specifications: MIL-L-21260C).

**Important**

Maximum every 24 months of inactivity, the engine must be started up by repeating all "Engine Storage" operations.

PREPARING THE ENGINE FOR OPERATION AFTER PROTECTIVE TREATMENT

After the storage period and before starting up the engine and preparing it for operation, you need to perform certain operations to ensure maximal efficiency conditions.

- 1 - Remove the protective sheet.
- 2 - Remove any sealing devices from the exhaust and intake ducts.
- 3 - Use a cloth soaked in degreasing product to remove the protective treatment from the external parts.
- 5 - Inject lubricating oil (not more than 2 cm³) into the intake ducts.
- 6 - Turn the engine manually to check the correct movement and smoothness of the mechanical parts.
- 7 - Refill the tank with fresh fuel.
- 8 - Make sure that the oil is up to the maximum level.
- 9 - Start the engine and after some minutes bring it to $\frac{3}{4}$ of the maximum speed for 5÷10 minutes.
- 10 - Turn off the engine.
- 11 - Remove the oil drain plug (see "Oil replacement") and discharge the AGIP RUSTIA NT protective oil while the engine is hot.
- 12 - Pour new oil (see "Table of lubricants") up to the maximum level.
- 13 - Replace the filters (air, oil, fuel) with original spare parts.

**Caution - Warning**

Over time, a number of engine components and lubricants lose their properties, so it is important considering whether they need replacing, also based on age (see Replacement table).

**Important**

Maximum every 24 months of inactivity, the engine must be started up by repeating all "Engine Storage" operations.

MAIN TORQUE SPECIFICATIONS		
POSITION	Diam. and pitch (mm)	Torque (Nm)
Re-coil starting	6x1	10
Connecting rod	8x1	35
Rocker arm adjusting screw lock nut	6x0.5	7
Rocker arm adjusting screw pin	8x1.25	20
Shroud	6x1	10
Rocker arm cover	6x1	10
Control arm cover	6x1	7
Bottom cap	6x1	10
Exhaust manifold	8x1.25	25
Air cleaner support	8x1.25	25
Injection tappet guide screw	6x1	9
Injector fixing onto the head	6x1	12
Fuel pump	8x1.25	15
Injection pump union	14x1.5	40
Injection pump fastening screws	6x1	16
Oil pump support	6x1	10
Gear cover, timing side	8x1.25	23
Injection pump delivery union	14x1.5	40
Fuel tank top fixing	14x1.5	20
Oil drain plug	-	-
Cylinder head (*)	6x1	6
Flywheel pulley fixing screws	8x1.25	25
Flywheel	14x1.5 left	150

USE OF SEALANT	
POSITION	TYPE OF SEALANT
Air valve case	Loctite 596 or 209079
M6 fixing screw for fuel filter	Loctite 243
M6 fixing screws for air shroud	Loctite 243
M6 screw for injection tappet guide	Loctite 270
M8 STEI screw for closing oil intake hole cover	Loctite 270
M8 fixing screws for air filter support and intake manifold	Loctite 270
Rocker arm fulcrum screws	Loctite 270
Stator screws	Loctite 270
Base coupling surface - cover	Loctite 5205
Tappet contact - cam	MOLYSLIP AS COMPOUND 40

Table of tightening torques for standard screws (coarse thread)

















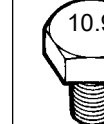





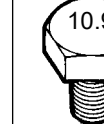
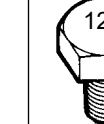
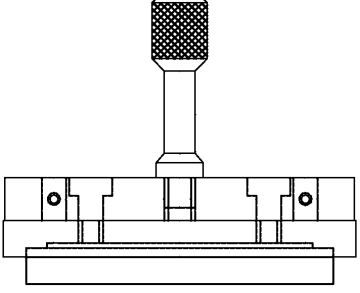
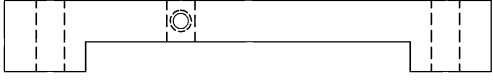
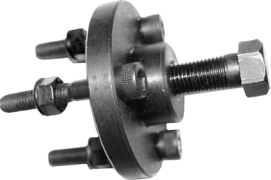

Resistance class (R)								
Quality/ Dimensions								
Diameter	R>400N/mm ²		R>500N/mm ²		R>600N/mm ²	R>800N/mm ²	R>1000N/mm ²	R>1200N/mm ²
	Nm	Nm	Nm	Nm	Nm	Nm	Nm	Nm
M3	0.5	0.7	0.6	0.9	1	1.4	1.9	2.3
M4	1.1	1.5	1.4	1.8	2.2	2.9	4.1	4.9
M5	2.3	3	2.8	3.8	4.5	6	8.5	10
M6	3.8	5	4.7	6.3	7.5	10	14	17
M8	9.4	13	12	16	19	25	35	41
M10	18	25	23	31	37	49	69	83
M12	32	43	40	54	65	86	120	145
M14	51	68	63	84	101	135	190	230
M16	79	105	98	131	158	210	295	355
M18	109	145	135	181	218	290	405	485
M20	154	205	193	256	308	410	580	690
M22	206	275	260	344	413	550	780	930
M24	266	355	333	444	533	710	1000	1200
M27	394	525	500	656	788	1050	1500	1800
M30	544	725	680	906	1088	1450	2000	2400

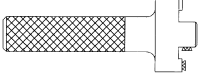
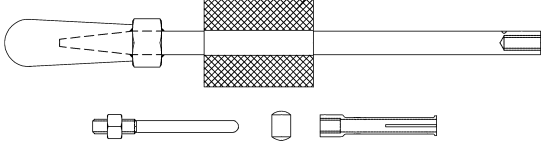
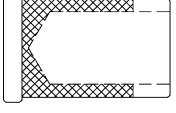
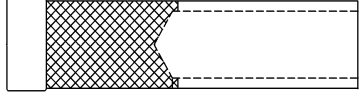
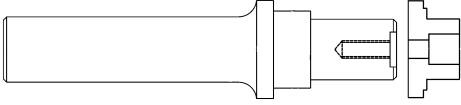
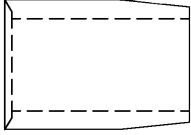
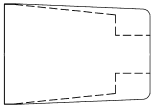
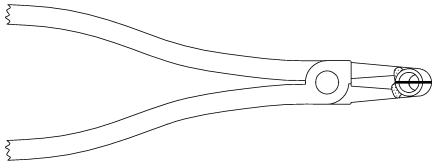
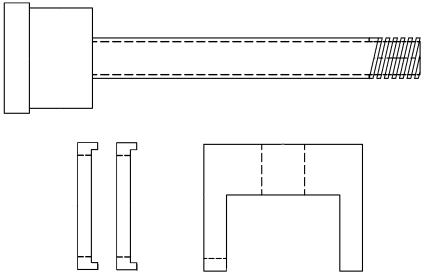
Table of tightening torques for standard screws (fine thread)

Resistance class (R)								
Quality/ Dimensions								
Diameter	R>400N/mm ²		R>500N/mm ²		R>600N/mm ²	R>800N/mm ²	R>1000N/mm ²	R>1200N/mm ²
	Nm	Nm	Nm	Nm	Nm	Nm	Nm	Nm
M 8x1	10	14	13	17	20	27	38	45
M 10x1	21	28	26	35	42	56	79	95
M 10x1.25	20	26	24	33	39	52	73	88
M 12x1.25	36	48	45	59	71	95	135	160
M 12x1.5	38	45	42	56	68	90	125	150
M 14x1.5	56	75	70	94	113	150	210	250
M 16x1.5	84	113	105	141	169	225	315	380
M 18x1.5	122	163	153	203	244	325	460	550
M 18x2	117	157	147	196	235	313	440	530
M 20x1.5	173	230	213	288	345	460	640	770
M 20x2	164	218	204	273	327	436	615	740
M 22x1.5	229	305	287	381	458	610	860	1050
M 24x2	293	390	367	488	585	780	1100	1300
M 27x2	431	575	533	719	863	1150	1600	1950
M 30x2	600	800	750	1000	1200	1600	2250	2700

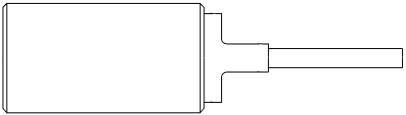
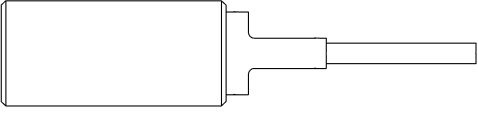
SPECIAL TOOLS	DESCRIPTION	Part N°.
	Gasket selection tool	1460-343
	Timing tool	1460-344
	Flywheel puller	1460-120
	Flywheel clamping tool	1460-330
	Bancer shaft bearing pressing tool	1460-327
	Bancer shaft bearing extractor tool	1460-345
	Oil seal pressing tool flywheel side	1460-328
	Oil seal pressing tool PTO side	1460-346
	Roller bearing assembly/disassembly and PTO side oil seal pressing tool	1460-347
	Oil seal protection tool PTO side	1460-329

SPECIAL TOOLS	DESCRIPTION	Part N°.
	Oil seal protection tool flywheel side	1460-331
	Fuel pipe assembly tool	1460-023
	Assembly/extraction tool for timing cover side bearing and for crankcase side bearing	1460-333
	Tool for valve stem O-ring assembly	1460 - 047
	Tool for valve cotters assembly/disassembly	1460 - 113
	Valve guide removal tool	1460-337
	Valve guide/valve seat pressing tool - intake valve	1460-338
	Valve guide/valve seat pressing tool - exhaust valve	1460-339
	Nylon bars	1460-332
	Threaded bars for connecting rod caps	1460-340
	Assembly tool for min/max governor	1460-341
	Assembly tool for min/max governor	1460-342



Contacts: <https://www.engines.rehko.com/contact>
Parts Catalogue: [Global Parts Lookup](#)