

KDI-TCP 3404E5

OWNER MANUAL



 **rehlko**

REGISTRATION OF MODIFICATIONS TO THE DOCUMENT

Any modifications to this document must be registered by the drafting body, by completing the following table.

Released by	Document code	Revision	Issue date	Review date	Edited by	Endorsed
Technical Documentation	ED0053033030-S	01.6	06/2017	05/2026	C. Accoti	SERVICE DEPT.

Translated from the original manual in Italian language.

Data reported in this issue can be modified at any time by **REHLKO**.



Important

The latest version of this manual is available on the i-Service website, connect to the following link <https://iservice.lombardini.it>, before downloading the manual, you can select the desired language from the top bar of the site as shown in the figure below.



The screenshot shows the top navigation bar of the website. On the left, there is the 'rehlko | iService' logo and the text 'Area riservata' and 'Logout'. On the right, there is a language selection dropdown menu with the following options: ITALIANO (selected), ENGLISH, DEUTSCH, ESPAÑOL, FRANÇAIS, and 富盈. The dropdown menu is highlighted with a red border.

1	General Information	6
1.1	<i>Manual's Purpose</i>	6
1.2	<i>Glossary and Definitions</i>	6
1.3	<i>Emission-Related Installation Instructions</i>	7
1.4	<i>Service request.....</i>	7
1.5	<i>Manufacturer and engine identification</i>	8
1.6	<i>Engine component identification</i>	9
1.7	<i>Cooling circuit</i>	11
1.8	<i>DEF circuit</i>	13
1.9	<i>Intake and exhaust circuit.....</i>	14
1.10	<i>Homologation labels</i>	16
1.11	<i>ATS (After Treatment System).....</i>	18
2	Technical information	19
2.1	<i>General description of the engine.....</i>	19
2.2	<i>Engine specifications</i>	19
2.3	<i>Oil.....</i>	20
2.4	<i>Fuel.....</i>	22
2.5	<i>DEF.....</i>	23
2.6	<i>Coolant recommendation.....</i>	25
2.7	<i>Battery recommendation</i>	25
2.8	<i>Inducement strategy of ATS system.....</i>	26
2.9	<i>Control panel</i>	28
3	Safety information	29
3.1	<i>Safety information.....</i>	29
3.2	<i>General remarks.....</i>	29
3.3	<i>Safety signal description</i>	32
3.4	<i>Information and safety signals</i>	33
3.5	<i>Safety and environmental impact</i>	35
4	Information about use	36
4.1	<i>Pre-start check.....</i>	36
4.2	<i>Running-in period</i>	36
4.3	<i>Starting and turning off.....</i>	36
4.4	<i>Refuelling.....</i>	37
4.5	<i>Oil filling</i>	38
4.6	<i>Coolant filling.....</i>	39
4.7	<i>DEF filling.....</i>	40

4.8	<i>Inducement SCR</i>	40
4.9	<i>ATS regeneration strategy</i>	41
5	Information about maintenance	43
5.1	<i>Useful information about maintenance</i>	43
5.2	<i>Periodic maintenance</i>	43
5.3	<i>Oil level check</i>	45
5.4	<i>Air filter check</i>	46
5.5	<i>Check of the radiator heat - exchanger surface</i>	46
5.6	<i>Rubber hoses check</i>	47
5.7	<i>Check coolant level</i>	48
5.8	<i>Filter cartridge and fuel pre-filter check</i>	48
5.9	<i>Product preservation</i>	49
5.10	<i>Engine storage up to 6 months</i>	49
5.11	<i>Engine storage over 6 months</i>	49
5.12	<i>Engine starting after storage</i>	50
5.13	<i>Unused machine</i>	50
6	Information about replacements	52
6.1	<i>Engine oil replacement</i>	52
6.2	<i>Oil filter cartridge replacement</i>	53
6.3	<i>Filter cartridge and fuel pre-filter replacement</i>	54
6.4	<i>Air filter cartridge replacement</i>	55
6.5	<i>Replacement of DEF filter</i>	56
6.6	<i>Disposal and scrapping</i>	56
7	Information about failures	57
7.1	<i>Useful information about failures</i>	57
8	Information about warranty	59
8.1	<i>Warranty terms</i>	59
9	Glossary	60
9.1	<i>Glossary</i>	60

1 GENERAL INFORMATION

1.1 *Manual's Purpose*

- This manual contains the instructions needed to carry out proper use and maintenance of the engine, therefore it must always be available, for future reference when required.
- This manual is an integral part of the engine, in the event of transfer or sale, it must be attached to it.
- Safety pictograms can be found on the engine and it is the operator's responsibility to keep them in a perfectly visible place and replace them when they are no longer legible.
- Information, description and pictures in this manual reflect the state of the art at the time of the marketing of engine.
- However, development on the engines is continuous. Therefore, the information within this manual is subject to change without notice and without obligation.
- **REHLKO** reserves the right to make, at any time, changes in the engines for technical or commercial reasons.
- These changes do not require **REHLKO** to intervene on the marketed production up to that time and not to consider this manual as inappropriate.
- Any additional section that **REHLKO** will deem necessary to supply some time after the main text shall be kept together with the manual and considered as an integral part of it.
- The information contained within this manual is the sole property of **REHLKO** . As such, no reproduction or replication in whole or part is allowed without the express written permission of **REHLKO** .

1.2 *Glossary and Definitions*

The paragraphs, tables and figure are divided into chapter with their progressive numbers.

Es: **Par. 2.3** - chapter 2 paragraph 3.

Tab. 3.4 - chapter 3 table 4.

The references of the objects described in the text and in figure and number are indicated by letters, which are always and only related to the paragraph you are reading unless there are specific references to other figures or paragraphs.

NOTE: All data, measurements and relevant symbols are shown in the glossary section.

1.3 Emission-Related Installation Instructions

Failing to follow the instructions in the applications guidebook when installing a certified engine in a piece of nonroad equipment violates federal law (40 CFR 1068.105(b)), subject to fines or other penalties as described in the Clean Air Act. OEM must apply a separate label with the following statement: “ULTRA LOW SULFUR FUEL ONLY” near the fuel inlet.

Ensure you are installing an engine appropriately certified for your application. Constant speed engines may only be installed on constant speed equipment for constant speed operation.

If you install the engine in a way that makes the engine's emission control information label hard to read during normal engine maintenance, you must place a duplicate label on the equipment, as described in 40 CFR 1068.105.

1.4 Service request

- The complete and updated list of authorized **Rehko** service centers can be found on websites: <https://www.engines.rehko.com/> & <https://www.engines.rehko.com/dealers> .
- If you have any questions regarding your warranty rights and responsibilities or the location of the nearest **Rehko** authorized service location, you should contact **Rehko** at 1-800-544-2444 or access our website at <https://www.engines.rehko.com/> (USA and North American).

1.5 Manufacturer and engine identification

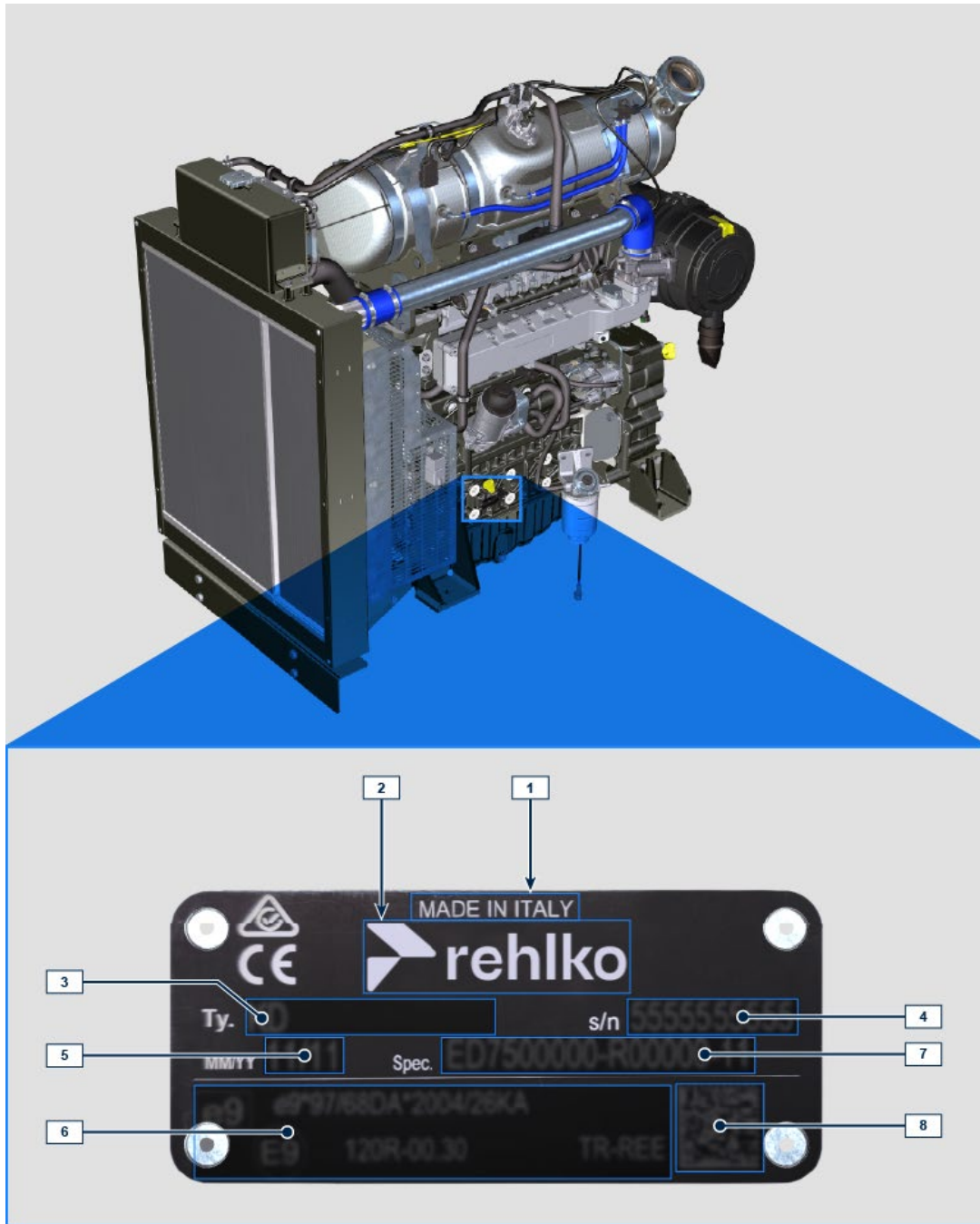

1.1

Pos.	Description
1	Production place
2	Manufacturer identification
3	Engine model
4	Engine serial number
5	Month and year of production
6	Approval data
7	Engine version
8	Data matrix

1.6 Engine component identification

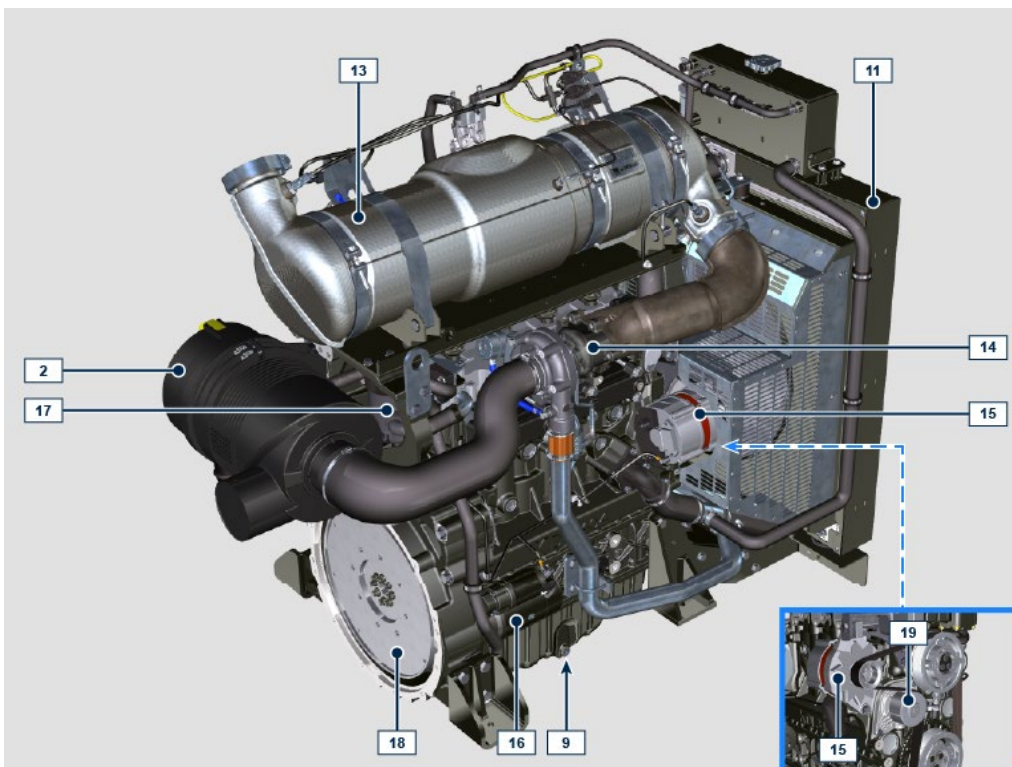
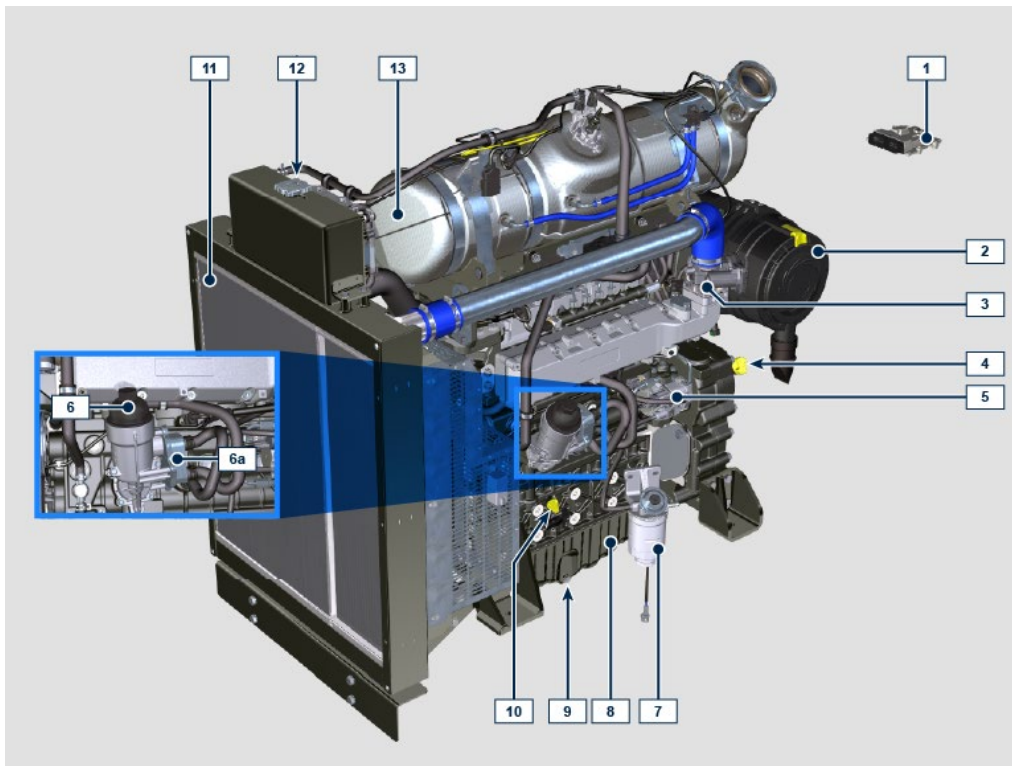

NOTE: Some components are for illustrative purposes only and may vary or they are not supplied by REHLKO.

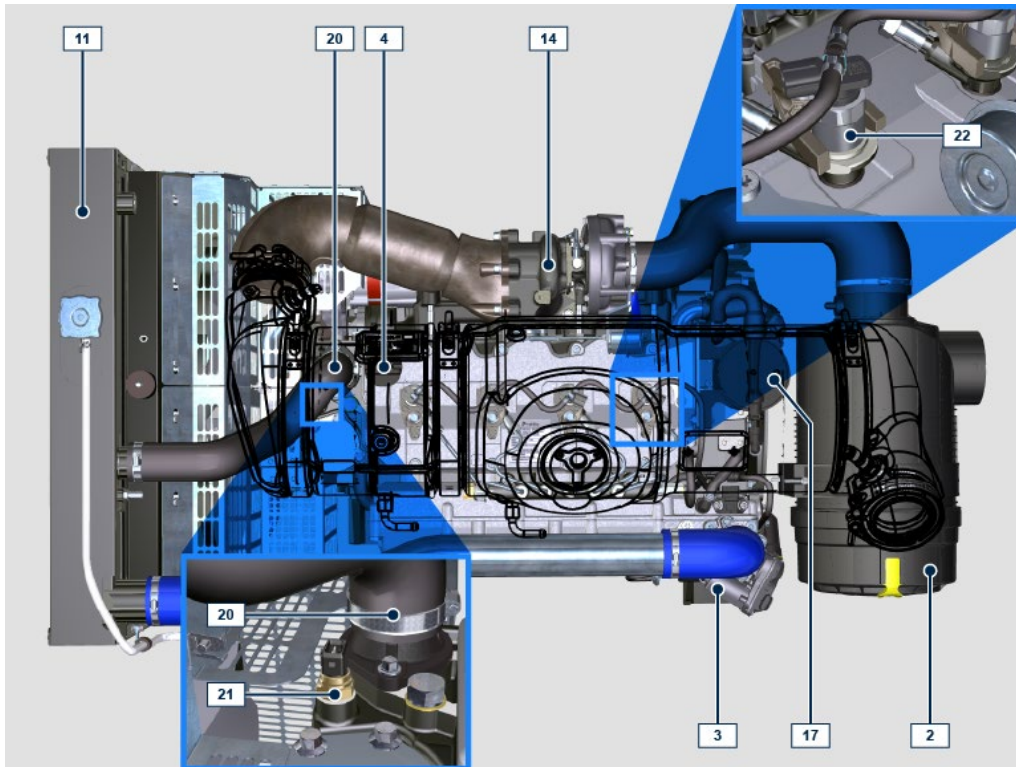

POS.	DESCRIPTION
1	ECU
2	Air filter
3	ETB
4	Oil filler cap
5	High-pressure fuel injection pump
6	Lub. oil filter
6a	Oil cooler
7	Fuel filter
8	Oil sump
9	Oil drain plug
10	Oil dipstick
11	Radiator/Intercooler
12	Coolant filler cap
13	ATS
14	Turbocharger
15	Alternator
16	Starter motor
17	Oil steam separator
18	Flywheel
19	Coolant pump
20	Thermostatic valve
21	Coolant temperature sensor
22	Electronic injector

1.7 Cooling circuit

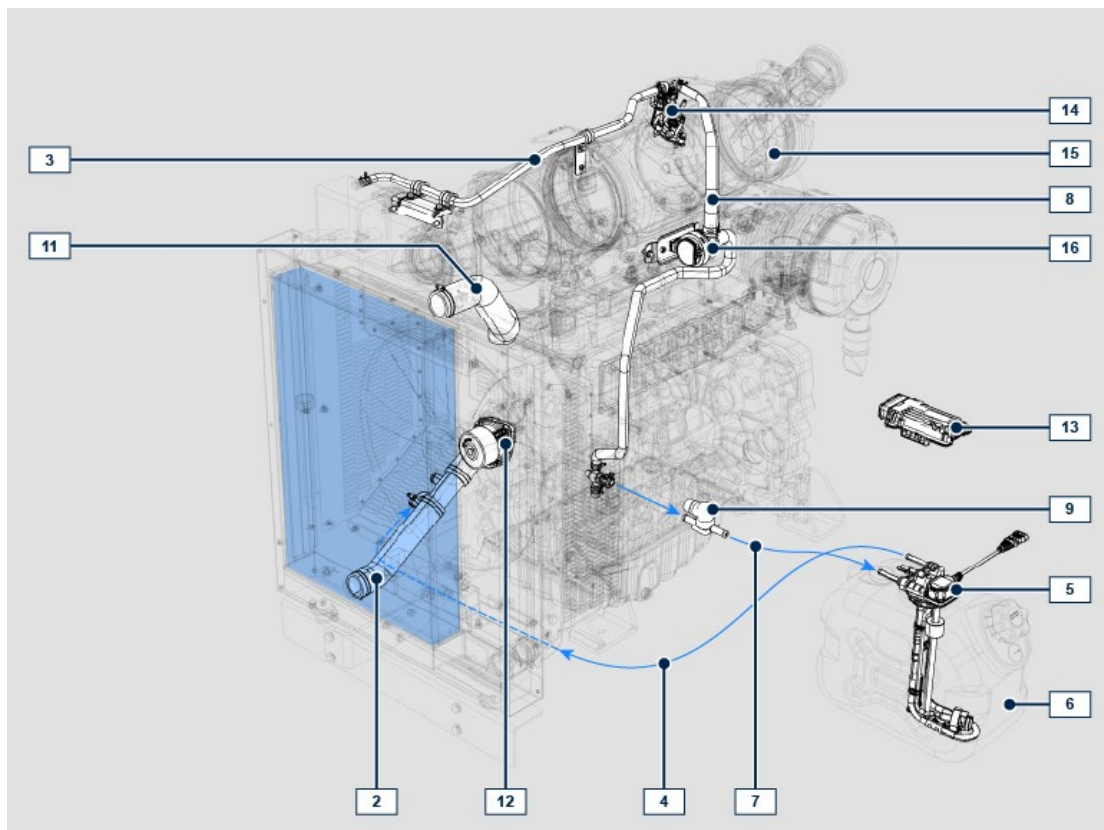
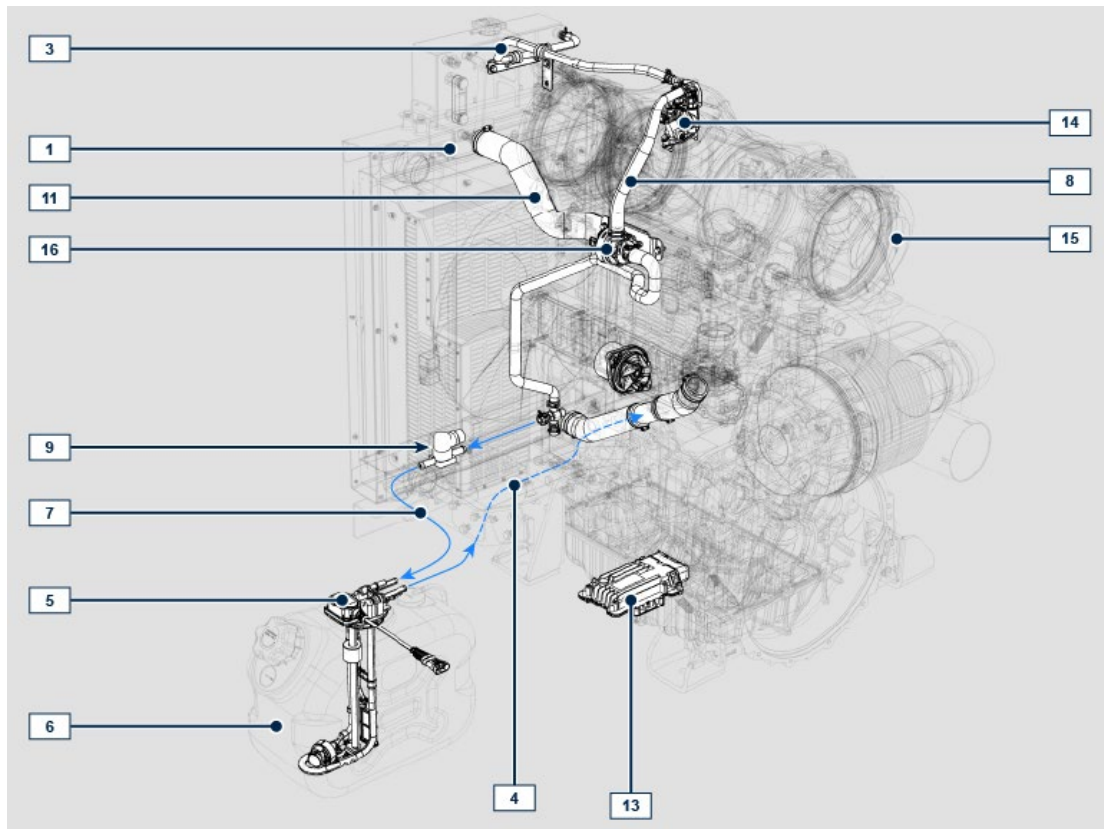

NOTE: Some components are for illustrative purposes only and may vary or they are not supplied by REHLKO.

POS.	DESCRIPTION
1	Radiator
2	Intake sleeve
3	Return tube to radiator
4	Intake return tube
5	Circuit for DEF heating
6	DEF tank
7	Coolant delivery tube in DEF tank
8	Coolant delivery tube to DEF injector
9	Solenoid valve
10	Refrigerant delivery pipe to DEF heating solenoid valve
11	Coolant to radiator return sleeve
12	Coolant pump
13	DEF Dosing Control Unit (DCU)
14	DEF Injector
15	ATS
16	Coolant delivery pump to DEF injector (provided if needed)

1.8 DEF circuit

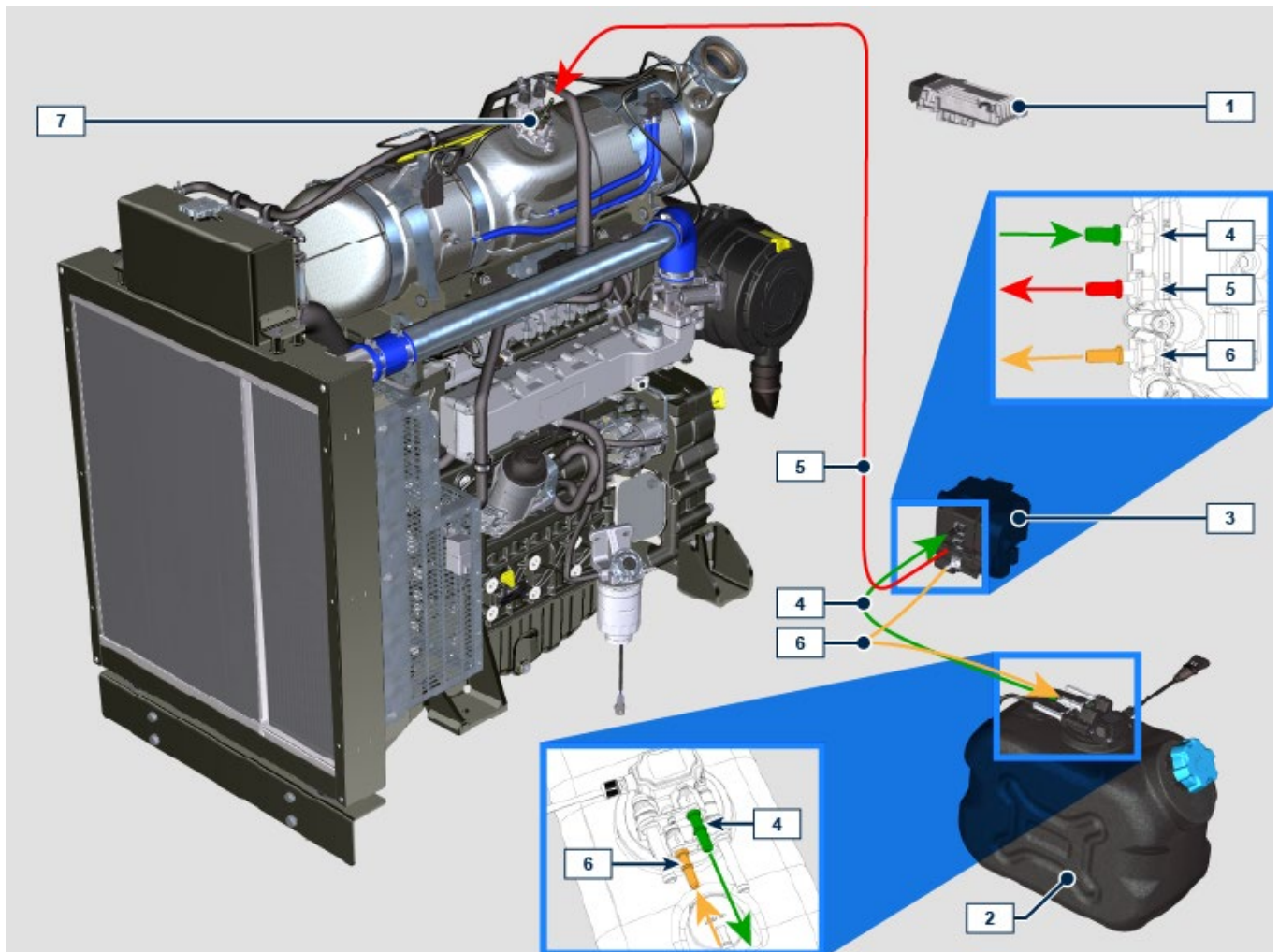

NOTE: Some components are for illustrative purposes only and may vary or they are not supplied by REHLKO .

POS.	DESCRIPTION
1	DEF Dosing Control Unit (DCU)
2	DEF tank
3	DEF pump
4	DEF intake tube
5	DEF delivery tube to injector
6	Return tube in DEF tank
7	DEF injector

1.9 Intake and exhaust circuit

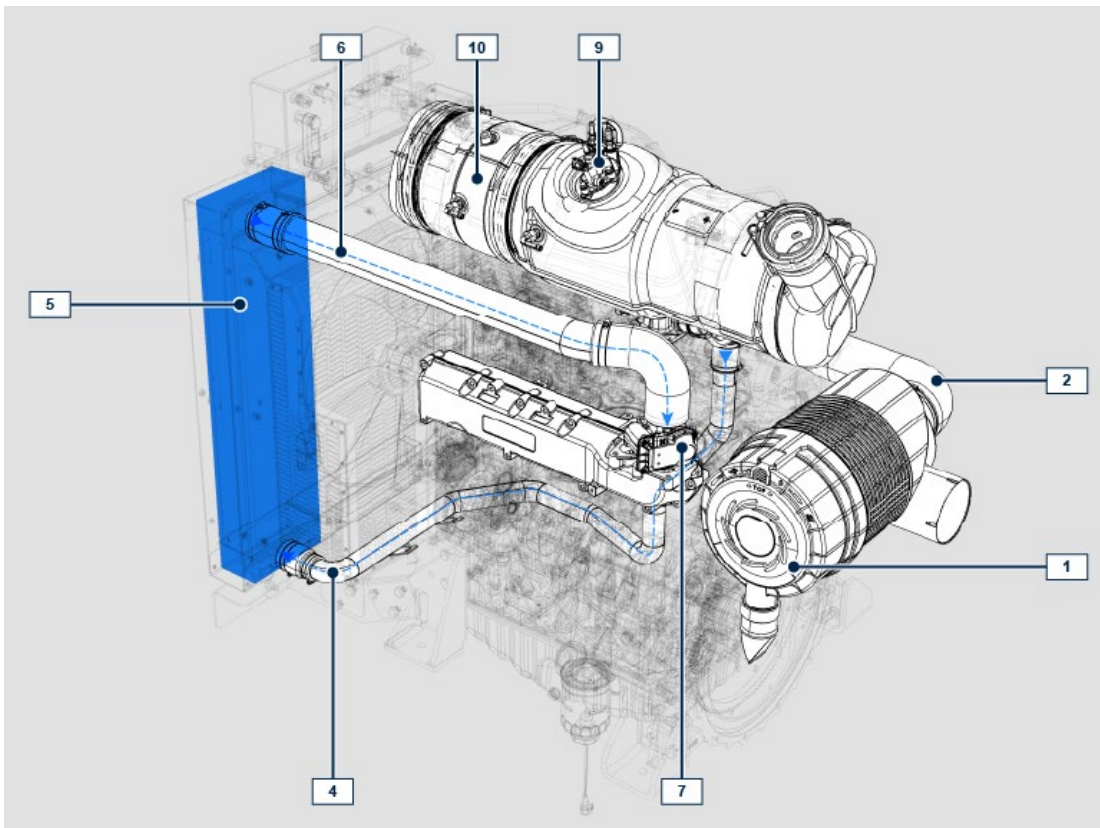
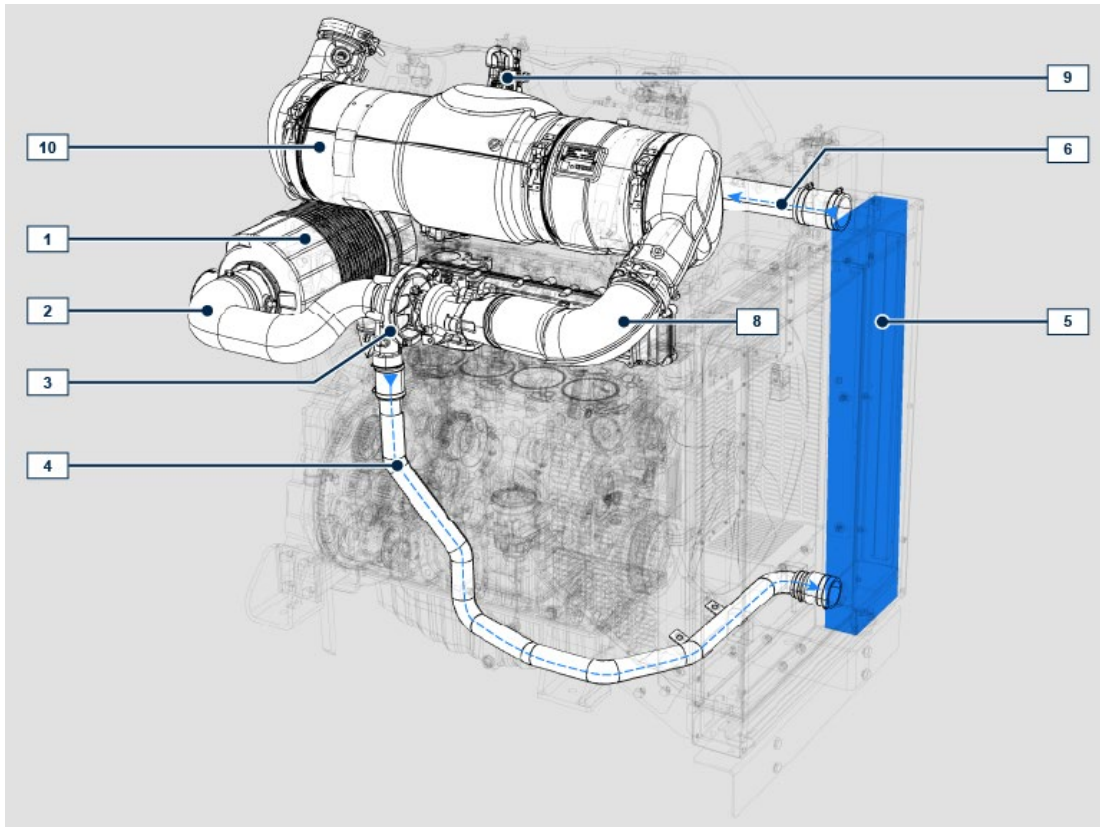

NOTE: Some components are for illustrative purposes only and may vary or they are not supplied by REHLKO .

POS.	DESCRIPTION
1	Air filter
2	Air intake sleeve
3	Turbocharger
4	Air delivery tube to Intercooler
5	Intercooler
6	Air delivery tube to intake manifold
7	ETB
8	Exhaust gas delivery hose to ATS
9	DEF injector
10	ATS

1.10 Homologation labels

1.10.1 Label for EPA rules (compilation example)

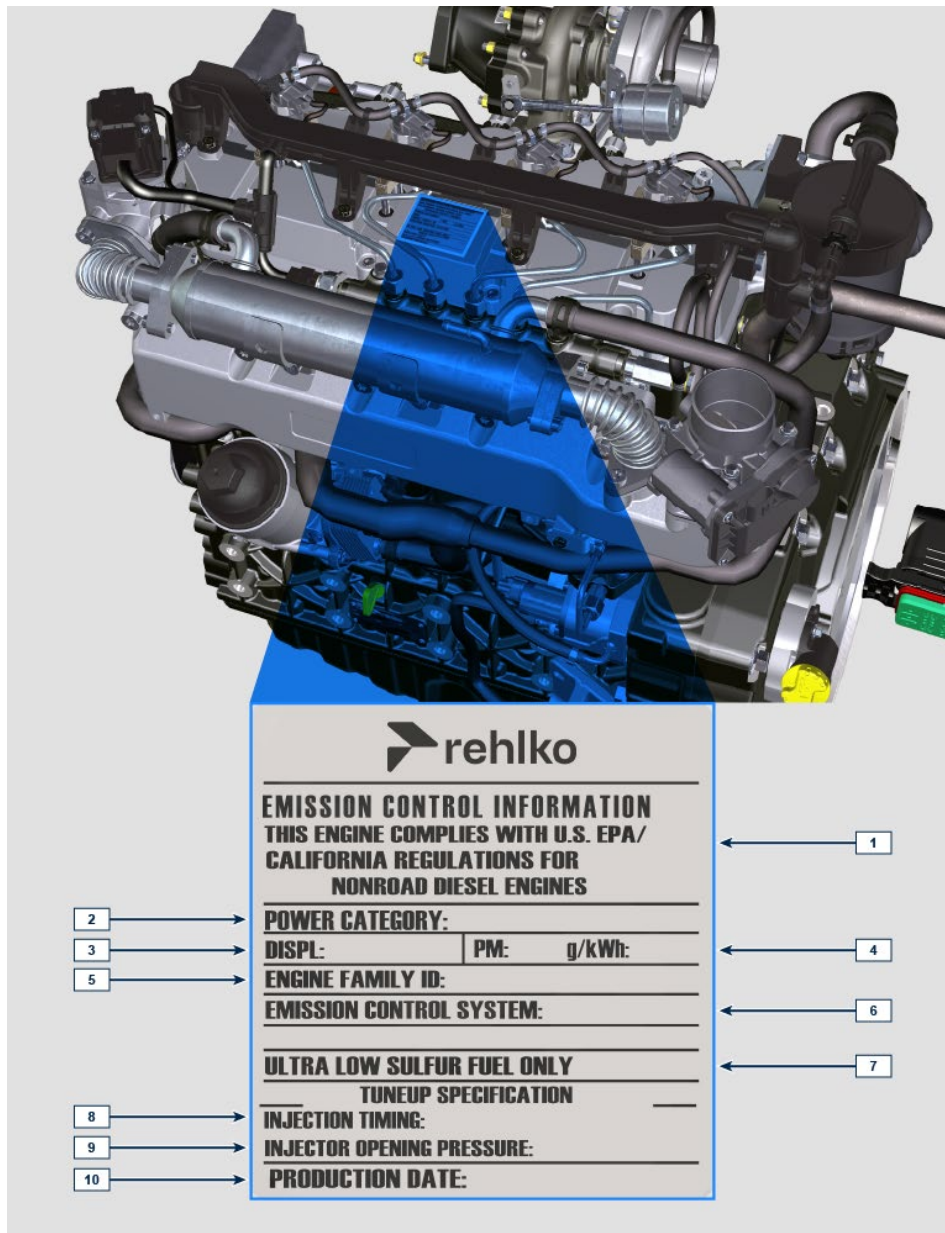

POS.	DESCRIPTION
1	Model year in compliance with the rules
2	Power category (kW)
3	Engine displacement (L)
4	Particulate emission limit (g/kWh)
5	Engine family ID
6	Emission Control System = ECS
7	Fuel with low sulphur content
8	Injection timing
9	Electronic injector opening pressure (bar)
10	Production date (example: 2013.JAN)

1.10.2 Label for China Standards (compilation example)



POS.	DESCRIPTION
1	Manufacturer
2	Engine model
3	Manufacturing date
4	Certificate N°
5	Power range (kW)
6	Emission level
7	Rated power
8	Aftertreat system

1.10.3 Label for Korea Standards (compilation example)



POS.	DESCRIPTION
1	Tier 4 Final
2	Engine model
3	Manufacturing date and manufacturer code
4	N° Korea emission certificate

1.11 ATS (After Treatment System)

ATS with DOC+DPF+SCR filter

NOTE: the ATS system with DPF filter is only present for versions compliant with "Stage V" emission regulations.
The ATS system can be installed in a different way than shown.

1.5

POS.	DESCRIZIONE
1	Turbocharger
2	Turbine exhaust pipe
3	DOC
4	DPF
5	SCR
6	ETB

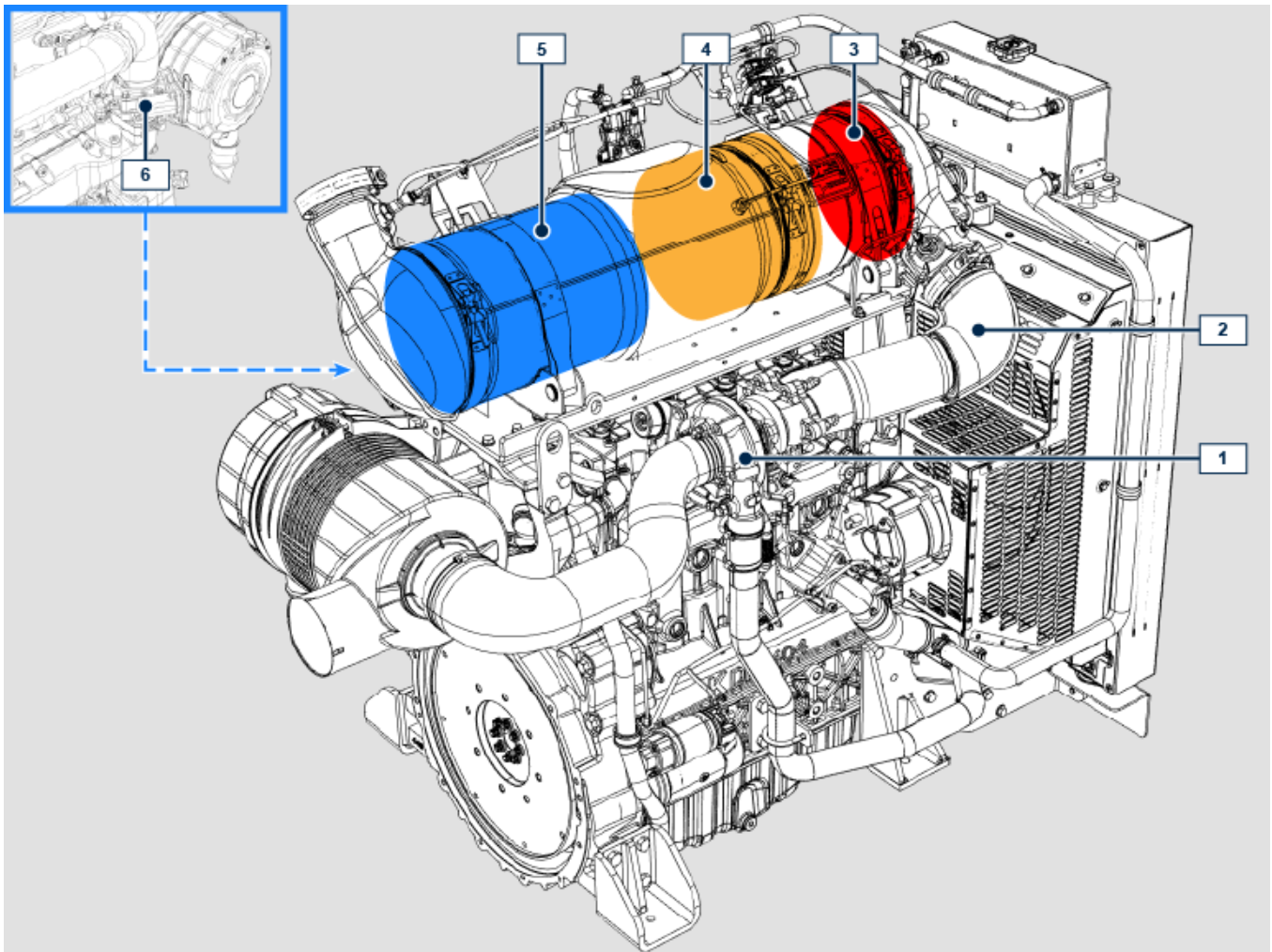

2 TECHNICAL INFORMATION

2.1 General description of the engine

- 4-stroke, in-line cylinders Diesel engine; - Liquid-cooling system;
- 4 valves per cylinder with hydraulic tappets;
- Turbocharger with Waste-gate valve;
- Common rail - Direct injection.

2.2 Engine specifications

2.1

TECHNICAL DATA		UNIT OF MEASURE	
Engine type			KDI-TCP 3404 E5
Cylinders		n.	4
Bore		mm	96
Stroke		mm	116
Displacement		cm ³	3359
MAX INCLINATION DURING OPERATION (even in combined)		α	40° max 30 min.
		α	45° max 1 min.
OIL CAPACITY (MAX level.) including oil filter		standard version	lt.
DRY WEIGHT			Kg

2.3 Oil

**Important**

- The engine may be damaged if operated with improper oil level.
- Do not exceed the **MAX** level because a sudden increase in engine rpm could be caused by its combustion.
- Use only the recommended oil to ensure adequate protection, efficiency and service life of the engine.
- The use of lubricants other than recommended may shorten the engine life.
- Viscosity must be appropriate to the ambient temperature to which the engine is to be exposed.

**Danger**

- Prolonged skin contact with the exhausted engine oil can cause cancer of the skin.
- If contact with oil cannot be avoided, thoroughly wash your hands with soap and water as soon as possible.
- For the exhausted oil disposal, refer to the **Par. DISPOSAL and SCRAPPING**.

2.4.1 SAE oil classification

- In the SAE classification, oils are identified according to viscosity without considering any other qualitative characteristic.
- The code is composed of two numbers, which indicate, and must correspond to, the ambient temperature in which the engine operates, the first number refers to the viscosity when cold, for use during winter (" **W** "), while the second number is for viscosity at high temperatures.

Use oil viscosity based on the experienced air temperature range during the period between oil changes as indicated in the table below.

Rehiko X-treme 10W-40 formula pro; X-treme 10W-40; X-treme 5W-40 oil are preferred:



Oils meeting the following specifications are also recommended.

2.2

RECCOMENDED OIL				
		TCR STAGE-V (*1) (*2)	TCR TIER IV FINAL (*1)	TCR/D TIER III o NON CERTIFICATO (*3)
WITH SPECIFICATIONS	API	CJ-4 Low S.A.P.S CK-4 Low S.A.P.S	CJ-4 Low S.A.P.S CK-4 Low S.A.P.S	CI-4 Plus CI-4 CH-4
	ACEA	E6 Low S.A.P.S.	E6 Low S.A.P.S.	E7 E4
VISCOSITY	SAE	0w-40 (-40°C ÷ +50°C) 5w-40 (-30°C ÷ +50°C) 10w-40 (-25°C ÷ +50°C)	0w-40 (-40°C ÷ +50°C) 5w-40 (-30°C ÷ +50°C) 10w-40 (-25°C ÷ +50°C)	0w-40 (-40°C ÷ +50°C) 5w-40 (-30°C ÷ +50°C) 10w-40 (-25°C ÷ +50°C)

- Low S.A.P.S. technology (oil with low Sulfated Ash, Phosphorus, Sulfur content) keeps catalyst in good working conditions. The presence of sulfated ash, phosphorus and sulfur causes with time the catalyst clogging and its consequent inefficiency.
- For Mid S.A.P.S oil sequence the sulfated ash level is the same as API CJ-4 $\leq 1.0\%$ but as per ACEA standardization those oils are referenced as mid SAPS.
- Filtration of oils is critical to proper operation and lubrication; always change filters regularly as specified in this manual.

(*1) NOTE : Do NOT use fuel with sulphur content above 15ppm.

(*2) - On all engines compliant with Stage-V emission regulation (engines with DPF device), the oil to use must comply with the specification API CJ-4 Low S.A.P.S or ACEA E6 Low S.A.P.S.

(*3) - NOTE : Do NOT use fuel with sulphur content above 500ppm.

(*3) - NOTE : Low S.A.P.S. oils, sulfate ashes $<1\%$ may not be used with fuels with a sulfur content $>50\text{ppm}$.

2.4 Fuel

**Important**

- Use of other types of fuel could damage the engine. Do not use dirty diesel fuel or mixtures of diesel fuel and water since this will cause serious engine faults.

**Warning**

- Clean fuel prevents the fuel injectors from clogging. Immediately clean up any spillage during refuelling.
- Never store diesel fuel in galvanized containers (i.e. coated with zinc). Diesel fuel and the galvanized coating react chemically to each other, producing flaking that quickly clogs filters or causes fuel pump and/or injector failure.
- Any failure resulting from the use of fuel other than **Tab. 2.3** will not be covered by warranty.

Cetane number of 40 minimum. Cetane number greater than 47 is preferred, especially for temperatures below $-20\text{ }^{\circ}\text{C}$ ($-4\text{ }^{\circ}\text{F}$) or elevations above 1675 m (5500 ft.).

Highly Regulated Engines (EU, USA, CANADA, JAPAN, CHINA, INDIA)

- EU EN 590
- North America ASTM D975 No. 2-D S15; No. 1-D S15
- Japan JIS K 2204 No. 1; No. 2
- India BS-V ULSD; BS-VI ULSD
- China GB 19147-2016 ULSD; GB 17691—2018 ULSD
- HVO EN 15940 or ASTM D975
- Military NATO fuel F-54 S < 10ppm

Less or Not Regulated Engines (Rest of the World and Military applications)

- Equivalent to all above specification
- Equivalent to all above specification but with Sulphur < 500ppm
- Equivalent to all above specification but with Sulphur < 2000ppm
- F-34/F-35 (kerosene NATO designation) **(1)**
- F-44 (kerosene, NATO designation) **(1)**
- F-63 (kerosene, NATO designation, equivalent to F-34/F-35 with additives) (1)
- JP-8 (kerosene, US military designation) **(1)**
- JP-5 (kerosene, US military designation) **(1)**
- Jet A / A1 (kerosene for civil aviation) **(1)**



(1) - Operations with Jet Fuels: The jet fuels can be used but only adopting an additional fuel filter with lubricity doser. Because of lower density and greater leak fuel volume due to lower viscosity, depending on the engine speed and torque, a power loss up to 10% is possible. There are some problematical fuel properties amongst the listed jet fuels (viscosity, lubricating capacities and low boiling point). A slight increase in wear in the injection system is to be expected which can lead to a statistically shorter life of these components. Sulphur content must be below 2000ppm.

2.5.1 Fuel Additives

To aid in maintaining performance of the engines injection system, Rehlko has developed a family of fuel additives product for North America market.

The Extra Performance Fuel Additive Arctic Formula a fuel conditioner in winter, the Extra Performance Fuel Additive a fuel injector deposit removal and prevention. See your local Rehlko dealer for availability.

2.3

<p>Rehlko Extra Performance Fuel Additive (North America only)</p>	
<p>Use Rehlko Injector Cleaner Diesel Fuel Additive before filling the tank once a year or every 500hrs with summer or winter grade fuel. Formulated to clean deposits from injectors and provide lubrication to high pressure pump and injectors to reduce wear, increasing fuel quality. Compatible with all exhaust emission system, including diesel particulate filters (DPFs). Follow all recommended instruction on product label.</p>	
<p>Rehlko Extra Performance Fuel Additive Arctic Formula (North America only)</p>	
<p>Use Rehlko Extra Performance Fuel Additive Arctic Formula, which contains anti-gel chemistry to treat non-winter grad fuel (No. 2-D in North America) during the cold-weather season. This extends the operability to about 10°C (18°F) below the could point. For operability at even lower temperatures, use winter grade fuel. Treat the fuel when the outside temperature drops below 0°C (32°F). For best results, use untreated fuel and follow all recommended instruction on product label. Cloud point is the temperature at which wax begins to form in the fuel causing filters to plug.</p>	
<p>Fuel additives with biocide/algaecide functions are allowed in case of storage of fuel in the tank for long periods (one year or more).</p>	<p>For suggested brands and types contact Rehlko staff</p>
<p>NOTE: These additives must be diluted in the fuel following the product prescribed percentages when filling the tank.</p>	

2.5 DEF

- Also known as "AUS 32" in Europe, "DEF" or "Urea Solution" in the USA, it is registered with the "AdBlue[®]" brand at the Verband der Automobilindustrie (VDA), and must comply with the following ISO standards:
 - ISO 22241-1 Quality requirements
 - ISO 22241-2 Test Methods

- ISO 22241-3 Handling, transportation and Storing
- ISO 22241-4 Refilling Interface
- 2. The DEF tank must be filled by means of the specific automatic filling nozzle at the authorised distributors, refer to the car manual for refilling operations.
- 3. Upon refilling, comply with the MAX level indicated on the tank.
- 4. During the refilling operations prevent any impurity from entering the tank.
- 5. At tank inlet there is a filter that must be periodically cleaned or replaced (see maintenance and replacement table - for tank supplied by **REHLKO** only).
- 6. DEF quality must comply with the specifications described in Table 2.5.



Warning

- Do not mix DEF with fuel or other liquids (including water) and do not fill the fuel tank with DEF.
- The presence of DEF inside the specific tank is required to start the engine.
- Purchase in containers: the container, even if opened, can be stocked with the same conditions of a sealed container.
- Do not stock the container with a temperature higher than 35°C as this could alter the DEF.
- In case of DEF freezing inside the container (< -11,5 °C | 11,3 °F), DEF can be used when it returns to its liquid state.
- Do not expose DEF to direct sunlight.
- In case of opening and closing of the original purchase container, DEF must be checked through a spectrometer to check its quality before use.
- Do not insert altered DEF in the tank as the engine could not respect the emission parameters, generate DCU errors and as a consequence turn off or fail to start the engine.

2.5

PARAMETERS	UNIT OF MEASUREMENT	VALUE
Title	Weight %	31,8 ÷ 33,2
Density at 20°C	kg/m ³	1.087 ÷ 1.093
Refraction index at 20°C	°C	1,3814 ÷ 1,3843
Alkalinity like NH ₃	Weight %	< 0,2
Biuret	Weight %	< 0,3
Aldehyde	mg/kg	< 5
Insoluble	mg/kg	< 20
Phosphates like PO ₄	mg/kg	< 0,5
Calcium	mg/kg	< 0,5
Iron	mg/kg	< 0,5
Copper	mg/kg	< 0,2
Zinc	mg/kg	< 0,2
Chrome	mg/kg	< 0,2
Nickel	mg/kg	< 0,2
Aluminium	mg/kg	< 0,5
Magnesium	mg/kg	< 0,5
Sodium	mg/kg	< 0,5
Potassium	mg/kg	< 0,5
Freezing point	°C	-11

2.6 Coolant recommendation

Rehiko Xtended™ prediluted coolant 50% ethylene glycol OAT is preferred.



Coolant meeting the following specifications are also recommended.

A mixture of 50% demineralized water and 50% low silicate ethylene glycol based coolant liquid must be used. Use a Long Life or Extended Life Heavy Duty OAT coolant free of: silicates, phosphates, borates, nitrites and amines.

The following ethylene-glycol based engine coolant for all models within KSD engine family may be used:

- OAT (Organic Acid Technology) Low Silicate: **ASTM D-3306 D-6210**
- HOAT (Hybrid Organic Acid Technology) Low Silicate: **ASTM D-3306 D-6210**

The above coolants in concentrated formulation must be mixed with distilled, deionized, or demineralized water. A pre-mixed formulation (40-60% or 50-50%) can be used directly when available.

 **Important**

- Do not mix ethylene glycol and propylene glycol based coolants. Do not mix OAT and HOAT based coolant. OAT performance life can be drastically reduced if contaminated with nitrite-containing coolants.
- Never use automotive-type coolants. These coolants do not contain the correct additives to protect heavy – duty diesel engines.

OAT coolants are maintenance free up to 5 years or 4000hrs of operation , provided that the cooling system is topped up using the same type of coolant. Do not mix different coolant types. Test the coolant condition annually with coolant test strips.

HOAT are not all maintenance free and it is recommended to have SCA (Supplemental Coolant Additives) added at the first maintenance interval.

2.7 Battery recommendation

Battery not supplied by REHLKO

2.6

RECOMMENDED BATTERIES				
AMBIENT TEMPERATURE	STARTER MOTOR	OIL	BATTERY TYPE	MACHINE CONDITION
≥ - 25°C	3.2kW + HEATER	10W-40 5W-40	880CCA SAE (=1000 A (EN))	light hydraulic parasitic loads or mechanical clutch and gearbox
≥ - 25°C	4.2kW + HEATER		1000CCA SAE =(1250 A (EN))	heavy hydraulic parasitic loads

2.8 Inducement strategy of ATS system

The inducement is the operation aimed at reducing the engine performance due to a malfunction or tampering with the ATS system detected by the DCU.

The inducement degree is decided by the ECU according to the error detected by the DCU.

The information on the car panel or the activation of the inducement can occur for the following reasons:

- Low DEF level
- Poor DEF quality
- Interruption of DEF supply
- EGR valve malfunctioning
- Tampering with the monitoring systems of the ATS system.

The inducement strategy is applied according to:

- detected problem
- hours passed.

NOTE: Hours are reset after 40h if the DCU does not detect any fault, otherwise the hours are added to those already counted. For low DEF level, activation depends on the percentage of liquid inside the DEF tank, and the fault hours are not counted.

The strategy for the different faults is listed below (Stage V - EU):

The inducement can have the following 2 levels:

- Level 1: 25% reduction of the MAX available torque.
- Level 2: 50% reduction of the MAX available torque and 40% reduction of MAX rpm available.

Before activating the inducement (level 1 or level 2) the ECU activates a warning or a warning light on the car panel (refer to the car documentation for the warning type).

Low DEF level

- information activation on car panel: <10% of MAX level
- Level 1 inducement: <2.5% of MAX level
- Level 2 inducement: 0% of MAX level

Poor DEF quality

- information activation on car panel: upon fault detection
- Level 1 inducement: after 10h from fault detection
- Level 2 inducement: after 20h from fault detection

Interruption of DEF supply

- information activation on car panel: upon fault detection
- Level 1 inducement: after 10h from fault detection
- Level 2 inducement: after 20h from fault detection

EGR valve malfunctioning

- information activation on car panel: upon fault detection
- Level 1 inducement: after 36h from fault detection
- Level 2 inducement: after 100h from fault detection

Tampering with the monitoring systems of the ATS system

- information activation on car panel: upon fault detection
- Level 1 inducement: after 36h from fault detection
- Level 2 inducement: after 100h from fault detection

The strategy for the different faults is listed below (Tier 4 Final - USA):

The inducement can have the following 3 levels:

- Level 1: 25% reduction of the MAX available torque.
- Level 2: 50% reduction of the MAX available torque and 40% reduction of MAX rpm available.
- Level 3: the engine operates at minimum rpm and MAX torque available

Before activating the inducement (level 1, level 2 or level 3) the ECU activates a warning or a warning light on the car panel (refer to the car documentation for the warning type).

Low DEF level

- information activation on car panel: <10% of MAX level
- Level 1 inducement: <5% of MAX level
- Level 2 inducement: <2.5% of MAX level
- Level 3 inducement: <0.5% of MAX level

Poor DEF quality

- information activation on car panel: upon fault detection
- Level 1 inducement: after 1h from fault detection
- Level 2 inducement: after 2h from fault detection
- Level 3 inducement: after 3h from fault detection

Interruption of DEF supply

- information activation on car panel: upon fault detection
- Level 1 inducement: after 1h from fault detection
- Level 2 inducement: after 2h from fault detection
- Level 3 inducement: after 3h from fault detection

EGR valve malfunctioning

- information activation on car panel: upon fault detection
- Level 1 inducement: after 1h from fault detection
- Level 2 inducement: after 2h from fault detection
- Level 3 inducement: after 3h from fault detection

Tampering with the monitoring systems of the ATS system

- information activation on car panel: upon fault detection
- Level 1 inducement: after 1h from fault detection
- Level 2 inducement: after 2h from fault detection
- Level 3 inducement: after 3h from fault detection

2.9 Control panel

Tab. 2.8 shows the control panel components.

2.8

POS.	DESCRIPTION
A	Switch key to start the panel and motor
B	Engine data or errors display
C	Top navigation menu arrow push button
D	Bottom navigation menu arrow push button
E	Data selection or entry push button
F	Engine operating status (green = no problem detected)

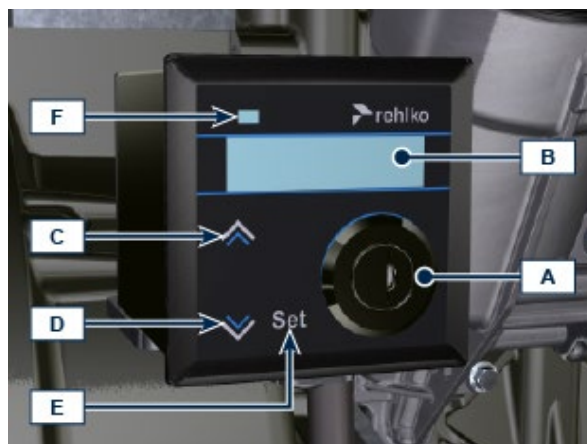

NOTE : if LED **F** is red, contact authorized **REHLKO** workshops to know what type of problem it is. Certain problems automatically switch off the engine.

Tab. 2.9 shows data that can be consulted on display **B** by pressing push buttons **C** or **D**.

NOTE : data described in **Tab. 2.9** can differ, therefore, consult the machine's manual.

2.9

DESCRIPTION

Operating hours

Hours left for maintenance

Engine rpm

Engine oil pressure

Coolant temperature

Torque used @ rpm (% used)

3 SAFETY INFORMATION

3.1 Safety information

- The intended use of the engine is in conformity with the machine on which it is mounted.
- Any use of the machine other than that described cannot be considered as complying with its intended purpose as specified by **REHLKO**.
- **REHLKO** declines all responsibility for any change to the engine not described in this manual made by unauthorized **REHLKO** personnel.
- A proper use of the engine, a strict observance of the rules listed below and the rigorous application of all these precautions will avoid the risk of accidents or injuries.
- Those who carry out the use and maintenance on the engine must wear the safety equipment and the accident-prevention guards.
- **REHLKO** declines all direct and indirect liability for failure to comply with the standards of conduct contained in this manual.
- **REHLKO** is not responsible for any unreasonable use or neglect that may cause a potential danger.

3.2 General remarks

3.2.1 Note for OEM

- When installing the KDI engines, always bear in mind that any variation to the functional systems may result in serious failures to the engine.
- Any improvement must be verified at **REHLKO** testing laboratories before application of the engine.
- In case the approval to a modification is not granted, **REHLKO** shall not be deemed responsible for any consequential failures or damages to the engine.
- Those who carry out the use and maintenance on the engine must wear the safety equipment and the accident-prevention guards.
- **REHLKO** declines all direct and indirect liability for failure to comply with the standards of conduct contained in this manual.
- **REHLKO** cannot consider every reasonably unforeseeable misuse that may cause a potential danger.

3.2.2 Note for end user

- The following indications are dedicated to the user of the machine in order to reduce or eliminate risks concerning engine operation and the relative routine maintenance work.
- The user must read these instructions carefully. Failure to do this could lead to serious danger for his personal safety and health and that of any persons who may be in the vicinity of the machine.
- On starting, make sure that the engine is as horizontal as possible, unless the machine specifications differ.
- Make sure that the machine is stable to prevent the risk of overturning.
- The engine must not operate in places containing inflammable materials, in explosive atmospheres, where there is dust that can easily catch fire unless specific, adequate and clearly indicated precautions have been taken and have been certified for the machine.
- To prevent fire hazards, always keep the machine at least one meter from buildings or from other machinery.
- Children and animals must be kept at a due distance from operating machines in order to prevent hazards deriving from their operation.

- Thoroughly wash and clean all the external parts of the engine before performing any operation, in order to avoid the accidental introduction of impurities/foreign bodies. Use only water and/or appropriate products to clean the engine. If cleaning engine with a pressure washer or steam cleaner, it is important to maintain a minimum distance of at least 200mm between the surface to be washed and the nozzle. Avoid directing the nozzle on electrical components, cable connections and sealed rings (oil seals etc). Thoroughly wash and clean the area surrounding the engine following the instructions provided by machine manufacturer.
- Fuel and oil are inflammable. The tank must only be filled when the engine is off. Before starting, dry any spilled fuel.
- Make sure that no soundproofing panels and the ground or floor on which the machine is standing have not soaked up any fuel.
- Fuel vapour is highly toxic. Only refuel outdoors or in a well ventilated place
- Do not smoke or use open flames when refuelling.
- During operation, the surface of the engine can become dangerously hot. Avoid touching the exhaust system in particular.
- Before proceeding with any operation on the engine, stop it and allow it to cool.
- Always open the radiator plug or expansion chamber with the utmost caution, wearing protective garments and goggles.
- The coolant fluid is under pressure. Never carry out any inspections until the engine has cooled.
- If there is an electric fan, do not approach the engine when it is still hot as the fan could also start operating when the engine is at a standstill.



Important

- The oil must be drained whilst the engine is hot. Particular care is required to prevent burns. Do not allow oil to come into contact with the skin because of the health hazards involved. It is recommended to use an oil intake pump.
- During operations that involve access to moving parts of the engine and/or removal of rotating guards, disconnect and insulate the negative wire (-) of the battery to prevent accidental short-circuits and to stop the starter motor from being energized.
- Check belt tension only when the engine is off.
- Fully tighten the tank cap each time after refuelling. Do not fill the tank right to the top but leave an adequate space for the fuel to expand.
- To start the engine follow the specific instructions provided in the engine and/or machine operating manual. Do not use auxiliary starting devices not originally installed on the machine (e.g. Startpilot).
- Before starting, remove any tools that were used to service the engine and/or machine. Make sure that all guards have been refitted.
- Do not mix fuel with elements such as oil or kerosene. Failure to comply with this prohibition will cause the non-operation of the catalyst and non-observance of the emissions declared by **REHLKO**.
- Pay attention to the temperature of the oil filter when the filter itself is replaced.
- Only check, top up and change the coolant fluid when the engine is off and reached the ambient temperature. Coolant fluid is polluting, it must therefore be disposed of in the correct way.
- Do not use air and water jets at high pressures on cables, connectors and injectors.
- Only use the eyebolts **A** installed by **REHLKO** to move the engine.
- The angle between each lifting chain and the eyebolts shall not exceed **15°** inwards for the base version and **0°** for ATS mounted version.
- The correct tightening of the lifting screws is **80 Nm**.
- Do not interpose spacers or washers between the eyebolts and engine head.
- Provided that the above requirements are met, if the lifting eyebolts are subject to permanent deformation (inwards), all subsequent lifting operations must be performed in order to prevent them from bending in the opposite direction.

BASE VERSION:

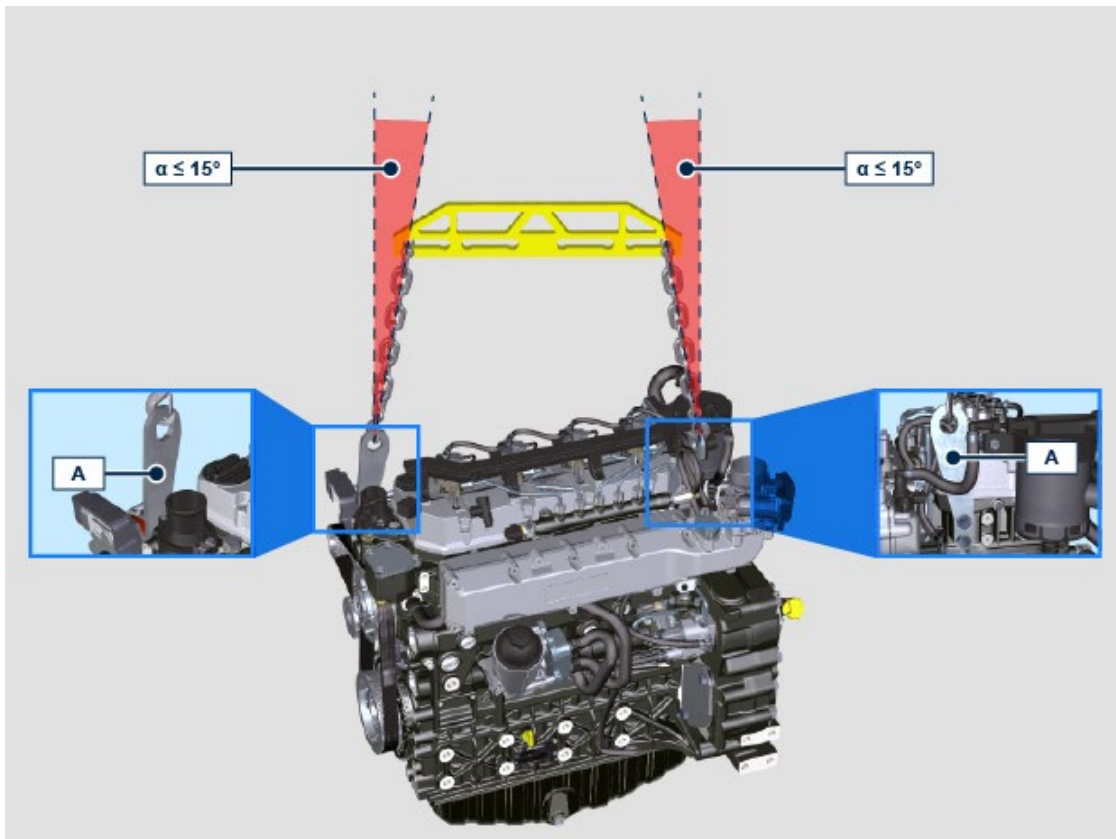

ATS MOUNTED:

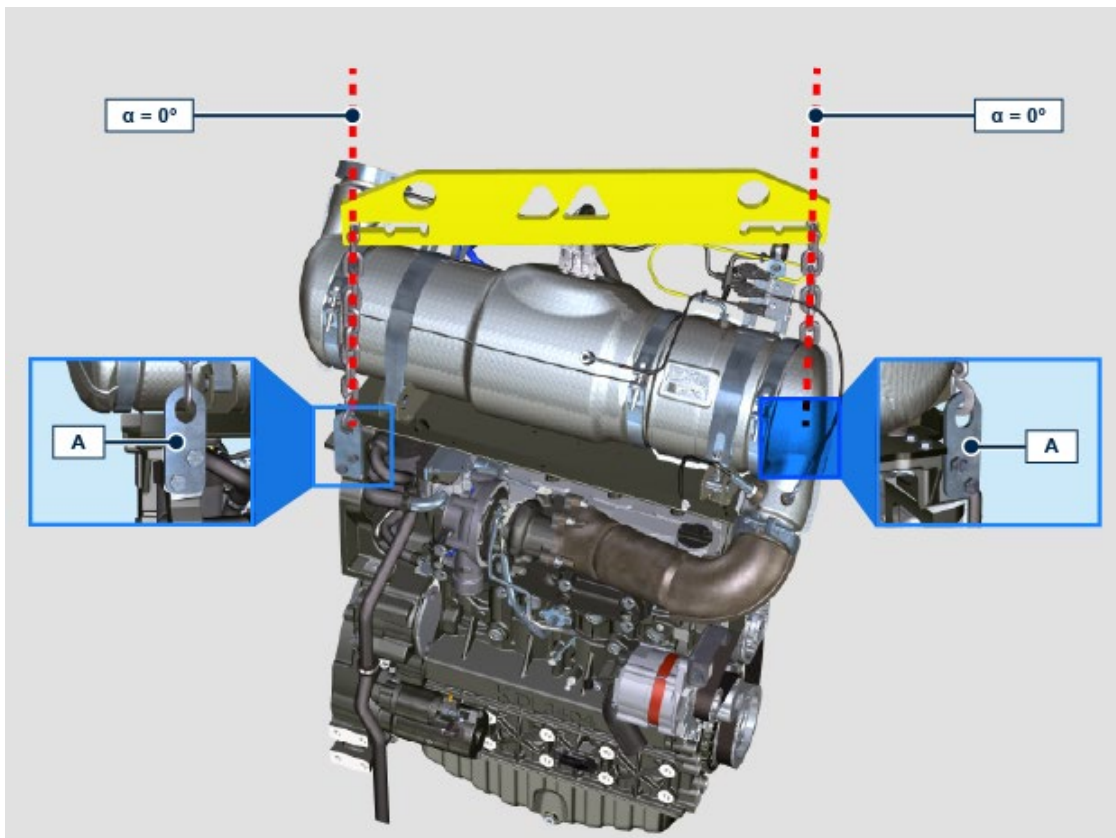







3.3 Safety signal description





- To ensure safe operation please read the following statements and understand their meaning.
- Also refer to your equipment manufacturer's manual for other important safety information.
- This manual contains safety precautions which are explained below.
- Please read them carefully.

Adhesive safety plates









The following is a list of the adhesive safety plates that may be found on the engine, which indicate potential points of danger to the operator.

NOTE: These stickers are applied on components engine by the machine manufacturer and some of them may be made of metal to resist at high temperatures.

	Read the Operation and Maintenance handbook before performing any operation on the engine.
	Hot Parts. Danger of burns.
	Presence of rotating parts. Danger of jamming or cutting.
	Presence of explosive fuel. Danger of fire or explosion.
	Presence of steam and pressurized coolant. Danger of burns.
Warnings	
<p>Hereunder is a list of safety warnings that may be found in the manual, which advise you to pay attention when carrying out particular procedures that may be potentially dangerous to the operator or things.</p>	
	<p>Danger This indicates situations of grave danger which, if ignored, may seriously threaten the health and safety of individuals.</p>

	Important This indicates particularly important technical information that should not be ignored.
	Warning This indicates that failure to comply with it can cause minor damage or injury.
<p>Safety guards Hereunder is a list of safety guards that must be worn prior to carrying out any type of operation and to avoid potential harm to the operator.</p>	
	Use suitable protective gloves before carrying out any type of operation.
	Use protective goggles before carrying out any type of operation.
	Use earmuffs before carrying out any type of operation.

3.4 Information and safety signals

<div style="text-align: center; margin-bottom: 10px;"> ACCIDENTAL START</div> <div style="display: flex; align-items: center;"> <div style="margin-right: 10px;">  </div> <div> <p>Accidental Starts can cause severe injury or death.</p> </div> </div> <p>Before working on the engine or equipment, disconnect the battery negative (-) wire.</p>	<div style="text-align: center; margin-bottom: 10px;"> HIGH PRESSURE FLUID RISK OF PUNCTURE</div> <div style="display: flex; align-items: center;"> <div style="margin-right: 10px;"></div> <div> <p>High Pressure Fluids can puncture skin and cause severe injury or death.</p> </div> </div> <p>Do not work on fuel system without proper training or safety equipment. Fluid puncture injuries are highly toxic and hazardous. If an injury occurs, seek immediate medical attention.</p>
<div style="text-align: center; margin-bottom: 10px;"> HOT PARTS</div> <div style="display: flex; align-items: center;"> <div style="margin-right: 10px;"></div> <div> <p>Hot Parts can cause severe burns.</p> </div> </div> <p>Engine components can get extremely hot from operation. Do not touch engine while operating or just after stopping.</p>	<div style="text-align: center; margin-bottom: 10px;"> EXPLOSIVE FUEL</div> <div style="display: flex; align-items: center;"> <div style="margin-right: 10px;"></div> <div> <p>Explosive fuel can cause fires and severe burns.</p> </div> </div> <p>Fuel is flammable and its vapours can ignite. Store fuel only in approved containers, in well ventilated, unoccupied buildings. Do not fill the fuel tank while the engine is hot or running, since spilled fuel could ignite if it comes in contact with hot parts or sparks from ignition.</p>

Never operate the engine with heat shields or guards removed.



ROTATING PARTS



Rotating Parts can cause severe injury.

Stay away while engine is in operation. Keep hands, feet, hair, and clothing away from all moving parts to prevent injury.

Never operate the engine with covers, shrouds, or guards removed.



LETHAL EXHAUST GASES



Carbon Monoxide can cause severe nausea, fainting or death.

Avoid inhaling exhaust fumes and never run the engine in a closed building or confined area. Carbon monoxide is toxic, odorless, colorless, and can cause death if inhaled.



ELECTRICAL SHOCK



Electrical Shock can cause injury.

Do not touch wires while engine is running.

Do not start the engine near spilled fuel.

Never use fuel as a cleaning agent.



EXPLOSIVE GAS



Explosive Gas can cause fires and severe acid burns.

Charge battery only in a well ventilated area. Keep sparks, open flames, and other sources of ignition away from the battery at all times. Batteries produce explosive hydrogen gas while being charged.

Keep batteries out of the reach of children.

Remove all jewelry when servicing batteries. Before disconnecting the negative (-) ground cable, make sure all switches are OFF.

If ON, a spark will occur at the ground cable terminal which could cause an explosion.



CALIFORNIA WARNING - DECLARATION 65

Engine exhaust from this product contains chemicals known to the State of California to cause cancer, birth defects, or other reproductive harm.

3.5 Safety and environmental impact

Every organisation has a duty to implement procedures to identify, assess and monitor the influence of its own activities (products, services, etc.) on the environment. Procedures for identifying the extent of the impact on the environment must consider the following factors:

- Liquid waste.
- Waste management.
- Soil contamination.
- Atmospheric emission.
- Use of raw materials and natural resources.
- Regulations and directives regarding environmental impact.

In order to minimise the impact on the environment, **REHLKO** now provides a number of indications to be followed by all persons handling the engine, for any reason, during its expected lifetime. - All components and fluids must be disposed of in accordance with the laws of the country in which disposal is taking place.

- Keep the fuel and engine control systems and the exhaust pipes in efficient working order to limit environmental and noise pollution.

- When discontinuing use of the engine, select all components according to their chemical characteristics and dispose of them separately.

4 INFORMATION ABOUT USE

4.1 Pre-start check



Important

- Read carefully the following pages and carry out the operations described below in accordance with the instructions specified.
- Non compliance with the operations described in the following pages involves the risk of damages to the engine and vehicle on which it is installed as well as personal and/or property damage.
- Increase the frequency of maintenance operations in heavy working conditions (engine starts but stops, very dusty and hot environments, etc...).
- Check that the minimum required DEF quantity is present inside the DEF tank. Refer also to the car documentation to check the DEF level required for engine correct operation.

4.2 Running-in period

NOTE: For the first 50 hours of engine operation, it is advisable not to exceed 75% of the maximum power supplied.

4.3 Starting and turning off

4.3.1 Starting

1. Check the level of the engine oil, fuel and coolant and fill if necessary ([Par. 4.5](#) e [Par. 4.6](#)).
2. Put the ignition key in the ignition switch (if supplied).
3. Turn the key to **ON** position.
4. Turn the key beyond the **ON** position and release it when the engine starts (the key will return into ON position automatically).



Important

- Do not actuate the starter for more than 15 seconds at a time. If the engine does not start, wait for one minute before repeating attempt.
- If engine does not start after two attempts see [Tab. 7.1](#) and [Tab. 7.2](#) to found the cause.

4.3.2 After starting



Warning

- Make sure that all the warning lights on the control panel are off when the engine is running.
- Run at minimum speed for a few minutes according to table (except constant speed engine).

NOTE: To avoid damaging the engine do not use it mostly at idle for a long time (**MAX 30min.**).

AMBIENT TEMPERATURE	TIME
≤ -20°C	2 minutes
from -20°C a -10°C	1 minutes
from -10°C a -5°C	30 seconds
from -5°C a 5°C	20 seconds
≥ 5°C	15 seconds

4.3.3 Turning off

1. Do not turn off the engine when it is running at the maximum rotation speed (except constant speed engine).
2. Before turning it off, keep it idle at minimum speed for about 1 minute.
3. Turn the key to **OFF** position.

4.4 Refuelling



Important

- Before proceeding with operation, read [Par. 3.2.2](#) .



Danger

- Fill the engine off.
- The only approved fuels are those listed in [Tab. 2.3](#) .
- In those countries where fuel has a high sulphur content, its is advisable to lubricate the engine with a high alkaline oil or alternatively to replace the lubricating oil recommended by **REHLKO** more frequently.
- To avoid explosions or fire outbreaks, do not smoke or use open flames during the operations.
- Fuel vapours are highly toxic. Only carry out the operations outdoors or in a well ventilated place.
- Keep your face well away from the fuel fill to prevent harmful vapours from being inhaled.
- Dispose of fuel in the correct way and do not litter as it is highly polluting.
- When refuelling, it is advisable to use a funnel to prevent fuel from spilling out. The fuel should also be filtered to prevent dust or dirt from entering the tank.
- Do not overfill the fuel tank. Leave room for the fuel to expand.

NOTE: At the first fuelling or if the tank was empty filling the fuel system ([Par. 6.3 point 8](#)) .

4.5 Oil filling

**Important**

- For safety precautions see **Par. 2.4** .
- Before proceeding with operation, read **Par. 3.2.2** .

1. Loosen the oil filler cap **A** or the oil filler cap **C** if the cap **A** is not accessible.
2. Add the type oil recommended (**Tab. 2.2**).

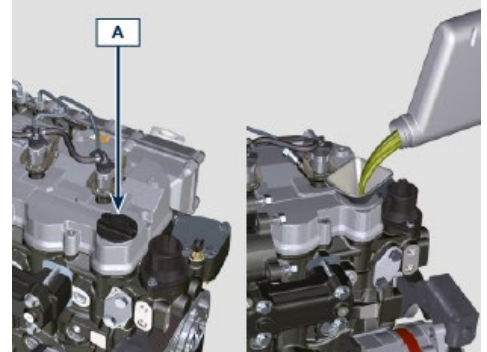

3. Before checking oil engine needs to be level.
4. Remove the oil dipstick **B** and check that the level is up to but does not exceed the **MAX** .
5. If level is not at the **MAX** . level, add additional oil.
6. Re-tighten the cap **A** .

**Important**

- Do not use the engine with the oil level below the minimum.
- Oil dipsticks may vary depending on engine configuration.

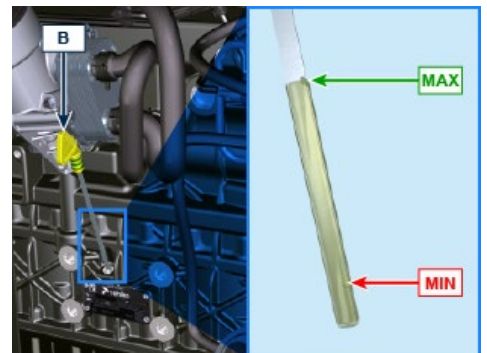

4.6 Coolant filling

Important

- Before proceeding with operation, read [Par. 3.2.2](#).

Warning

- An anti-freeze protection liquid (ANTIFREEZE) - mixed with decalcified water - must be used.
- The freezing point of the refrigerant mixture depends on the amount concentration in water.
- As well as lowering the freezing point, the antifreeze also raises the boiling point.
- A 50% mixture is recommended to ensure a general level at protection prevents the formation of rust, galvanic currents and calcium deposits.

NOTE: Before proceeding with any operation on the engine, stop it and allow it to cool.

Warning

- Presence of steam pressurized coolant danger of burns.
1. Loosen the cap **A** and fill the radiator with coolant composed of: 50% ANTIFREEZE and 50% decalcified water.
 2. Top liquid up until the pipes inside the radiator are covered by about 5 mm. Do not overfill the radiator, but leave room for the coolant to expand.
 3. For engines equipped with expansion tank, pour in fluid until reaching the max level mark **B**.
 4. Re-tighten the cap **A**.
 5. After a few hours of operator, stop the engine and allow the liquid to cool returns to a ambient temperature and check the coolant level again.

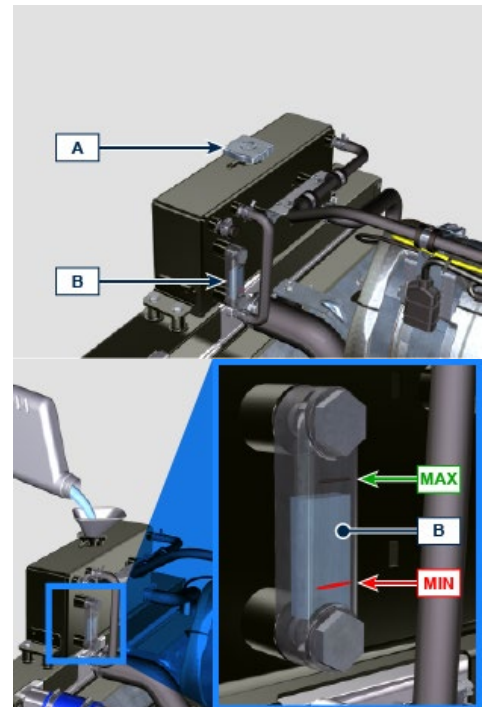





4.7 DEF filling

NOTE: Refer to the technical documentation of the vehicle.

4.8 Inducement SCR

Below is a list of the warning lights that may light up on the machine panel to indicate inducement levels. Refer to the machine manual for the operations to be carried out according to the activated warning lights.

CONDITION	EU	USA	WARNING LIGHT *1	DISPLAY MODE	INDUCEMENT LEVEL
Low DEF level	< 10%	< 15%		Fixed	
DEF level below MIN	< 2.5%	< 5%		Flashing	Level 1 inducement activated
DEF level below MIN	0%	< 2.5%		Fixed	Level 2 inducement activated
DEF tank empty		0%		Flashing	Level 3 inducement activated

*1: The warning lights be different – consult the machine manual.

4.9 ATS regeneration strategy



Only for Stage V configurations (see Chap. 1 Par. ATS)

You can intervene on the machine control panel for the DPF regeneration operations "only if requested by means of specific warning lights or messages on the control panel".

Tab. 4.11 describes the level of particulate accumulation, the relationship with the warning lights that will light up on the panel, the performance limitations of the engine and the operator's options intervention.

Forced regeneration must be executed in accordance with the machine instructions.

4.11

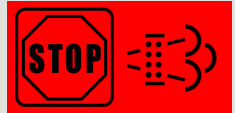
SOOT LEVEL	WARNING LAMPS *1	ENGINE DE-RATE	OPERATOR POSSIBLE ACTIONS	OPERATING CONDITIONS
Level 0				
Level 1				<ul style="list-style-type: none"> No condition
Level 2				
Level 3	 <p>Fixed</p>		Forced Regeneration is Necessary.	<ul style="list-style-type: none"> Coolant temperature at 60 °C Do not switch the engine off Stationary vehicle No load applied to the engine *2
Level 4	 <p>Flashing</p>	Engine de-rate.	Forced Regeneration is Necessary.	<ul style="list-style-type: none"> Coolant temperature at 60 °C Do not switch the engine off Stationary vehicle No load applied to the engine *2
Level 5	 <p>Flashing</p>	Strong Engine de-rate.	Contact an authorized REHLKO workshop. Service Regeneration Required	REGENERATION via REHLKO software

*1: The warning lights be different – consult the machine manual.

*2: Unless stated otherwise in the machine manual.

**Warning**

- Forced regenerations must only be executed if required by the ECU when the "HIGH SOOT" warning light goes on (due to a Level 3 - 5 particulate accumulation).
- Do NOT execute the forced regenerations if not required by the ECU (due to a Level 0 - 2 particulate accumulation).
- The minimum engine speed increases during the forced regeneration phases.
- Repeated forced regenerations cause significant engine oil contamination by the fuel.
- The operations described in Par. 5.3 or 5.4 must be executed after every forced regeneration.
- If the regeneration inhibition function is misused, the particulate accumulation level will increase within a short time.
- The engine oil filter and oil must be changed after a Service Regeneration is completed via **REHLKO** software
- (Level 5 Particulate accumulation).
- Fuel contamination allowed in the engine oil is 3% MAX.
- Any engine load must be eliminated during forced regeneration so as to prevent damaging the ATS *2 system.
- Do not switch the engine off during level 3, 4 and 5 regeneration so as to prevent damaging the ATS system.

5 INFORMATION ABOUT MAINTENANCE

5.1 Useful information about maintenance

- This chapter shows all operations described in the Tab. 5.1 and Tab. 5.2 if you have the skills appropriate may be directly carried out by the user.
- Periodic inspection and maintenance operations must be carried out as indicated in this manual and are the responsibility of the user.
- Failure to comply with these service and maintenance intervals increases the risk of technical damage to the engine. Any non compliance makes the warranty become null and void.
- In order to prevent personal and property damage read carefully the instructions listed below before proceeding with any operation of the engine.



Important

- Before proceeding with operation, read **Par. 3.2.2** .



Warning

- Inspections must be made when the engine is off and cold.
- Place engine on level surface to ensure accurate measurement of oil level.
- Before starting, to avoid spillages of oil make sure that:
 - the oil dipstick is inserted correctly;
 - oil drain plug and oil filler cap are tightened firmly.

5.2 Periodic maintenance

The intervals of preventive maintenance in **Tab. 5.1** and **Tab. 5.2** refer to the engine operating under normal operating conditions with fuel and oil meeting the recommended specifications.

5.1

CLEANING AND CHECKING			
OPERATION DESCRIPTION	PERIOD (HOURS)		
	100	250	500
Engine oil level ⁽⁸⁾			
Coolant level ⁽⁸⁾⁽⁹⁾			
Cartridge dry-type air filter ⁽²⁾			
Radiator heat-exchange surface and Intercooler ^{(2) (8)}			
Rubber components			

5.2

OPERATION DESCRIPTION		REPLACEMENT		
		PERIOD (HOURS)		
		500	2000	5000
Engine oil ⁽¹⁾				
Oil filter cartridge ⁽¹⁾				
Fuel filter and pre-filter cartridge ⁽¹⁾				
Cartridge dry-type air filter ⁽²⁾				
Delta-P > DPF pipes ⁽⁶⁾				
DEF filter cartridge ⁽¹⁾ ⁽⁶⁾ ⁽¹¹⁾				
Coolant hoses ⁽⁶⁾ ⁽⁷⁾				
Fuel line pipes ⁽⁶⁾ ⁽⁷⁾				
Intake manifold hose (air filter - intake manifold) ⁽⁶⁾ ⁽⁷⁾				
Poly-V belt ⁽⁶⁾				
Coolant	OAT ⁽⁶⁾			
	HOAT ⁽⁶⁾ ⁽¹⁰⁾			

1 - In case of low use: 12 months.

2 - The period of time that must elapse before checking the filter element depends on the environment in which the engine operates. The air filter must be cleaned and replaced more frequently under very dusty conditions.

6 - Contact authorized **REHLKO** workshops.

7 - The replacement interval is only an indication, it strongly depends from environmental condition and hose status detected during regular visual inspection.

8 - The first check must be done after 10 hours.

9 - Test the coolant condition annually with coolant test strips.

10 - It is recommended to have SCA (Supplemental Coolant Additives) added at the first maintenance interval.

11 - If the DEF tank is not equipped with filtering system, it must be replaced at 500h.

5.3 Oil level check

1. Loosen the oil filler cap **A** or the oil filler cap **C** if the cap **A** is not accessible.
2. Remove the oil dipstick **B** and check that the level is up to **MAX**.
3. Pour in recommended oil until reaching the **MAX** level mark.
4. Reinstall the oil dipstick **B** completely.
5. Re-tighten the cap **A** or **C**.



Important

- Do not use the engine with the oil level below the **MIN**.

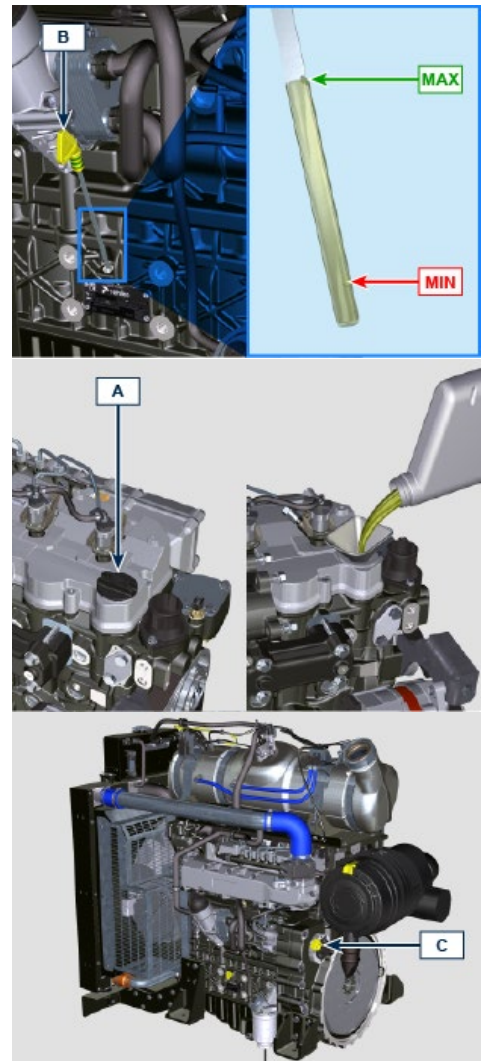

5.4 Air filter check

**Important**

- Before proceeding with operation, read [Par. 3.2.2](#) .
- When the cartridge **G** is dirty, do not clean it but replace cartridges **B** and **G**.

NOTE: Components not necessarily supplied by **REHLKO** .

1. Release the two clasps **F** of the cover **A** .
2. Remove the cartridges **B** and **G** .
3. Clean the inside components **A** and **D** with a damp cloth.
4. Check the condition of cartridge **B** , replace it in case of suspecting of high level of clogging even if the hours of **Tab. 5.2** are not reached.
5. Reinstall:
 - cartridges **G** and **B**.
 - the cover **A** checking the right tightness of clasps **F** .

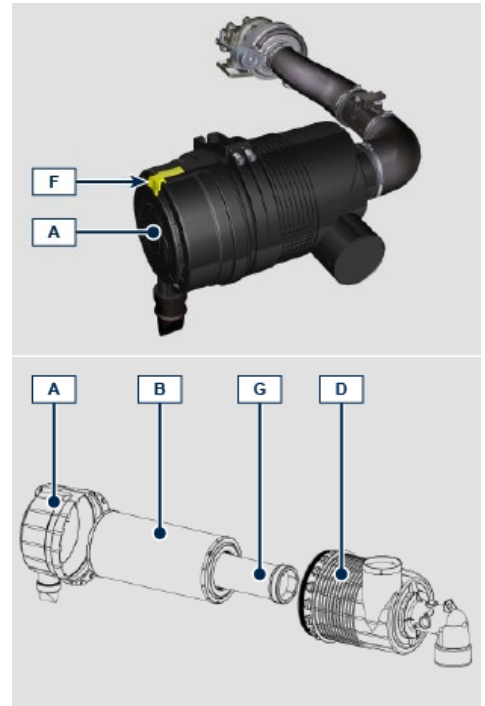

5.5 Check of the radiator heat - exchanger surface

**Danger**

- For safety precautions see [Chap. 3](#) .

NOTE: Component not necessarily supplied by **REHLKO** .

**Important**

- Before proceeding with operation, read [Par. 3.2.2](#) .
 - Wear safety goggles when using compressed air.
 - The radiator heat-exchange surface must be cleaned on both.
1. Check the radiator heat-exchange surface **D** .
 2. Clean the surface with a brush soaked in special detergent if it is clogged.

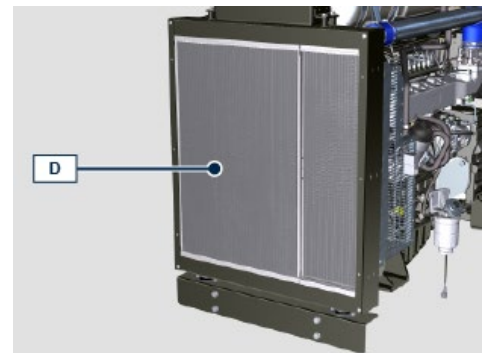

5.6 Rubber hoses check



Danger

- For safety precautions see [Cap. 3](#).

The check is carried out by exerting a slight deflection or bending along the pipe and near the hose clamps. Components must be replaced if they have clear signs of cracks, tears, cuts, leaks and do not retain a certain degree of elasticity.



Important

- Before proceeding with operation, read [Par. 3.2.2](#).
 - If hoses are damaged contact an authorized **REHLKO** workshop.
 - For other pipes not illustrated refer to the technical documentation of the vehicle.
1. Check that the:
 - Fuel system pipes.
 - Cooling circuit hoses.
 - Oil circuit pipes
 - Air system hoses.

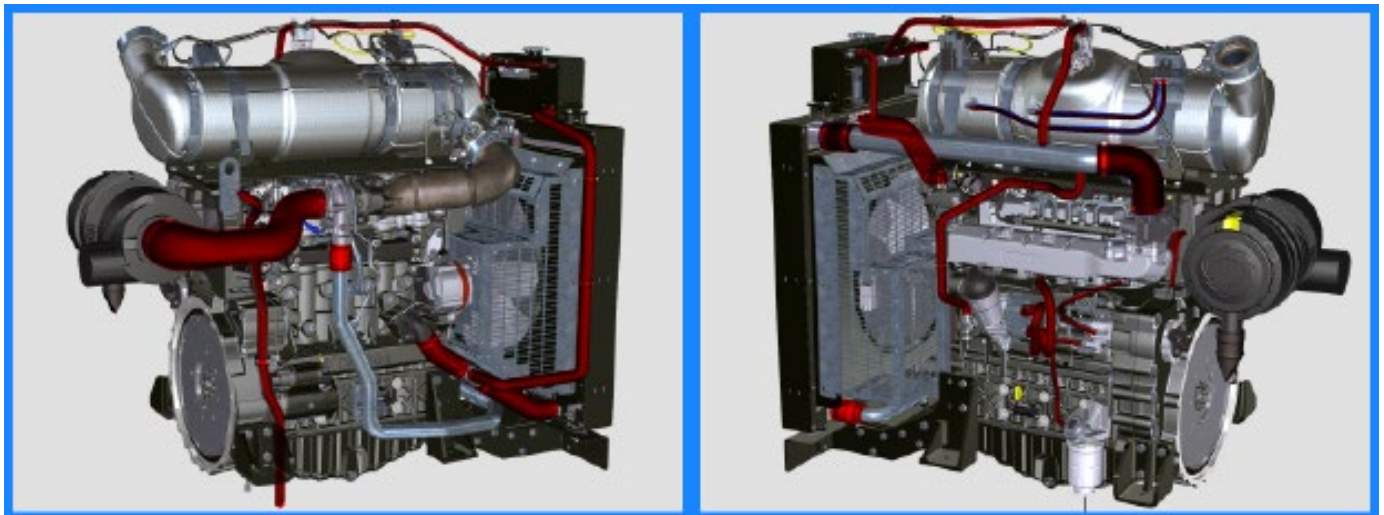

5.7 Check coolant level



Important

- Before proceeding with operation, read [Par. 3.2.2](#) .



Danger

- For safety precautions see [Chap. 3](#) .

NOTE : Before proceeding with any operation on the engine, stop it and allow it to cool.



Warning

- Presence of steam pressurized coolant danger of burn.

NOTE : Component not necessarily supplied by **REHLKO** .

1. Start the engine without the radiator cap **A** .
2. Top liquid up until the pipes inside the radiator are covered by about 5 mm.
3. **Top up if necessary.**
4. Do not overfill the radiator, but leave room for the coolant to expand.
5. Reinstall radiator cap **A**
6. For engines equipped with expansion tank, check that the fluid is until reaching the **max** level mark **B** .

NOTE : For coolant filling see [Par. 4.6](#) .



Warning

- Before starting make sure that the radiator cap and cap, if present, are installed correctly to avoid spillage of liquid or vapour at high temperatures.

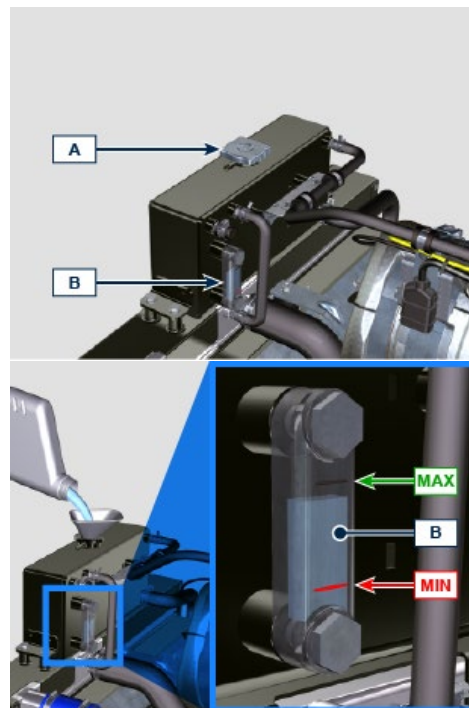

5.8 Filter cartridge and fuel pre-filter check



Important

- Before proceeding with operation, read [Par. 3.2.2](#) .



Warning

- For safety precautions see [Cap. 3](#) .

When turn on lights on control water filter cartridge fuel:

1. Gently loosen the wing screw **A** without removing it.
2. Drain the water if present.
3. Re-tighten the wing screw **A** as soon as the fuel begins to flow.

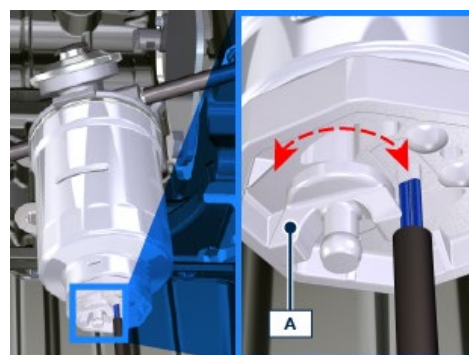

5.9 Product preservation



Important:

- If the engines are not to be used for 6 months, they must be protected by carrying out the operations described in Engine storage (up to 6 months) ([Par. 5.11](#)).
- If the engine is still not in use after the first 6 months, it is necessary to carry out a further operation to extend the protection period (more than 6 months) ([Par. 5.12](#)).
- If the engine is not to be used for an extended period, the protective treatment procedure must be repeated within 24 months of the previous one.

5.10 Engine storage up to 6 months

Before storing the engine check that:

- The environments are not humid or exposed to bad weather. Cover the engine with a proper protective sheet against dampness and atmospheric contaminants.
- The place is not near electric panel.
- Avoid storing the engine in direct contact with the ground.

5.11 Engine storage over 6 months

Follow the steps described in [Par. 5.11](#) .

1. Engine oil replacement ([Par. 6.1](#)).
 2. Refuel with fuel additives for long storage.
 3. With expansion tank: make sure that the coolant is up to the MAX level.
 4. Without expansion tank: Top liquid up until the pipes inside the radiator are covered by about 5 mm. Do not overfill the radiator, but leave room for the fuel to expand.
 5. Start the engine and keep it idle at minimum speed for 2 minutes.
 6. Bring the engine to 3/4 of the MAX speed for 5÷10 minutes.
 7. Turn off the engine.
 8. Completely empty the fuel tank.
 9. Spray SAE 10W-40 on the exhaust and intake manifolds.
 10. Seal the exhaust and intake ducts to prevent foreign bodies from entering.
 11. When cleaning the engine, if using a pressure washer or steam cleaning device, avoid directing the nozzle on electrical components, cable connections and sealed rings (oil seals etc). If cleaning engine with a pressure washer or steam cleaner, it is important to maintain a minimum distance of at least 200mm between the surface to be washed and the nozzle - avoiding absolutely electrical components such as alternators, starter motors and engine control units (ECU).
 12. Treat non-painted parts with protective products.
 13. Fill the DEF tank to the MAX level allowed.
- If the engine protection is performed according to the suggestions indicated no corrosion damage should occur.

5.12 Engine starting after storage



Warning:

- Over time, lubricants and filters lose their properties, so it is important consider whether they need replacing, also based on the criteria described in **Tab. 5.2**.
1. Remove the protective sheet.
 2. Use a cloth soaked in degreasing product to remove the protective treatment from the external parts.
 3. Inject lubricating oil (no more than 2 cm³) into the intake ducts.
 4. Refill the tank with fresh fuel.
 5. Make sure that the oil and the coolant are up to the MAX level.
 6. Proceed with the disposal of the DEF contained in the tank; replace the DEF pump filter and wash the DEF tank/circuit with hot distilled water.
 7. Check the DEF injector at an authorized **REHLKO** workshop.
 8. Start the engine and keep it idle at minimum speed for a two about minutes.
 9. Bring the engine to 75% of MAX rated speed for 5 to 10 minute.
 10. Stop the engine while the oil is still hot (**Par. 6.1**), discharge the protective oil in a suitable container.
 11. Replace the filters (air, oil, fuel) with original spare parts.
 12. Pour new oil (**Par. 4.5**) up to the MAX level.
 13. Empty the cooling circuit completely and pour in the new coolant up to the MAX level (**Par. 4.6**).

5.13 Unused machine

If the machine is not used for a certain amount of time, follow the operations below:

Operations for the engine

5.3

POINT	PERIOD	OPERATION
1	up to 2 months	<ul style="list-style-type: none"> • The place must be dry and fresh throughout the period in which the machine is not used. • Consult the machine's manual to disconnect the battery (before disconnecting the battery, wait for minimum 5 mins after turning off the engine). • Make sure the engine is not exposed to direct sunlight. • Make sure the engine is not near any heat sources.
1a	Start-up after 2 months	<ul style="list-style-type: none"> • Before starting the engine, check Para. 5.2 for maintenance operations. • Consult the machine's manual to connect the battery and start the engine.
2	up to 9 months	<ul style="list-style-type: none"> • Perform the operations described in point 1. • Perform the operations described in Para. 5.6. • Start the engine at least every 4 months as per operations described in point 1a: • Avoid sudden accelerations for the first few minutes. • Bring the engine to the working temperature by pressing the accelerator 3/4 from MAX. • Leave the engine running at minimum speed for a few minutes and turning off the engine.

2a	Start-up after 9 months	<ul style="list-style-type: none"> • Before starting the engine, check Para. 5.2 for maintenance operations. • Consult the machine's manual to connect the battery and start the engine. • Avoid sudden accelerations for the first few minutes.
3	over 9 months	<ul style="list-style-type: none"> • Perform the operations described in point 1 and 2.
3a	Start-up after 9+ months	<ul style="list-style-type: none"> • Before starting the engine, check Para. 5.2 for maintenance operations. • Check the quality of coolant from the relative testing strips. • Consult the machine's manual to connect the battery and start the engine. • Avoid sudden accelerations for the first few minutes.

Operations for the SCR system

5.4

POINT	PERIOD	OPERATION
1	up to 2 months	<ul style="list-style-type: none"> • Perform the operations described in point 1 of Tab. 5.3 • Fill the AdBlue®/DEF tank with AdBlue®/DEF to the MAX level • The ambient temperature must be kept between -40 and 40 °C • Do not disconnect any electrical or hydraulic connections
1a	Start-up after 2 months	<ul style="list-style-type: none"> • Before starting the engine, check Para. 5.2 for maintenance operations. • Consult the machine's manual to connect the battery and start the engine.
2	up to 9 months	<ul style="list-style-type: none"> • Perform the operations described in point 2 in Tab. 5.3 • Fill the AdBlue®/DEF tank with AdBlue®/DEF to the MAX level • The ambient temperature must be kept between -40 and 25 °C • Do not disconnect any electrical or hydraulic connections
2a	Start-up after 9 months	<ul style="list-style-type: none"> • Before starting the engine, check Para. 5.2 for maintenance operations. • Consult the machine's manual to connect the battery and start the engine.
3	over 9 months	<ul style="list-style-type: none"> • Perform the operations described in point 3 of Tab. 5.3 • Fill the AdBlue®/DEF tank with AdBlue®/DEF to the MAX level • The ambient temperature must be kept between -40 and 25 °C • Do not disconnect any electrical or hydraulic connections
3a	Start-up after 9+ months	<ul style="list-style-type: none"> • Before starting the vehicle, proceed as follows: • Replace the AdBlue®/DEF in the tank (consult the machine's manual) • Replace the AdBlue®/DEF filter (Par. 6.5) • Check Par. 5.2 for maintenance frequency. • Consult the machine's manual to connect the battery. • Start the engine. If faults are detected when starting the engine or during operation, turn off the engine and wait 5 mins before starting the engine. • If the fault persists, contact REHLKO authorised workshops.

6 INFORMATION ABOUT REPLACEMENTS

6.1 Engine oil replacement



Danger:

- Disconnect the negative wire (-) from the battery to avoid accidental engine starting.



Important:

- Before proceeding with operation, read [Cap. 3](#).



Important :

- Place engine on level surface to ensure accurate measurement of oil level.
Before proceeding, perform the operation described in [Par. 6.2](#) - Point 1.

NOTE: Perform this operation with warm engine, to get a better fluidity of the oil and get a full discharge of oil and impurities contained in it.

1. Loosen the oil filler cap **A** or the oil filler cap **C** if the cap **A** is not accessible.
2. Remove the oil dipstick **B**.
3. Remove the oil drain plug **D** and the gasket **E** (the oil drain plug is on both sides of the oil sump).
4. Drain oil in an appropriate container (For the exhausted oil disposal, refer to ([Par. 6.6 DISPOSAL and SCRAPPING](#))).
5. Replace gasket **E**.
6. Tighten the drain oil plug **D** (tightening torque at **35 Nm**).
7. Perform the operation described in [Par. 6.2](#) - point 2 to 5.

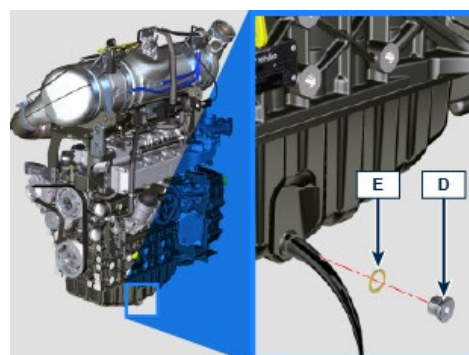
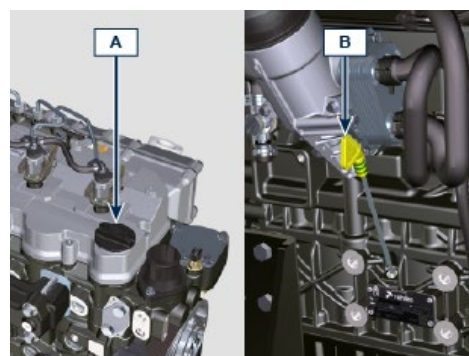

8. Add the type oil recommended ([Tab. 2.1](#) and [Tab. 2.2](#)).



Important :

- Do not exceed the **MAX** level on the dipstick.
- Do not use the engine with the oil level below the **MIN** .

9. Fit and remove the oil dipstick **B** to check the level. Pour in fluid until reaching the **MAX** level mark.
10. Upon completion, reinstall the oil dipstick **B** completely.
11. Tighten the cap **A** or **C** .

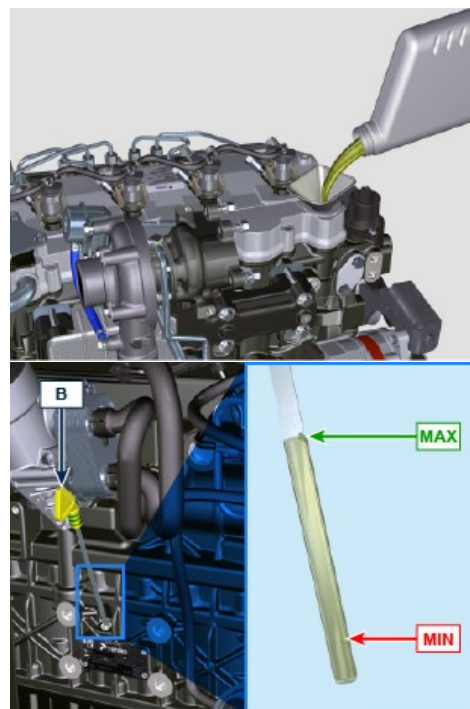

6.2 Oil filter cartridge replacement



Important

- Before proceeding with operation, read [Par. 3.2.2](#)
- Electric/pneumatic screwdrivers are forbidden



Warning:

- Oil filter cartridge replacement (Par. 6.2) and fuel filter replacement ([Par. 6.3](#)).
- In case of low use replace it 12 months.
- For disposal of oil filter cartridge and fuel filter refer to [Par. 6.6 DISPOSAL and SCRAPPING](#) .

1. Unscrew cartridge holder cover **A** by performing three complete turns and wait 1 minute.

NOTE: This operation allows to oil contained in the support **F** to flow into the oil sump in the correct way.

2. Unscrew cartridge holder cover **A** and check that the oil in the lub. oil filter support **F** has flowed towards the oil sump.
3. Remove the cap **A** as well as the oil cartridge **B** from the oil filter support.
4. Remove and replace the oil cartridge **B** with a new one. Remove and replace the gaskets **C** , **D** and **E** with new ones.
5. Fit and tighten the cover **A** on the oil filter support **F** (tightening torque of **25 Nm**).

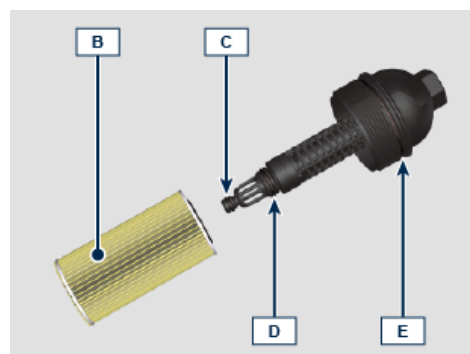
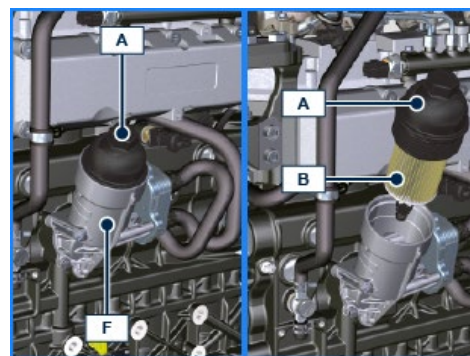

6.3 Filter cartridge and fuel pre-filter replacement

NOTE: The fuel filter is situated on the crankcase of the engine or it may be assembled on the frame of the vehicle.



Important

- Before proceeding with operation, read [Par. 3.2.2](#)



Warning

- In case of low use replace it 12 months.
- For disposal of oil filter cartridge and fuel filter refer to [Par. 6.5 DISPOSAL and SCRAPPING](#)

1. Disconnect the cable A of the water presence sensor C.
2. Remove the water presence sensor C from its cartridge B.
3. Loosen the cartridge B using the appropriate wrench.
4. Lubricate the gasket D of the new cartridge B.



Important:

- Do not fill the new cartridge B with fuel.
5. Tighten the new empty cartridge B on the diesel fuel filter support E using the special wrench (tightening torque of 17 Nm).
 6. Tighten the water presence sensor C on the new cartridge B (tightening torque of 5 Nm).
 7. Reconnect the cable A of the water presence sensor C.

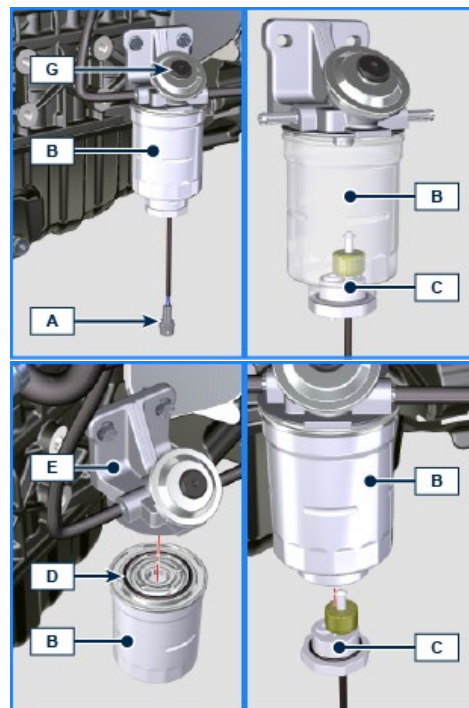

NOTE: Bleeding.

8. Push repeatedly the button G in order to fill the circuit.

6.4 Air filter cartridge replacement



Important

- Before proceeding with operation, read [Par. 3.2.2](#)

NOTE: Component not necessarily supplied by REHLKO .

1. Pull insert **F** to unlock cover **A** .
2. Rotate counter clockwise and remove cover **A** .
3. Remove the cartridges **B** and **G** .
4. Fit cartridges **G** and **B** .
5. Fit cover **A** by performing the operations indicated in points 2 and 1 in the reverse order.

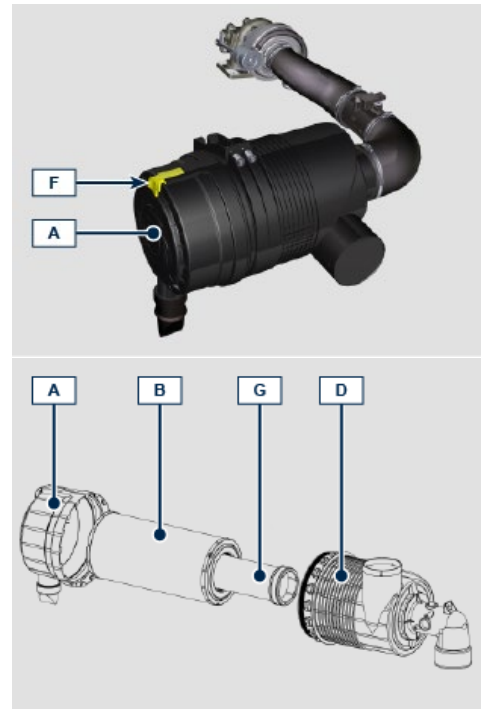

6.5 Replacement of DEF filter



Warning

- Before proceeding with operation, read [Par. 3.2.2](#)
- Do not lubricate gaskets A with oil or fuel.
- Filter D includes gaskets A in the package.
- Avoid any type of contamination during replacement.
- Before starting any operations, make sure the key on the machine's panel is OFF and the DEF pump has executed the circuit emptying operation.

1. Loosen cap B.

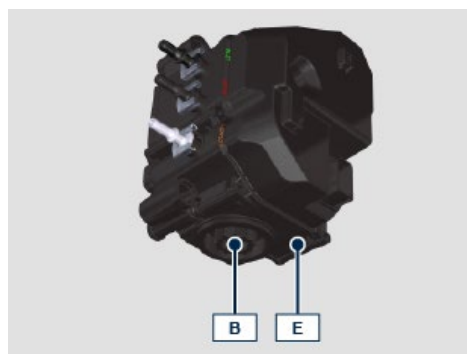

1. Remove cap B and extract filter bracket C.
2. Extract filter D.
3. Use warm DEF to clean the seat of filter D on pump E if impurities are detected.
4. Lubricate the A gaskets with DEF or distilled water.
5. Place the filter bracket C together with filter D inside pump E.
6. Tighten cap B (tightening torque of 20 Nm).

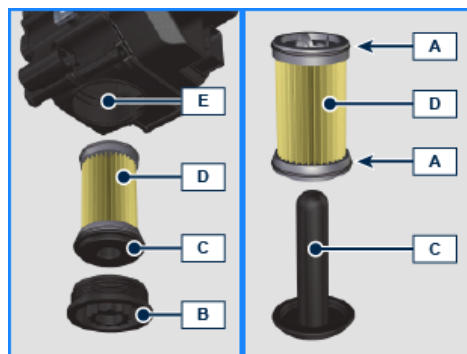

6.6 Disposal and scrapping

- In case of scrapping, the engine shall be disposed of in appropriate locations, in conformity with the law in force.
- Before scrapping, it is necessary to separate the rubber or plastic parts from the rest of the components.
- The parts only composed of plastic material, aluminium and steel can be recycled if collected by the appropriate centers.
- Waste oil must properly be recycled and disposed of in the correct way to safeguard the environment. According to the laws in force, it is classified as hazardous waste, therefore it must be collected by the appropriate centers.

7 INFORMATION ABOUT FAILURES

7.1 Useful information about failures

- This chapter contains information about the problems that may appear during engine operation with its causes and trouble shooting **Tab. 7.2** .
- In some cases, you shall turn off the engine immediately to avoid further damage **Tab. 7.1** .

7.1

THE ENGINE MUST BE IMMEDIATELY TURNED OFF WHEN

1	Warning RED light turn on
2	The oil pressure indicator light turns on while running
3	The engine rpms suddenly increase and decrease
4	A sudden and/or unusual noise is heard
5	Colour the exhaust fumes suddenly darkens

7.2

TROUBLES	POSSIBLE CAUSE	SOLUTION
Warning YELLOW light turn on	Engine ECU has detect a malfunctions	Contact REHLKO authorised workshops
The engine does not start	Sulphated battery terminals corroded	Clean the battery terminals
	Battery voltage too low	Recharge the battery or replace it
	Low fuel level	Refuel
	Frozen fuel	Contact REHLKO authorised workshops
	Clogged fuel filter	Replace with a new filter
	Air suction in fuel system	Contact REHLKO authorised workshops
	Clogged air filter	Replace with a new filter
	Clogged pipes	Contact REHLKO authorised workshops
	Intake or exhaust system clogged	Replace with a new fuse; if the problem persists, Contact REHLKO authorised workshops
	Intake or exhaust system clogged	Contact REHLKO authorised workshops
Engine starts but stops	Inefficient electrical connections	Clean the electrical contacts; if the problem persists, Contact REHLKO authorised workshops
	Sulphated battery terminals	Clean the battery terminals
	Clogged fuel filter	Replace with a new filter and clean the tank
	Clogged fuel pipes	Contact REHLKO authorised workshops
Engine doesn't rev up	Safety protocol in starting	Wait some seconds
	Throttle to MAX in starting	Release the throttle and wait some seconds
RPM instability at idle speed	Clogged fuel pipes	Contact REHLKO authorised workshops

Numero dei giri al minimo basso	Clogged fuel pipes	Contact REHLKO authorised workshops
	Poor quality fuel	Clean the tank and refuel with quality fuel
Blue smoke	High oil sump level	Replace the engine oil; if the problem persists, Contact REHLKO authorised workshops
	Clogged air filter	Replace with a new filter
Excessive fuel consumption	Clogged air filter	Replace with a new filter
	High oil sump level	Replace the engine oil; if the problem persists, Contact REHLKO authorised workshops
Engine lost its initial performance	Clogged air filter	Replace with a new filter
	Clogged fuel pipes	Contact REHLKO authorised workshops
	Cheap fuel	Clean the tank and refuel with quality fuel
	High oil sump level	Replace the engine oil; if the problem persists, Contact REHLKO authorised workshops
Slow acceleration	Clogged fuel filter	Replace the fuel filter
Engine jerking	Clogged fuel pipes	Contact REHLKO authorised workshops
Engine overheats	Insufficient coolant level	Fill up to the level
	High oil sump level	Replace the engine oil; if the problem persists, Contact REHLKO authorised workshops
	Clogged radiator	Clean the radiator; if the problem persists, contact REHLKO authorised workshops

In the event that the solutions proposed in **Tab. 7.2** do not eliminate the trouble, contact a **REHLKO** authorized workshop

8 INFORMATION ABOUT WARRANTY

8.1 *Warranty terms*

REHLKO DIESEL ENGINES GLOBAL WARRANTY TERMS

Consult the web page <https://www.engines.rehko.com/warranty> and select **Diesel Engines**

9 GLOSSARY

9.1 Glossary

A

Alternator:	A component that transforms mechanical energy into AC electrical energy.
Authorised workshop:	REHLKO authorised service centre.
ATS:	After Treatment System - Post-treatment system, referred to the exhaust gases produced by the engine.

B

Bore:	Internal diameter of the cylinder in combustion engines.
-------	--

C

Catalyst:	A device in charge of filtering exhausted gas.
Combustion:	Chemical reaction of a mixture composed of fuel and fuel (air) inside a combustion chamber.
Common Rail:	A high-pressure "Common Duct" that produces a constant supply of fuel directly to the injectors.

D

DCU:	Dosing Control Unit - It is a control unit that checks the SCR system adjusting the DEF dosage inside the SCR catalytic converter according to the parameters detected by the different sensors.
DEF:	"Diesel Exhaust Fluid"
DOC:	Diesel Oxidation Catalyst - Catalyst for diesel engines that reduces harmful exhaust gas emissions produced by the engine.
DPF:	Diesel Particulate Filter - A filter that captures particles of carbonaceous origin emitted by diesel engines.

E

EC:	"European Community".
ECS:	"Emission Control System"
ECU:	"Electronic Control Unit"; an electronic device in charge of electronically detecting and controlling other electronic control devices.

Electronic injector:	An electronically activated component able to inject jets of atomised fuel inside the cylinders.
EPA:	"Environmental Protection Agency - The United States' authority that safeguards the environment" ; its duty is to govern and control polluting emissions.
ETB:	Electronic Throttle Body - This is controlled by the ECU upon request of the accelerator pedal, and its function is crucial for the correct regeneration of the ATS system.

G

Galvanised:	Material that has undergone surface protection treatment.
-------------	---

H

Heavy conditions:	Type of extreme condition referred to the work environment in which the engine is used (very dusty - dirty area, or in a contaminated environment due to various types of gas).
-------------------	---

I

Intercooler:	Air-cooling element under pressure from the turbo situated between the turbine and intake manifold.
--------------	---

M

Maintenance - periodic:	A group of maintenance actions that have the sole objective to control and replace elements on their expiry, without modifying or improving the functions carried out by the system, neither increasing the value nor improving performance.
MAX:	"Maximum".
Methyl ester:	It is a mixture of products by means of a chemical conversion of oils and animal and/or vegetable fat, which is used to produce Biofuel.
MIN:	"Minimum"
Min.:	"Minutes".
Model:	"Model", engine identification plate, which indicates the engine's model.

O

Oil Cooler:	Small radiator used to cool the oil.
-------------	--------------------------------------

P

Par.:	Paragraph.
Paraffin:	Fatty and solid substance that may form inside the diesel.

Poly-V:	"Poly-V", the name associated with a service belt, which derives from the profile of its section that is constructed with joined Vs.
---------	--

R

Ref.:	Reference.
-------	------------

S

SCR:	Selective Catalytic Reduction
s/n:	"Serial number" (engine identification name plate) indicating the engine identification series/chassis number.
Spec.:	"Specification", (engine identification name plate) indicating the engine version.

T

Tab.:	Table.
T-MAP:	"T-MAP" (sensor), measures the temperature and absolute pressure inside the intake collector.
TCR:	"Turbo Common Rail".
Tightening torque:	A term indicated for installation of threaded components and which is determined by means of a unit of measurement Nm.
Turbocharger:	Device that compresses air intake by sending it to the intake manifold by means of a turbine.

U

Used oil:	Oil altered by operation or time, which is no longer compliant for correct lubrication of the components.
-----------	---

W

Waste-Gate valve:	A device, which is directly or automatically controlled, used to limit the pressure of exhaust gas inside the turbine.
-------------------	--

SYMBOLS AND UNITS OF MEASUREMENT			
SYMBOL	UNIT OF MEASUREMENT	DESCRIPTION	EXAMPLE
α	degree	Rotation/inclination angle	1°
cm ²	square centimetre	Area	1 cm ²
Ø	millimetre	Circumference	Ø 1 mm
Nm	newton-metre	Torque	1 Nm
mm	millimetre	Length	1 mm
µm	1/1000 of a millimetre (micron)		1 µm
H	hour		Time
g/kW	grammes per kilowatt per hour	Specific consumption	1 g/kWh
kg/h	kilogramme per hour	Max. flow rate	1 kg/h
Lt./min.	litres per minute	Flow rate	1 Lt./min.
Lt./h	litres per hour		1 Lt./h
ppm	parts per million	Percentage	1 ppm
N	newton	Force	1 N
A	Ampere	Intensity of electrical current	1 A
gr.	gramme	Weight	1 gr.
kg	kilogramme		1 kg
W	Watt	Power	1 W.
kW	kiloWatt		1 kW
pa	pascal	Pressure	1 pa
KPa	Kilopascal		1 KPa
bar	barometric pressure		1 bar
mbar (1/1000 bar)	barometric pressure		1 mbar
R	Resistance	Resistance to electrical current (referred to a component)	1 Ω
Ω	ohm	Resistance of electrical current	1 Ω
Rpm	revs per minute	Rotation of an axis	1 Rpm
Ra	average roughness expressed in microns	Roughness	1 Ra
°C	degree centigrade	Temperature	1°C
V	Volt	Electrical voltage	1 V
●	millimetre	Hex-head capscrew	● 1 mm
cm ³	cubic centimetre	Volume	1 cm ³
Lt.	litre		1 Lt.



Contacts: <https://www.engines.rehiko.com/contact>

Parts Catalogue: [Global Parts Lookup](#)